

# Pistol Grip Air Screwdrivers

Adjustable Cushion Clutch

## 20 & 50 Series



*Legendary performance in a compact, lightweight package with a well-deserved reputation for durability.*

### Features

- Torque Range: 4 – 100 in-lbs (0.5 – 11.3 Nm)
- Speeds: 800 – 2,600 rpm
- Skinsulate housing provides comfortable grip surface
- One-handed reverse lever
- Recommended for applications that require a torque limiting clutch

### Service and Accessories

#### Manuals:

	49999035	20 Series
	49999093	50 Series

#### Accessories (20 Series and 50 Series):

Torque arm: QTA010  
 Spring balancer, see page 177  
 Spindle accessories, see page 183  
 Suspension bail (20 Series): 47795  
 Suspension bail (50 Series): 46472

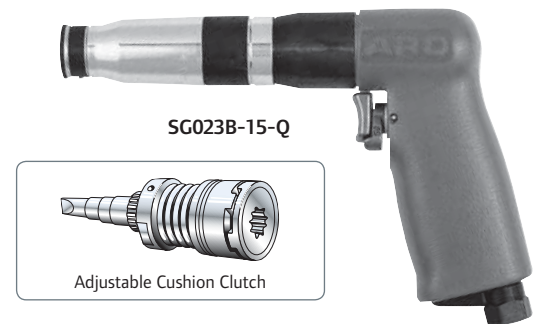



















SG023B-15-Q

Adjustable Cushion Clutch

#### Kits:

Service kit (20 Series): 46992  
 Service kit (50 Series): 47353

Model	 in-lbs (Nm)	 in-lbs (Nm)	 in-lbs (Nm)	 rpm	 lbs (kg)	 in (mm)	 in (mm)	 in	 cfm (L/min)
<b>20 SERIES TRIGGER START</b>									
SG023B-26-Q	4.0 – 12 (0.5 – 1.4)	–	–	2,600	1.7 (0.8)	6.6" (169)	0.7" (17)	1/4" 	15 (420)
SG023B-15-Q	4.0 – 20 (0.5 – 2.3)	–	–	1,500	1.8 (0.8)	7.0" (178)	0.7" (17)	1/4" 	15 (420)
SG023B-9-Q	4.0 – 20 (0.5 – 2.3)	20 – 30 (2.3 – 3.4)	–	900	1.8 (0.8)	7.0" (178)	0.7" (17)	1/4" 	15 (420)
<b>50 SERIES TRIGGER START</b>									
SG053B-25-Q	10 – 40 (1.1 – 4.5)	–	–	2,500	2.9 (1.4)	8.9" (226)	0.8" (21)	1/4" 	25 (720)
SG053B-17-Q	10 – 40 (1.1 – 4.5)	15 – 60 (1.7 – 6.8)	–	1,700	3.1 (1.5)	9.4" (238)	0.8" (21)	1/4" 	25 (720)
SG053B-10-Q	10 – 40 (1.1 – 4.5)	15 – 80 (1.7 – 9.0)	–	1,000	3.1 (1.5)	9.4" (238)	0.8" (21)	1/4" 	25 (720)
SG053B-8-Q	10 – 40 (1.1 – 4.5)	15 – 80 (1.7 – 9.0)	45 – 100 (5.1 – 11.3)	800	3.1 (1.5)	9.4" (238)	0.8" (21)	1/4" 	25 (720)

Series			
20	76 dBa	1/4" NPT	5/16" (8 mm)
50	78 dBa	1/4" NPT	5/16" (8 mm)

# Inline Air Screwdrivers

## Adjustable Cushion Clutch

### 20 & 50 Series

Legendary performance in a compact, lightweight package with a well-deserved reputation for durability.

#### Features

- Torque range: 4 – 100 in-lbs (0.5 – 11.3 Nm)
- Speeds: 800 – 2,600 rpm
- Skinsulate housing provides comfortable grip surface
- Simple push-button reverse
- Recommended for assembling that requires a torque limiting clutch

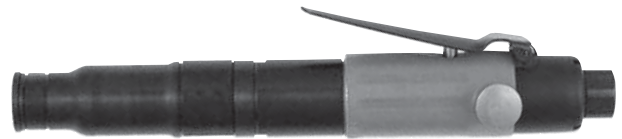

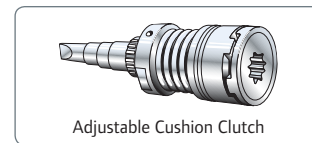

SL023B-15-Q



Adjustable Cushion Clutch

#### Service and Accessories

##### Manuals:















-  49999035 20 Series
-  49999093 50 Series

##### Accessories:

- Torque reaction arm: QTA010  
Spring balancer, see page 177  
Spindle accessories, see page 183  
Piped away exhaust kit: 5L-K184

##### Kits:

- 20 Series tune-up kit: 46992  
50 Series tune-up kit: 47353

Model	in-lbs (Nm)	in-lbs (Nm)	in-lbs (Nm)	rpm	lbs (kg)	in (mm)	in (mm)	in	cfm (L/min)
<b>20 SERIES LEVER START</b>									
SL023B-26-Q	-	4.0 – 12 (0.5 – 1.4)	-	2,600	1.2 (0.5)	8.2" (208)	0.6" (15)	1/4" 	15 (420)
SL023B-15-Q	-	4.0 – 20 (0.5 – 2.3)	-	1,500	1.3 (0.6)	8.5" (217)	0.6" (15)	1/4" 	15 (420)
SL023B-9-Q	-	4.0 – 20 (0.5 – 2.3)	20 – 30 (2.3 – 3.4)	900	1.3 (0.6)	8.5" (217)	0.6" (15)	1/4" 	15 (420)
<b>20 SERIES PUSH-TO-START</b>									
SA023B-26-Q	-	4.0 – 12 (0.5 – 1.4)	-	2,600	1.2 (0.5)	8.2" (208)	0.6" (15)	1/4" 	15 (420)
SA023B-15-Q	-	4.0 – 20 (0.5 – 2.3)	-	1,500	1.3 (0.6)	8.5" (217)	0.6" (15)	1/4" 	15 (420)
SA023B-9-Q	-	4.0 – 20 (0.5 – 2.3)	20 – 30 (2.3 – 3.4)	900	1.3 (0.6)	8.5" (217)	0.6" (15)	1/4" 	15 (420)
<b>50 SERIES LEVER START</b>									
SL053B-25-Q	10 – 40 (1.1 – 4.5)	-	-	2,500	2.9 (1.4)	10.4" (264)	0.8" (21)	1/4" 	25 (720)
SL053B-17-Q	10 – 40 (1.1 – 4.5)	15 – 60 (1.7 – 6.8)	-	1,700	3.1 (1.5)	10.9" (277)	0.8" (21)	1/4" 	25 (720)
SL053B-10-Q	10 – 40 (1.1 – 4.5)	15 – 80 (1.7 – 9.0)	-	1,000	3.1 (1.5)	10.9" (277)	0.8" (21)	1/4" 	25 (720)
SL053B-8-Q	10 – 40 (1.1 – 4.5)	15 – 80 (1.7 – 9.0)	45 – 100 (5.1 – 11.3)	800	3.1 (1.5)	10.9" (277)	0.8" (21)	1/4" 	25 (720)
<b>50 SERIES PUSH-TO-START</b>									
SA053B-25-Q	10 – 40 (1.1 – 4.5)	-	-	2,500	2.6 (1.2)	10.4" (264)	0.8" (21)	1/4" 	25 (720)
SA053B-17-Q	10 – 40 (1.1 – 4.5)	15 – 60 (1.7 – 6.8)	-	1,700	2.8 (1.3)	10.9" (277)	0.8" (21)	1/4" 	25 (720)
SA053B-10-Q	10 – 40 (1.1 – 4.5)	15 – 80 (1.7 – 9.0)	-	1,000	2.8 (1.3)	10.9" (277)	0.8" (21)	1/4" 	25 (720)
SA053B-8-Q	10 – 40 (1.1 – 4.5)	15 – 80 (1.7 – 9.0)	45 – 100 (5.1 – 11.3)	800	2.8 (1.3)	10.9" (277)	0.8" (21)	1/4" 	25 (720)

Series			
20	76 dBA	1/4" NPT	5/16" (8mm)
50	78 dBA	1/4" NPT	5/16" (8mm)

## 50 Series

Legendary performance with a well-deserved reputation for durability.

### Features

- Torque Range: 20 – 135 in-lbs (2.2 – 15.3 Nm)
- Speeds: 500 – 1,650 rpm
- Proven durability and reliability
- Multiple head and drive sizes available
- Recommended for applications requiring a torque limiting clutch

### Service and Accessories

#### Manuals:

 49999389

#### Accessories:

Spring balancer: BLD2  
Sockets, see form # IR-0506-016

#### Kits:







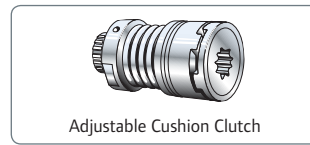









Service kit: 48804-1  
Service kit: 47407







SR053B-6H-H



Adjustable Cushion Clutch

Model	 in-lbs (Nm)	 in-lbs (Nm)	 rpm	 lbs (kg)	 in (mm)	 in (mm)	 in (mm)	 in
								
SR053B-11H-H	20 – 70 (2.2 – 7.9)	–	1,150	4.0 (1.8)	14.2" (360)	0.7" (16.5)	1.9" (48.3)	1/4" 
SR053B-11H-F	20 – 70 (2.2 – 7.9)	–	1,150	4.0 (1.8)	14.2" (360)	0.7" (16.5)	1.9" (48.3)	1/4" 
SR053B-8H-H	25 – 100 (2.8 – 11.3)	–	800	4.0 (1.8)	14.2" (360)	0.7" (16.5)	1.9" (48.3)	1/4" 
SR053B-6H-H	25 – 100 (2.8 – 11.3)	40 – 135 (4.5 – 15.3)	500	4.0 (1.8)	14.2" (360)	0.7" (16.5)	1.9" (48.3)	1/4" 
NR053B-16R-1	25 – 58 (2.8 – 6.5)	–	1,650	3.6 (1.6)	13.5" (343)	0.6" (15.0)	1.5" (38.1)	1/4" 
NR053B-11H-2	20 – 70 (2.2 – 7.9)	–	1,150	4.0 (1.8)	14.2" (360)	0.7" (16.5)	1.9" (48.3)	3/8" 
NR053B-8H-2	25 – 100 (2.8 – 11.3)	–	800	4.0 (1.8)	14.2" (360)	0.7" (16.5)	1.9" (48.3)	3/8" 
NR053B-6H-2	25 – 100 (2.8 – 11.3)	40 – 135 (4.5 – 15.3)	500	4.0 (1.8)	14.2" (360)	0.7" (16.5)	1.9" (48.3)	3/8" 

Series				
50	80 dBA	1/4" NPT	5/16" (8 mm)	25 cfm (720 L/min)