

## 20 Series

Legendary performance in a compact, lightweight package.

### Features

- Torque range: 3.0 – 40 in-lbs (0.34 – 4.5 Nm)
- Speeds: 800 – 2,600 rpm
- Skinsulate housing provides comfortable grip surface
- One-handed reverse lever
- Recommended for applications where precise torque control is required

### Service and Accessories

#### Manuals:

 49999246









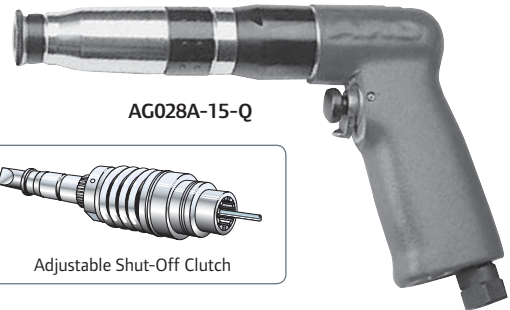









#### Accessories:

Torque arm: QTA010  
 Suspension bail: 48934  
 Spring balancer: BLD1  
 Spindle accessories, see page 183

#### Kits:

Tune-up kit: 48846



Model	 in-lbs (Nm)	 in-lbs (Nm)	 in-lbs (Nm)	 rpm	 lbs (kg)	 in (mm)	 in (mm)	 in	 cfm (L/min)
<b>TRIGGER START</b>									
AG027A-15-Q	3.0 – 10 (0.34 – 1.1)	8.0 – 20 (0.9 – 2.3)	-	1,500	1.9 (0.9)	8.3" (210)	0.7" (17)	1/4" 	15 (420)
AG027A-9-Q	3.0 – 10 (0.34 – 1.1)	8.0 – 20 (0.9 – 2.3)	10 – 30 (1.1 – 3.4)	900	1.9 (0.9)	8.3" (210)	0.7" (17)	1/4" 	15 (420)
AG027A-8-Q	4.0 – 13 (0.5 – 1.5)	10 – 26 (1.1 – 2.9)	12 – 40 (1.4 – 4.5)	800	1.9 (0.9)	8.3" (210)	0.7" (17)	1/4" 	15 (420)
<b>PUSH-TO-START</b>									
AG024A-15-Q	3.0 – 10 (0.34 – 1.1)	8.0 – 20 (0.9 – 2.3)	-	1,500	1.9 (0.9)	8.3" (210)	0.7" (17)	1/4" 	15 (420)
AG024A-9-Q	3.0 – 10 (0.34 – 1.1)	8.0 – 20 (0.9 – 2.3)	10 – 30 (1.1 – 3.4)	900	1.9 (0.9)	8.3" (210)	0.7" (17)	1/4" 	15 (420)
AG024A-8-Q	4.0 – 13 (0.5 – 1.5)	10 – 26 (1.1 – 2.9)	12 – 40 (1.4 – 4.5)	800	1.9 (0.9)	8.3" (210)	0.7" (17)	1/4" 	15 (420)
<b>TRIGGER + PUSH-TO-START</b>									
AG028A-26-Q	3.0 – 10 (0.34 – 1.1)	-	-	2,600	1.8 (0.8)	7.9" (200)	0.7" (17)	1/4" 	15 (420)
AG028A-15-Q	3.0 – 10 (0.34 – 1.1)	8.0 – 20 (0.9 – 2.3)	-	1,500	1.9 (0.9)	8.3" (210)	0.7" (17)	1/4" 	15 (420)
AG028A-9-Q	3.0 – 10 (0.34 – 1.1)	8.0 – 20 (0.9 – 2.3)	10 – 30 (1.1 – 3.4)	900	1.9 (0.9)	8.3" (210)	0.7" (17)	1/4" 	15 (420)
AG028A-8-Q	4.0 – 13 (0.5 – 1.5)	10 – 26 (1.1 – 2.9)	12 – 40 (1.4 – 4.5)	800	1.9 (0.9)	8.3" (210)	0.7" (17)	1/4" 	15 (420)

Series			
20	76 dBa	1/4 NPT	5/16" (8 mm)

# Inline Air Screwdrivers

## Adjustable Shut-Off Clutch

### 20 & 50 Series



Legendary performance in a compact, lightweight package with a well-deserved reputation for durability.

#### Features

- Torque range: 3.0 – 100 in-lbs (0.34 – 11.3 Nm)
- Speeds: 800 – 2,600 rpm
- Skinsulate housing provides comfortable grip surface on push-to-start models
- Simple push-button reverse
- Recommended for joints where precise torque control is required

#### Service and Accessories

##### Manuals:

-  49999035 20 Series
-  49999246
-  49999093 50 Series

##### Accessories:







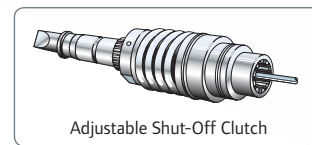





- Torque arm: QTA010
- Spring balancer, see page 177
- Spindle accessories, see page 183
- Workstation, see page 182
- Dead handle: 48931 (50 Series only)
- Piped away exhaust kit: 5L-K184



AS028A-15-Q



Adjustable Shut-Off Clutch

Model	in-lbs (Nm)	in-lbs (Nm)	in-lbs (Nm)	rpm	lbs (kg)	in (mm)	in (mm)	in	cfm (L/min)
<b>20 SERIES PUSH-TO-START</b>									
SA024C-26-Q	3.0 – 10 (0.34 – 1.1)	–	–	2,600	1.2 (0.5)	8.3" (210)	0.6" (15)	1/4" 	15 (420)
SA024C-15-Q	3.0 – 10 (0.34 – 1.1)	8.0 – 20 (0.9 – 2.3)	–	1,500	1.3 (0.6)	8.6" (219)	0.6" (15)	1/4" 	15 (420)
SA024C-9-Q	3.0 – 10 (0.34 – 1.1)	8.0 – 20 (0.9 – 2.3)	10 – 30 (1.1 – 3.4)	900	1.3 (0.6)	8.6" (219)	0.6" (15)	1/4" 	15 (420)
SA024C-8-Q	4.0 – 13 (0.5 – 1.5)	10 – 26 (1.1 – 2.9)	12 – 40 (1.4 – 4.5)	800	1.3 (0.6)	8.6" (219)	0.6" (15)	1/4" 	15 (420)
<b>20 SERIES LEVER + PUSH-TO-START</b>									
AS028A-15-Q	3.0 – 10 (0.34 – 1.1)	8.0 – 20 (0.9 – 2.3)	–	1,500	1.5 (0.7)	9.5" (240)	0.6" (15)	1/4" 	15 (420)
AS028A-9-Q	3.0 – 10 (0.34 – 1.1)	8.0 – 20 (0.9 – 2.3)	10 – 30 (1.1 – 3.4)	900	1.5 (0.7)	9.5" (240)	0.6" (15)	1/4" 	15 (420)
AS028A-8-Q	4.0 – 13 (0.5 – 1.5)	10 – 26 (1.1 – 2.9)	12 – 40 (1.4 – 4.5)	800	1.5 (0.7)	9.5" (240)	0.6" (15)	1/4" 	15 (420)
<b>50 SERIES PUSH-TO-START</b>									
SA054C-17-Q	15 – 40 (1.7 – 4.5)	25 – 60 (2.8 – 6.8)	–	1,700	2.8 (1.3)	10.3" (260)	0.9" (22)	1/4" 	25 (720)
SA054C-10-Q	15 – 40 (1.7 – 4.5)	25 – 60 (2.8 – 6.8)	35 – 80 (4.0 – 9.0)	1,000	2.8 (1.3)	10.3" (260)	0.9" (22)	1/4" 	25 (720)
SA054C-8-Q	15 – 40 (1.7 – 4.5)	25 – 60 (2.8 – 6.8)	35 – 100 (4.0 – 11.3)	800	2.8 (1.3)	10.3" (260)	0.9" (22)	1/4" 	25 (720)
<b>50 SERIES LEVER + PUSH-TO-START</b>									
AS058A-10-Q	15 – 40 (1.7 – 4.5)	25 – 60 (2.8 – 6.8)	35 – 80 (4.0 – 9.0)	1,000	3.0 (1.4)	10.9" (278)	0.9" (22)	1/4" 	25 (720)
AS058A-8-Q	15 – 40 (1.7 – 4.5)	25 – 60 (2.8 – 6.8)	35 – 100 (4.0 – 11.3)	800	3.0 (1.4)	10.9" (278)	0.9" (22)	1/4" 	25 (720)

Series			
20	76 dBA	1/4" NPT	5/16" (8mm)
50	80 dBA	1/4" NPT	5/16" (8mm)