

Marxal Marking Pen Peening & Scaling Hammer

Special Purpose Tools

MARXAL™ Marking Pen

- Comfortable, easy-to-use tool for marking products or tooling for identification.
- A popular tool for marking welds for identification.
- Can be used to scribe a line on glass for cutting.
- Choice of fine, medium or coarse marking point.

Standard Equipment

- Medium Point
- 6' X 1/8" (1.8m X 3.2mm) Air Hose



8315

Marxal Marking Pen

Model No.	Throttle Type	Strokes per Minute	Standard Point Type	Exhaust Location	Tool Length in. mm	Tool Weight lbs kg	Air Consup. @ Free Speed cfm L/s	Standard Point Part No.
8315	Twist	36,000	Medium	Front	6.4 163	4.8 .13	1.5 .7	39862-2

- Most Popular Model Hose Inlet – 1/4" NPTM Recommended Air Pressure – 90 PSI (6.2 bar)

No Cost Options (Order "with" Options)

For Models	Part No.	Description	Substituted for Standard
8315	39862-1	Fine point	Medium point
8315	39862-3	Coarse point	Medium point

Peening and Scaling Hammer

Furnished complete as illustrated with:

- 1/4" female N.P.F.T air inlet
- Alloy-Steel hammer tip

Peening and Scaling Hammer

Model No.	Throttle Type	Blows per Min.	Head Height	Tool Weight
7002	Button	5,000	2 1/2"	10 1/2 oz

Recommended Hose Size – 5/16"



7002

Laminate Trimmer

20,000 rpm /0.5 hp (.34 kW)

- Excellent tool for fast, accurate trimming of plastic laminates.
- May be operated in either the vertical or horizontal plane.

Standard Equipment

- Collet
- Collet Wrenches

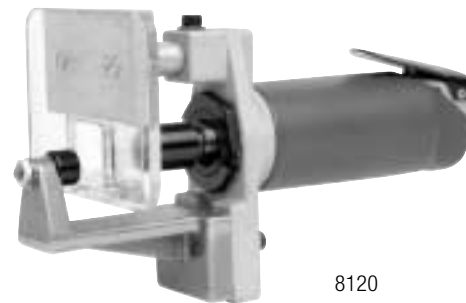

8120

Laminate Trimmer

Model No.	Free Speed rpm	Throttle Style	Standard Collet Size in. mm	Exhaust Location	Tool Height in. mm	Tool Width in. mm	Tool Weight lbs kg	Air Consup @ Free Speed cfm L/s	Sound Level @ Free Speed dBA	Standard Collet Part No.
8120	20,000	Lever	1/4 6	Front	7.8 198	2.5 64	1.9 .86	27 13	84	33226-8

- Air Inlet – 1/4" NPTF Recommended Air Pressure – 90 PSI (6.2 bar) Recommended Hose Size – 3/8" (10 mm) i.D.

No Cost Options (Order "with" Options)

For Models	Part No.	Description	Substituted for Standard
8120	33226-()	Erickson Collet	Erickson Collet

Portable Electrode Dressers

Special Purpose Tools

The Economical Solution to Dressing Worn Electrode Tips.

Dressing Electrodes vs. New Tips

Worn electrode tips produce either poor welds or no welds at all, limiting both quality and productivity. Two possible solutions to worn tips are to (1) replace them with new, or (2) recondition existing tips on either a lathe, drill press, or with a portable ARO Electrode Dresser.

Replacing tips is a costly and time consuming alternative. Reconditioning tips on standard machine shop equipment, although providing uniformly dressed electrodes, cuts valuable production time. Reconditioning worn tips with an ARO Electrode Dresser, however, is a convenient, economical solution that minimizes downtime.



7165-B (22 Series)



8040-E (2200 Series)

Dressing Electrodes with ARO's Portable Electrode Dresser

Reconditioning with an ARO pneumatic Electrode Dresser is a quick, easy, and accurate method of dressing worn electrodes. Downtime is virtually eliminated because each electrode is automatically dressed in seconds with precision, without removing the tip from the machine.

Once dressed, the electrode has a perfectly shaped tip for producing uniform, quality welds. Furthermore, a properly shaped electrode top reduces energy consumption during the welding process and greatly extends electrode life.

ARO Portable Electrode Dressers

ARO offers two models of electrode dressers in several speed options. Both models accept a wide variety of blade and solid-type cutters to accurately dress electrodes from 5/16" to 1 1/2" diameter. They are lightweight and easy to operate, requiring no special training for the operator.

The "22" Series Electrode Dresser is the most popular model and provides adequate power to dress most electrode tips. For larger electrodes where a lot of material must be removed during the dressing operation, the "2200" Series Electrode Dresser is recommended. Three speed options are available in the "2200" Series, with the lower speeds providing more dressing power at a slower material removal rate.

To reduce production downtime, increase electrode tip life, reduce energy consumption, and maintain quality welds, recondition your worn electrode tips with an ARO Portable Electrode Dresser.

22 Series

Model No.	rpm	Electrode Capacity	Air Inlet	Recommended Hose Size	Weight
7165-B	1500	5/16" D to 1 1/2" D	1/4" NPT(F)	5/16" I.D.	3.5 lbs

Extra Cost Options: Cutter blades and adapters. Order separate. See pages 89-92.

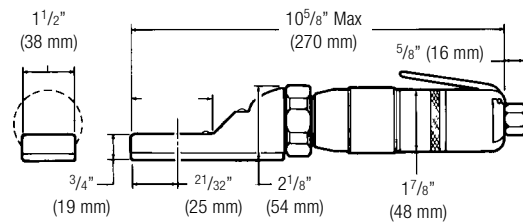

2200 Series

Model No.	rpm	Electrode Capacity	Air Inlet	Recommended Hose Size	Weight
8038-E	250	5/16" D to 1 1/2" D	1/4" NPT(F)	5/16" I.D.	5.5 lbs
8039-E	450	5/16" D to 1 1/2" D	1/4" NPT(F)	5/16" I.D.	5.5 lbs
8040-E	1000	5/16" D to 1 1/2" D	1/4" NPT(F)	5/16" I.D.	4.6 lbs

Extra Cost Options: Cutter blades and adapters. Order separate. See pages 89-92.

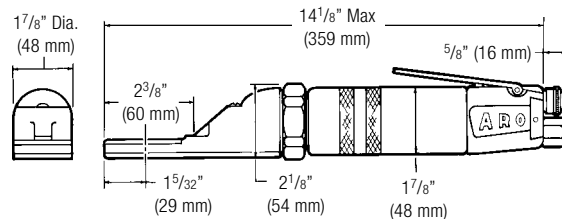

Portable Electrode Dressers

Special Purpose Tools

Solid-Type - 0.3625 Dia. (9.2 mm)

Series	Cutter
2200	40856

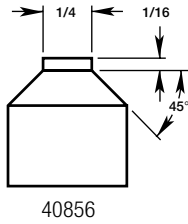

Solid-Type - 0.437 Dia. (11.1 mm)

Series	Cutter
2200	40856

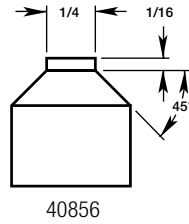

Solid-Type - 0.460 Dia. (11.7 mm)

Series	Cutter
2200	40856

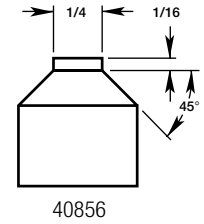

Solid-Type - 0.482 Dia. (12.2 mm)

Series	Cutter	Adapter	Cutter	Adapter	Cutter	Adapter	Cutter
22	32530	-	32529	-	32528	-	-
2200	32530	38083	32529	38083	32528	38083	40856

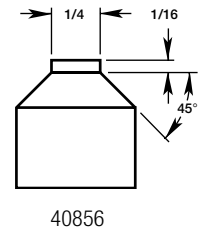
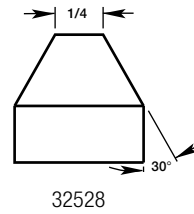
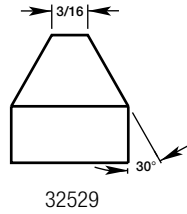
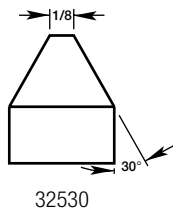

Blade-Type - 0.482 Dia. (12.2 mm)

Series	Cutter	Adapter	Cutter	Holder	Adapter
22	32509	-	32452	38409	-
2200	32509	38083	32452	38409	38083

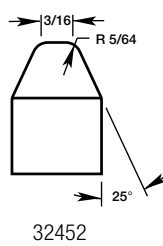
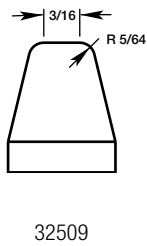

Blade-Type - 0.482 Dia. (12.2 mm)

Series	Cutter	Adapter
22	38406	-
2200	38406	38083

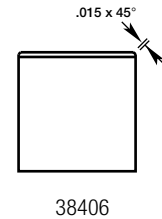

Solid-Type - 0.490 Dia. (12.4 mm)

Series	Cutter	Adapter	Cutter
22	32528	-	-
2200	32528	38083	40856

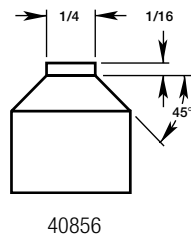
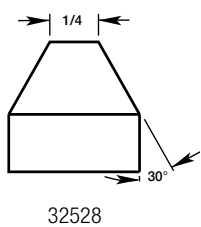

Portable Electro Dressers

Special Purpose Tools

Solid-Type - 0.500 Dia. (12.7 mm)

Series	Cutter	Adapter	Cutter	Adapter	Cutter	Adapter	Cutter
22	32530	-	32529	-	32528	-	-
2200	32530	38083	32529	38083	32528	38083	40856

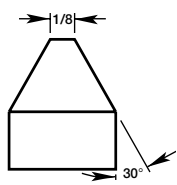

32530

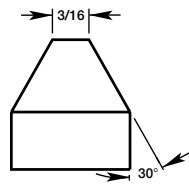

32529

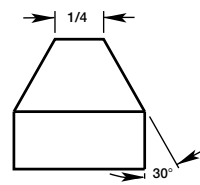

32528

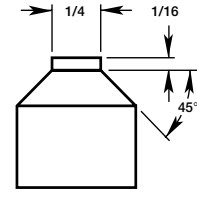

40856

Blade-Type - 0.500 Dia. (12.7 mm)

Series	Cutter	Holder	Adapter
22	32283	32288	-
2200	32283	32288	38083

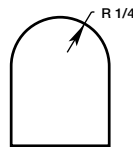

32283

Solid-Type - 0.588 Dia. (14.9 mm)

Series	Cutter
2200	40856

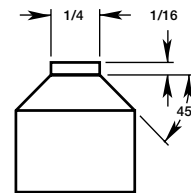

40856

Solid-Type - 0.625 Dia. (15.9 mm)

Series	Cutter	Adapter	Cutter	Adapter	Cutter	Adapter
22	40278	-	32530	-	32528	-
2200	40278	38083	32530	38083	32528	38083

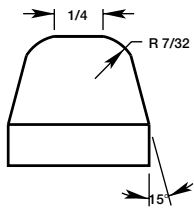

40278

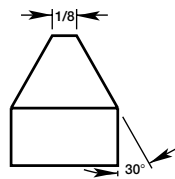

32530

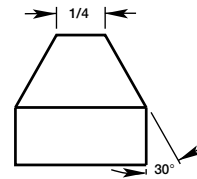

32528

Solid-Type - 0.625 Dia. (15.9 mm) Continued

Series	Cutter	Cutter	Cutter	Cutter	Cutter
2200	38417-1	38417-2	40856	38419-2	38171

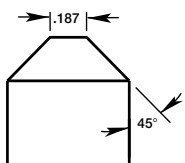

38417-1

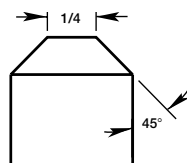

38417-2

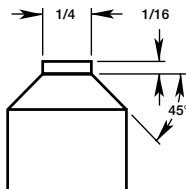

40856

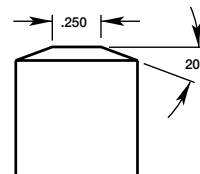

38419-2

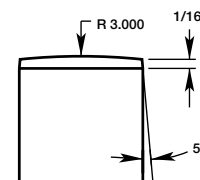

38171

Portable Electrode Dressers
Special Purpose Tools

Blade-Type - 0.625 Dia. (15.9 mm)

Series	Cutter	Holder	Adapter	Cutter	Holder	Adapter	Cutter	Holder	Adapter
22	32284	32282-2	-	32455	32282-2	-	-	-	-
2200	32284	32282-2	38083	32455	32282-2	38083	32453	32282-2	38083

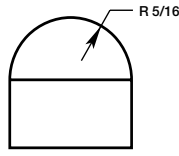

32284

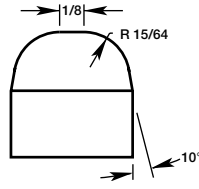

32455

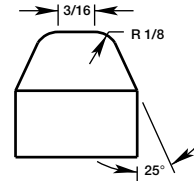

32453

Blade-Type - 0.625 Dia. (15.9 mm) Continued

Series	Cutter	Adapter	Cutter	Holder	Adapter
22	32510	-	33090	32282-2	-
2200	32510	38083	33090	32282-2	38083

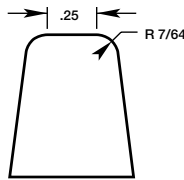

32510

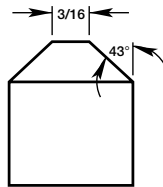

33090

Blade-Type - 0.625 Dia. (15.9 mm) Continued

Series	Cutter	Holder	Adapter	Cutter	Holder	Adapter
22	40907	32282-2	-	32491	32282-2	-
2200	40907	32282-2	38083	32491	32282-2	38083

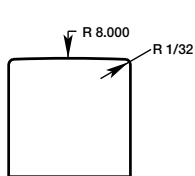

40907

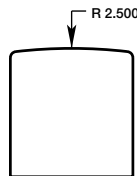

32491

Blade-Type - 0.625 Dia. (15.9 mm) Continued

Series	Cutter	Holder	Adapter
22	38408	-	-
2200	32447	32282-2	38083
2200	38408	-	38083

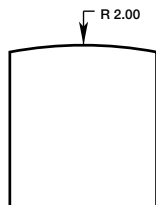

38408
32447

Portable Electrode Dressers

Special Purpose Tools

Solid-Type - 0.750 Dia. (19.1 mm)

Series	Cutter	Cutter	Cutter
2200	38418-1	40856	38418-2

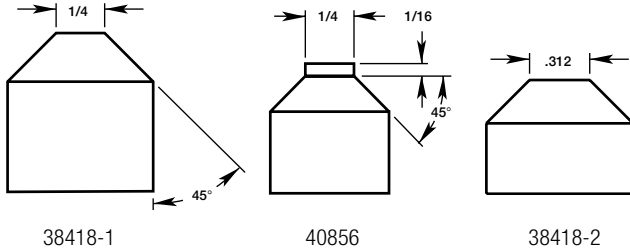

Solid-Type - 0.875 Dia. (22.2 mm)

Series	Cutter
2200	40856

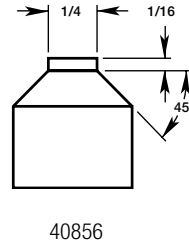

Flush-Type

For use on both "22" and "2200" Series Electrode Dressers. Requires 38083 adapter for "2200" Series tools.

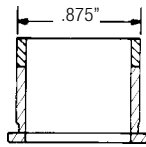

Standard-Type
Blade Holder

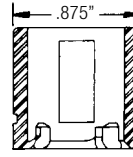

Trimmer-Type
Blade Holder

Electrode Dia.	Holder No.	Type
0.482	38409	Trimmer
0.500	32288	Standard
0.625	32282-2	Standard

Adapters

To permit "2200" Series tools, which normally drive 1.125" O.D. cutters and holders, to utilize all .875" O.D. cutters and holders.

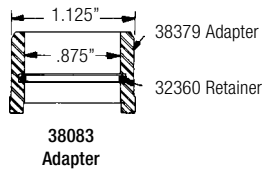

38083
Adapter

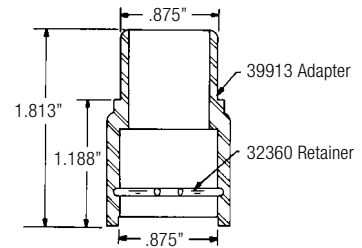

39914 Extension
Adapter

Use when a .875 O.D. holder or cutter is required in an extended position from the tool. 38083 adapter is required for use on "2200" Series tools.