

1 1/2" – 3 1/2" Class Impacttools



ft-lb (Nm)	0	2,000 (2,712)	4,000 (5,423)	6,000 (8,135)	8,000 (10,847)	10,000 (13,558)
2950B7		RECOMMENDED TORQUE RANGE				
3955A1Ti		RECOMMENDED TORQUE RANGE				
3955A2Ti		RECOMMENDED TORQUE RANGE				
3955B1Ti		RECOMMENDED TORQUE RANGE				
3955B2Ti		RECOMMENDED TORQUE RANGE				
5980A1		RECOMMENDED TORQUE RANGE				

ft-lb (Nm)	0	20,000 (27,116)	40,000 (54,233)	60,000 (81,349)	80,000 (108,446)
5982A1		RECOMMENDED TORQUE RANGE			
588A1		RECOMMENDED TORQUE RANGE			
599A1		RECOMMENDED TORQUE RANGE			

RECOMMENDED TORQUE RANGE

MAXIMUM TORQUE

1-1/2" Impacttools

2950B7

- 1/2" NPT inlet
- Plated iron hammer-case
- Twin hammer mechanism
- Pressure-feed mechanism lubrication
- Durable epoxy-coated handle/housing
- Integral muffler

3955Ti Series

- 1/2" NPT inlet
- Titanium hammer-case
- Twin hammer mechanism
- 7 Vane reverse bias motor
- Choice of 1 1/2" Square or #5 spline
- Bronze endplates
- Integrated muffler

5980A1

- 3/4" NPT inlet
- Aluminum hammer-case
- Prevision ball and cam mechanism
- Built-in lubricator
- Horizontal eyebolt
- Vertical eyebolt

Optional Equipment

- Horizontal Hanger
 - 2950: Order # 2950-K366
- Piped away exhaust kit with muffler
 - 2950: Order # 2940-K184
- Dual Grip Handle
 - 5980: Order # 5980-48



MODEL	Description	Handle	Free Speed rpm	Impacts Per Minute	Max Torque ft-lb (Nm)	Recomm. Torque Range ft-lb (Nm)	Weight Less Socket lb (kg)	Length Less Socket in (mm)	Side-to-center Distance in (mm)	Recomm. Hose Size in (mm)	cfm
SUPER DUTY											
2950B7	1-1/2" square	Grip I.T.	3,750	650	3,000 (4067)	1,600 – 2,500 (2169 – 3390)	32.63 (14.8)	14.5" (368)	2.5" (64)	3/4" (19)	70
3955A1Ti	No. 5 spline	O.T.	2,750	700	5,000 (6779)	1,600 – 3,900 (2,169-5288)	34.6 (15.7)	16.5" (419.1)	2.69" (68.33)	3/4" (19)	80
3955A2Ti	1-1/2" square	O.T.	2,750	700	5,000 (6779)	1,600 – 3,900 (2,169-5288)	34.6 (15.7)	16.5" (419.1)	2.69" (68.33)	3/4" (19)	80
3955B1Ti	No. 5 spline	I.T.	2,750	700	5,000 (6779)	1,600 – 3,900 (2,169-5288)	34.6 (15.7)	16.5" (419.1)	2.69" (68.33)	3/4" (19)	80
3955B2Ti	1-1/2" square	I.T.	2,750	700	5,000 (6779)	1,600 – 3,900 (2,169-5288)	34.6 (15.7)	16.5" (419.1)	2.69" (68.33)	3/4" (19)	80
5980A1	1-1/2" square	Lever	830	1,000	10,000 (13560)	2,300 – 5,500 (3118 – 7437)	88 (39.9)	23" (584)	3.06" (78)	1" (25)	138

2 1/2" – 3 1/2" Impacttools

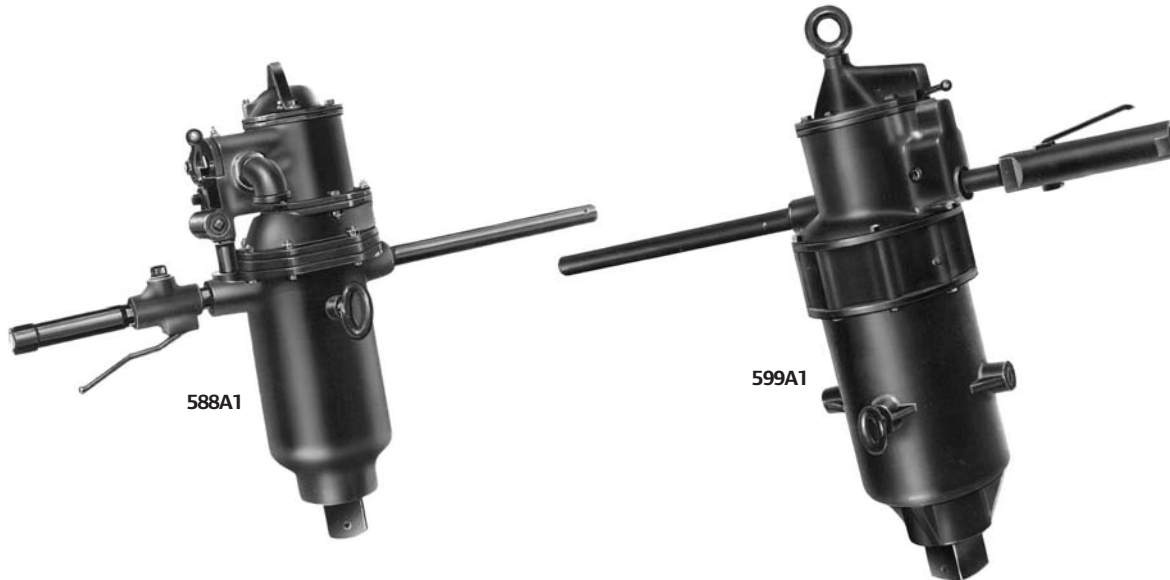

Standard Equipment

- Ball and cam mechanism
- Horizontal eyebolt
- Dead handle
- Lever throttle

5982A1

- 3/4" NPT inlet
- Aluminum hammer case
- Vertical eyebolt

588A1

- 1" NPT inlet
- Cast iron hammer-case
- Built-in lubricator
- Vertical hanger

599A1

- 1 1/4" NPT inlet
- Cast iron hammer-case
- Built-in lubricator
- Vertical eyebolt

Optional Equipment

- Horizontal Hanger
- 5982A1: Order #
ILA582A1-D366

Model	Description	Handle	Free Speed rpm	Impacts Per Minute	Max Torque ft-lb (Nm)	Recomm. Torque Range ft-lb (Nm)	Weight Less Socket lb (kg)	Length Less Socket in (mm)	Side-to-center Distance in (mm)	Recomm. Hose Size in (mm)	cfm
SUPER-DUTY											
5982A1	2-1/2" square	Lever	830	850	20,000 (27120)	4,000 – 10,000 (5424 – 13560)	120 (54.5)	25.38" (645)	3.5" (90)	1" (25)	130
588A1	2-1/2" square	Lever	355	550	50,000 (67800)	12,000 – 25,000 (16270 – 33900)	215 (97.5)	26.63" (676)	4" (101)	1" (25)	155
599A1	3-1/2" square	Lever	295	500	80,000 (108500)	26,000 – 42,000 (35250 – 57000)	599 (272)	37.5" (952)	6.75" (171)	1-1/2" (38)	375