

**PAR-A-MATIC OFFSET DRILLS
8266-A(-)-2**

TOOL WEIGHT 8.6 LBS.

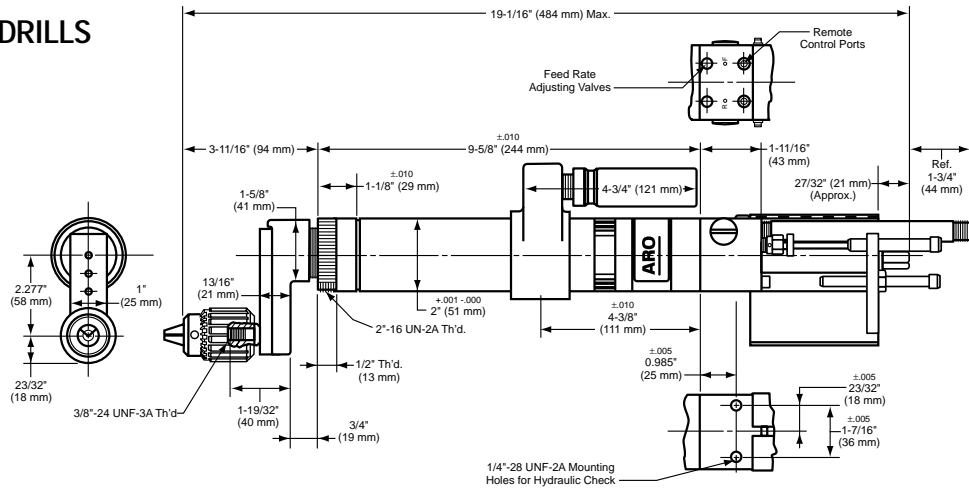

**LEAD SCREW TAPPERS
8655-B THRU 8659-B**

TOOL WEIGHT 17 LBS.

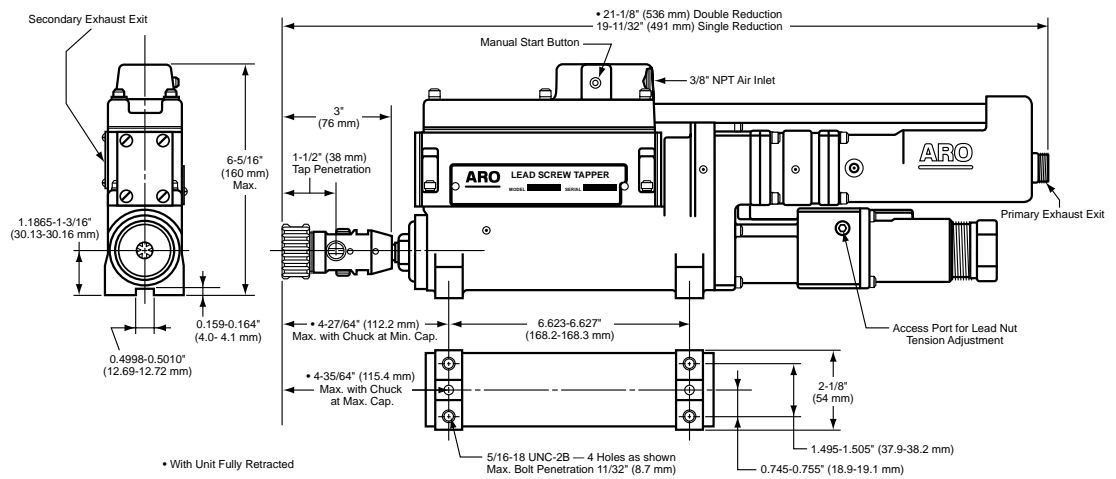

• With Unit Fully Retracted