



AW Company

LLC-BA Batch Controller



Technical Specifications:

- Nine programmable batch amounts
- Batch counter & totalizer
- 4-20 mA batch progress output
- Ability to count up or to count down
- Din panel mount enclosure
- Two relays for solenoid valve control
- Batch error compensator
- Good for small to medium sized systems

What is a LLC-BA Batch Controller?

The LLC-BA is a compact, easy to use batch controller designed as a central controller for small to medium sized fluid batching systems. Nine different batch amounts can be pre-programmed into long term memory and selected by the operator. Two relays provide control for either single or dual stage valve operation. Two totalizers are available, one acts as a batch totalizer and the other totals continuously with reset protection. The batch counter has a user selectable option to either count up from zero or count down to the batch amount. The unit's smart programming automatically compensates for variations from the selected batch amount. Inputs provide operator remote control for batch selection, start, stop and reset.



AW Company

LLC-BA Batch Controller

Controller Technical Data

Sensor Input:

Voltage triggered, 2.00 Vp-p, 0-4 Khz, 10 Kohm imp.

Enclosure:

Din# 4370016 panel mount, plastic, dust-proof, LEXAN front panel

Power Supply:

Supplied: 110 VAC wall plug unit - 12 VAC 500 mA output

Main Board:

87C51FB Microprocessor, EEPROM memory

Display:

16 Character alpha numeric LCD display
0.35 inch character height

Supply Output:

Approx. 20mA at 15 VDC

Two Form C Relay Outputs:

Relay Contact Ratings:

Maximum Switch Voltage: 220V DC, 250 VAC

Maximum Switch Current: 2A

Maximum Switched Power

Resistive Load: DC 60W / AC 125 VA

Inductive Load: DC 30W / AC 60 VA

Rated Load

Resistive Load: DC 30V, 2A / AC 110V 0.5A

Inductive Load: DC 30V, 1A / AC 110V 0.3A

Typical Batch Application

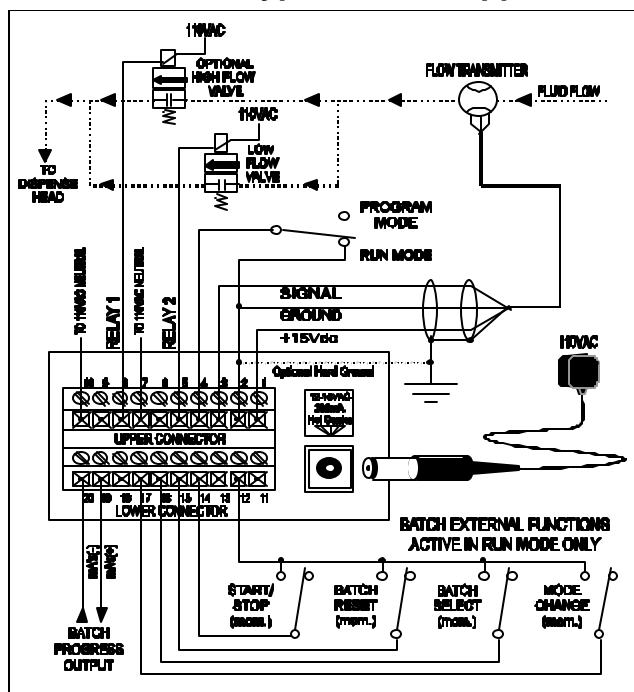

Batch Function Timing Diagram

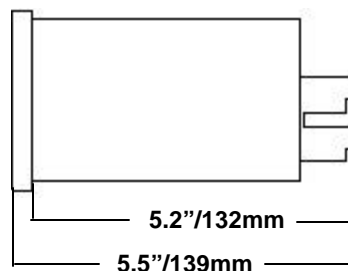
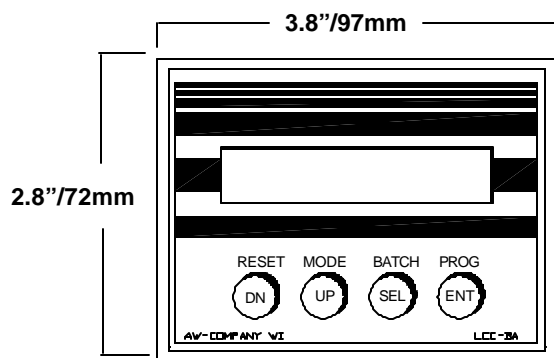
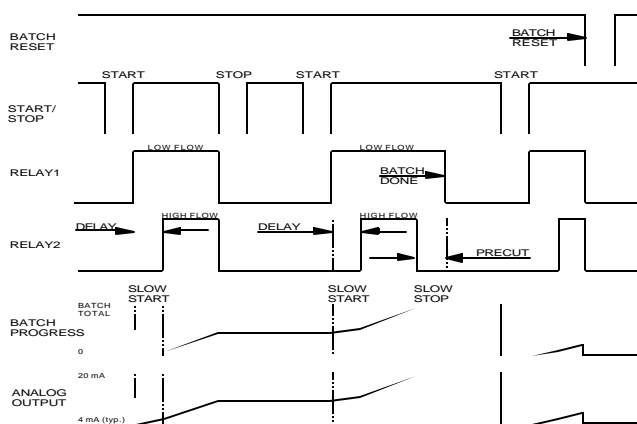

Products may be subject to change without notice - Contact factory for current information