

DOUBLE VALVE SERIES XSz With Dynamic Monitoring



OSHA    

BROCHURE 1101



Pneumatic Press Double Valves, also referred to as dual air valves or press safety valves, are used to control the air actuated systems which must always exhaust to a safe position. When used on spring loaded clutches and brakes for mechanical power presses, they function as 3/2 air valves, normally closed position. In other words, with the solenoids deenergized, this valve exhausts air from clutch/brake unit (port 2 to 3) while preventing the inlet pressure from reaching the working port. When the solenoids are energized, air pressure is supplied to the clutch/brake unit, allowing the clutch to engage.

Herion's XSz Double Valve is designed for self-checking in accordance with OSHA and ANSI. This design with its unique cross flow pattern and air logic monitor is a revolutionary technological advancement to double valve design. This design was patented by HERION.



FUNCTIONAL FEATURES

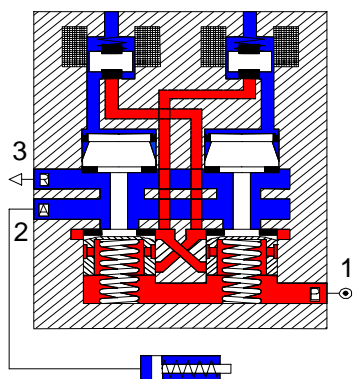

SOLENOIDS DE-ENERGIZED, VALVE CLOSED

Port "P" (1) blocked Port "A" (2) open to Port "R" (3)

Both solenoids are de-energized. Pilot valve plungers are blocking the air ducts between main valve and pilot valves. Main pistons are exhausted thru pilot valve bores. Operating port "A" is vented to atmosphere via exhaust port "R".

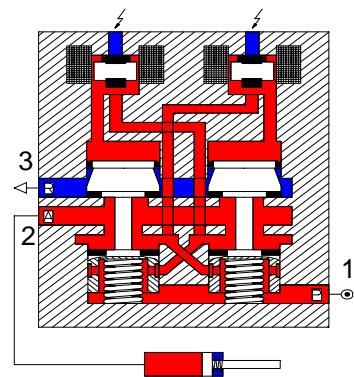

SOLENOIDS ENERGIZED, VALVE ACTUATED

Port "P" (1) open to Port "A" (2) Port "R" (3) blocked

Both solenoids are energized. Plungers shift upward to open air ducts between pilot valves and main valve. Air pressure forces both main pistons downward. Supply port "P" opens to operating port "A" and closes against exhaust port "R". Air contained in the built-in volume chambers is consumed during actuation. The chambers must refill thru their control orifices within 300 msec. to complete a successful cycle.

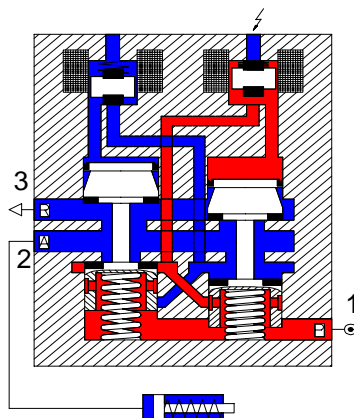





VALVE MALFUNCTION

Port "P" (1) blocked Port "A" (2) open to Port "R" (3)

Both solenoids are energized, but only the right side responds. The left pilot valve malfunctions, failing to actuate the left main piston. No pressure is supplied to operating port "A". Residual pressure at operating port "A" is vented thru exhaust port "R". The cross-flow channel remains blocked by the lower left piston assembly. The blockage prevents pressure from building in the right volume chamber within 300 msec. Further actuation of the left piston is inhibited until a new cycle is initiated.

Meets International Safety Regulations and Approvals

USA	CANADA	EUROPE	GERMANY	SWITZERLAND
OSHA				

Specifications:

Working Medium	:	Compressed air, filtered, lubricated or non-lubricated
Temperature Range	:	15° to 140° F
Operating Pressure	:	30 to 120 psig
Operating Frequency	:	165 cpm (cycles per Minute)
Body Material	:	Aluminum
Piston Seals	:	Polyurethane

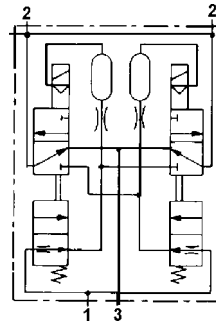

Flow Symbol

VALVE SELECTION & SPECIFICATION CHART:

Size	Type/ Model No.	NPT Port Sizes ⁽²⁾			Weight	Cv (Flow Rate)		Part No.			Valve with port 2 in back
		1 (P)	2 (A)	3 (R)		1 → 2	2 → 3	Valve/Solenoid	Voltage ⁽¹⁾	AC/DC (Hz)	
1/2	XSz-16	1/2	1/2	3/4	6 lbs.	2.8	5.8	2492920.0201	120	60 AC	2492920X02
		1/2	1/2	3/4		2.8	5.8	2492921.0201	024	DC	---
3/4	XSz-20	3/4	3/4	1	10 lbs.	8.0	13.2	2493045.0801	120	60 AC	2493045X02
		3/4	3/4	1		8.0	13.2	2493045.0801	024	DC	2493045X02
1	XSz-32	1	1	1 1/2	17 lbs.	12	23.3	2493120.0801	120	60 AC	2493120X02
		1	1	1 1/2		12	23.3	2493120.0801	024	DC	2493120X02
1 1/2	XSz-50	1 1/2	2	2	34 lbs.	20.4	62.4	2493220.0801	120	60 AC	---
		1 1/2	2	2		20.4	62.4	2493220.0801	024	DC	---

1. Additional Voltages available upon request
2. 1 (P) = Pressure port, 2 (A) = Working port, 3 (R) Exhaust Port
3. CSA certification should be requested with the purchase order

Size	Type/ Model No.	BSPP Port Sizes ^{(2) (3)}			Cv (Flow Rate)		Part No.		
		1 (P)	2 (A)	3 (R)	1 → 2	2 → 3	Valve/Solenoid	Voltage (1)	AC/DC (Hz)
1/2	XSz-16	G 1/2	G 1/2	G 3/4	2.8	5.8	2492900.0201	120	60 AC
		G 1/2	G 1/2	G 3/4	2.8	5.8	2492901.0201	024	DC
3/4	XSz-20	G 3/4	G 3/4	G 1	8.0	13.2	2493040.0801	120	60 AC
		G 3/4	G 3/4	G 1	8.0	13.2	2493040.0801	024	DC
1	XSz-32	G 1	G 1	G 1 1/2	12	23.3	2493130.0801	120	60 AC
		G 1	G 1	G 1 1/2	12	23.3	2493130.0801	024	DC
1 1/2	XSz-50	G 1 1/2	G 2	G 2	20.4	62.4	2493230.0801	120	60 AC
		G 1 1/2	G 2	G 2	20.4	62.4	2493230.0801	024	DC

1. Additional Voltages available upon request
2. 1(P) = Pressure port, 2(A) = Working port, 3 (R) = Exhaust Port
3. ISO 228/ 1 (BSPP Threads)

SOLENOIDS:

The solenoids are attached to the valve with a solenoid retaining nut and a safety washer. The coil of the solenoid is a pressure molded encapsulation. The electrical connection is made through three prongs, 2 power and 1 ground, which attach to the mating connector with one screw. Solenoids are stocked for 24 VDC and 120 VAC 60Hz. Other voltages are available on request.

Power Consumption			
Solenoid	DC	AC	
		Inrush	Holding
0201	11 W	22 VA	15 VA
0801	16 W	50 VA	27 VA

CONNECTORS:

A cable clamp type connector is included with the solenoid. Optional cable connectors are available as shown in the table.

SPECIFICATIONS: Connector conforms to ISO 4400 and the combination solenoid / connector meets classification NEMA 4. Herion solenoids are rated for 100% duty cycle and comply to insulation class F(311°)

Connector Type	Part Number		
	Standard	Lighted 24 DC	Lighted 120 VAC
Cable Clamp	0570275	0570818	0570816
Conduit 1/2	0661374	8110111	8110113
Brad Harrison 5 pin	8111900	--	--
Brad Harrison 3 pin	8110100	--	--
Cable Clamp with Surge Suppressor	8111979	--	--

SPECIAL CONNECTORS:

Another option available for those customers (i.e. automotive industry) who have standardized on 5-pin or 3-pin Brad Harrison type connectors is a pre-wired box. Customer only makes one connection instead of two. Order Part No. 8111402. For wiring details ask for brochure N-295.



ACCESSORIES

FAULT INDICATOR:

Fault indicator, which can be mounted on the press valve is used as a diagnostic device for activating a fault message. This is a single pole double throw pressure switch with adapter plate which provides an electrical signal in case of valve malfunction. Order Part No. 1028063. See Brochure N-275.



EXHAUST MUFFLERS:

Exhaust mufflers for the exhaust ports to reduce the noise. See Brochure 1081.

<u>Valve Model</u>	<u>Exhaust Port</u>	<u>Low Noise (NPT)</u>	<u>Heavy Duty ("G")</u>
XSZ-16	3/4"	0016480	0016430
XSZ-20	1"	0016580	0016530
XSZ-32	1 1/2"	0016680	0016630
XSZ-50	2"	0016780	0016730

HERION SOFT CLUTCH / BRAKE:

Large mechanical presses and large transfer presses experience noise, vibration and wear & tear due to hard engagement and hard braking. With HERION soft clutch / brake technology, pressure time curves can be fine-tuned to achieve the following:

- Controlled torque transmission
 - Noise reduction
 - Clutching / braking shock / vibration reduced
 - Less wear and tear of press drive train
- Request brochures 1250 & 717.



LOCKOUT VALVES (Brochure N-274):

As required by OSHA procedures, Herion Lockout valves are available in various sizes with yellow body and red (safety) handles. See brochure N-274.

<u>Size</u>	<u>Part No.</u>
1/2"	8111450
3/4"	8111451
1"	8111452
1 1/2"	8111970



OVERLAP CORRECTION KITS:

When separate clutch and separate brake is used on a press, delay orifices can be installed on the press valves to correct the overlap which saves the clutch from pulling the brake and vice versa. Contact Herion.

OTHER PRODUCTS FOR MECHANICAL PRESSES

- Pressure Switches** Brochure N-403
- Poppet Valves** Brochure N-223, N-223A
- FRL's** Brochure N-501

DIMENSION:

XSz-16

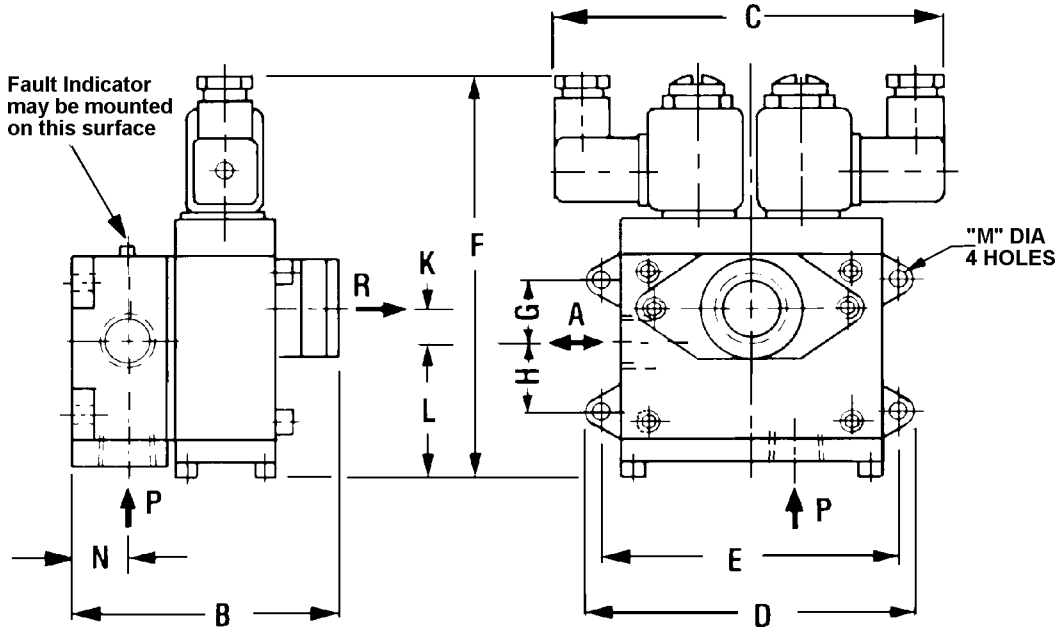

XSz-20

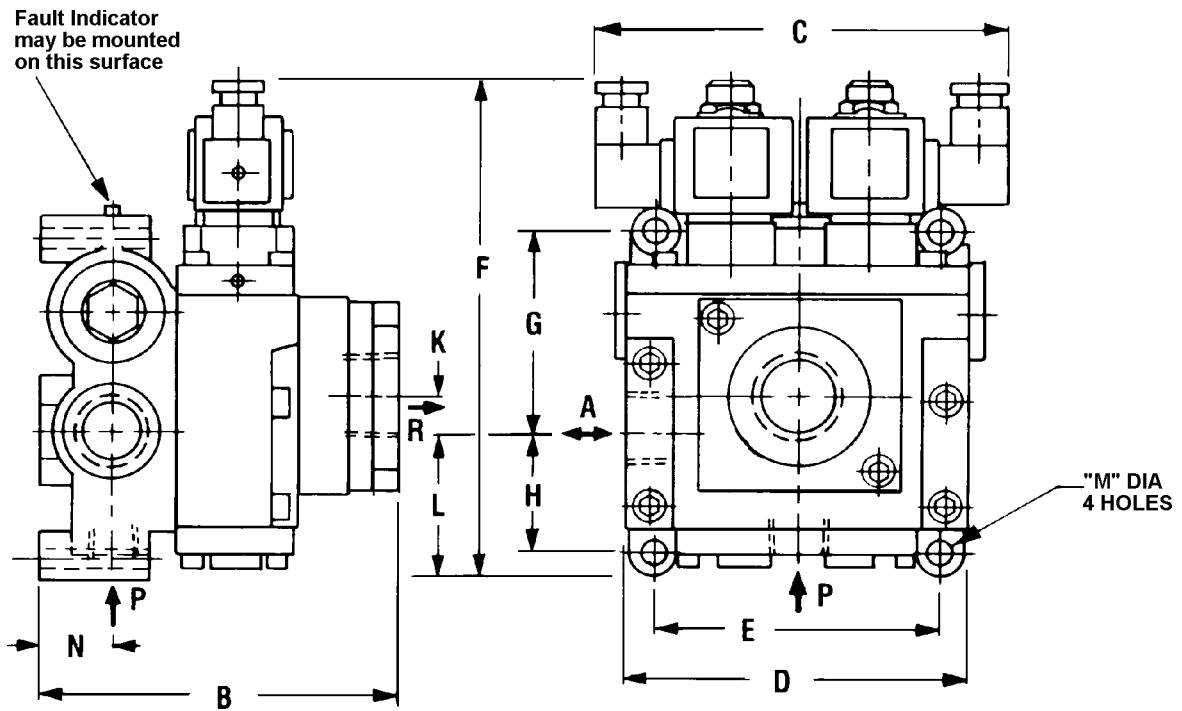

DIMENSION:

XSz-32

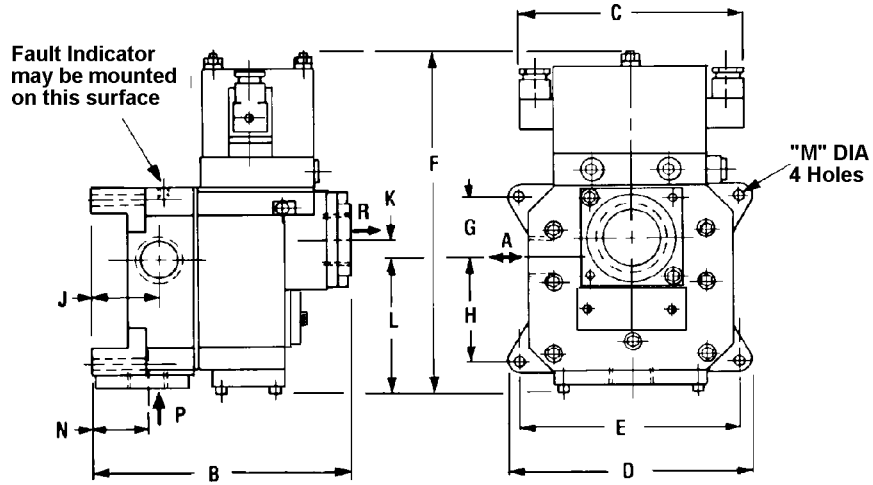

XSz-50

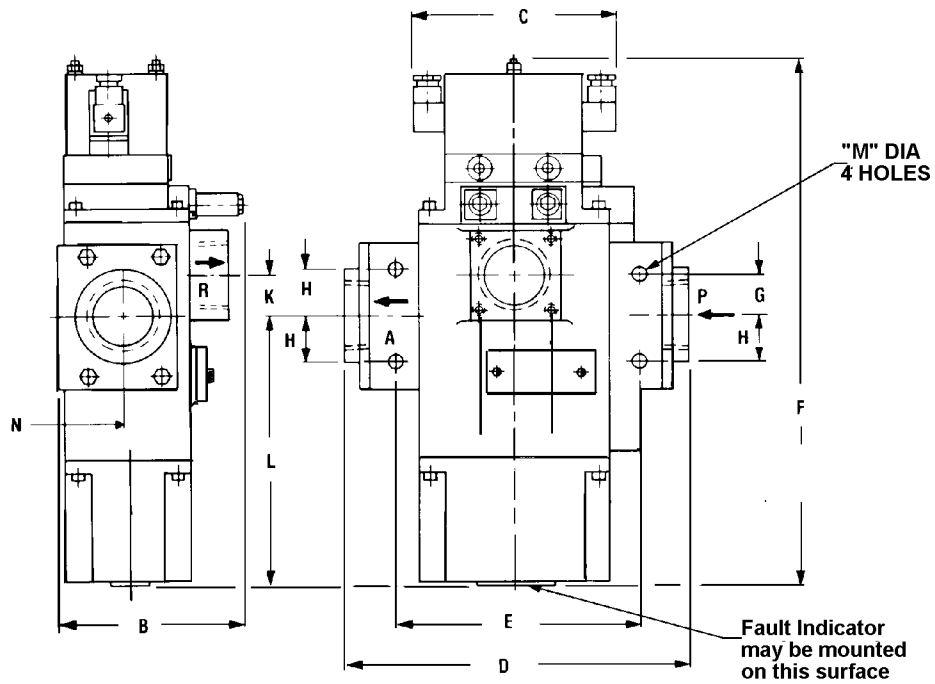

Valve	Port Sizes (NPT)			Dimensions											
	P	A	R	B	C	D	E	F	G	H	J	K	L	M	N
XSz-16	1/2	1/2	3/4	106 (4.17)	154 (6.06)	128 (5.04)	116 (4.57)	163 (6.42)	24 (.94)	29 (1.14)	--	13 (.51)	55 (2.17)	6.5 (.26)	22.5 (.89)
XSz-20	3/4	3/4	1	154 (6.06)	165 (6.50)	135 (5.31)	115 (4.53)	209 (8.23)	80 (3.15)	55 (2.17)	--	11 (.43)	65 (2.56)	8.6 (.34)	39.5 (1.56)
XSz-32	1	1	1 1/2	201 (7.91)	165 (6.50)	194 (7.64)	174 (6.85)	282 (11.10)	47 (1.85)	84 (3.3.1)	50.5 (1.99)	14 (.55)	110.5 (4.35)	11 (.43)	42.5 (1.67)
XSz-50	1 1/2	2	2	166 (6.54)	195 (7.68)	330 (12.99)	217 (8.54)	475 (18.70)	37 (1.46)	41 (1.61)	--	41 (1.61)	238 (9.37)	13 (.51)	60 (2.36)

PRESSURE BUILD-UP AND EXHAUST TIMES:

XSz-16

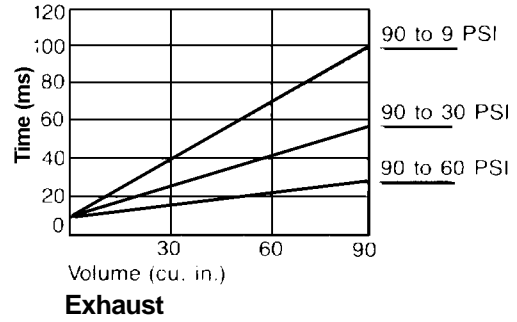
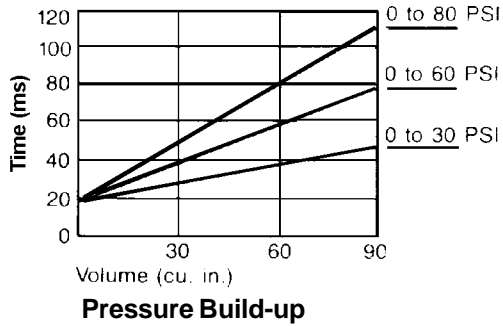

XSz-20

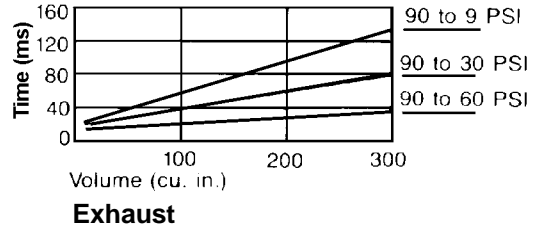
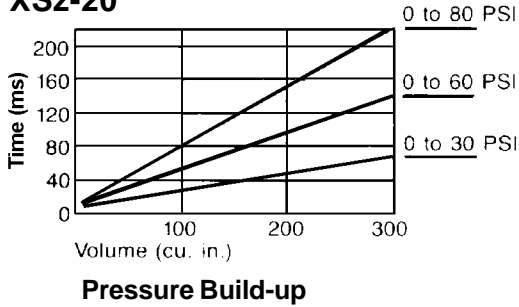

XSz-32

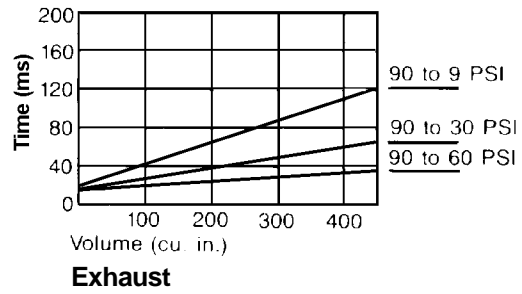
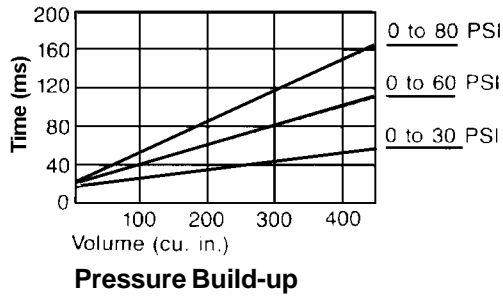

XSz-50

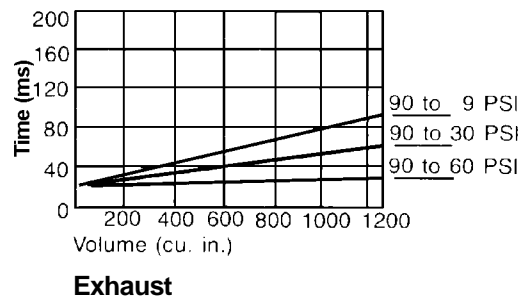
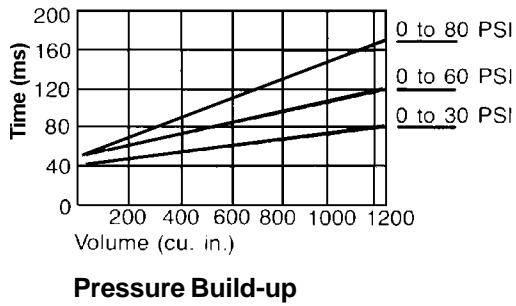

INSTALLATION:

The preferred orientation of the Double Valve is with the poppets or spindles vertical. Distance between the Double Valve and the clutch or brake should be kept to a minimum. For safety reasons **HERION** recommends that no other components be installed between the Double Valve and the brake or clutch.

Care must be taken to avoid particles like metal chips, sealing compound or scale in the piping, which may cause valve failures. The size of pressure regulator, lubricator and filters must be consistent with the inlet port size. An accumulator tank is recommended between the pressure regulator and the Double Valve. The operating pressure must not drop below 30 psig and the use of a pressure switch is suggested. Refer to figure below:

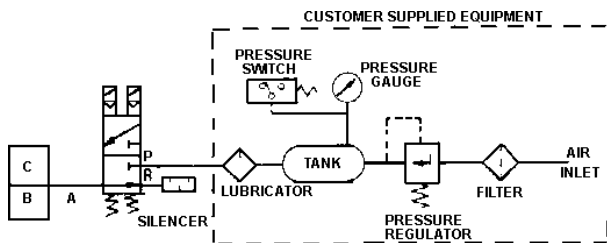

Typical Installation

CAUTION:

DO NOT restrict the exhaust port. Use a muffler or silencer which is resistant to clogging and has a flow capacity at least as great as the exhaust capacity of the Double Valve. Silencer contamination or clogging can increase back pressure and reduce flow. **HERION** expressly disclaims any responsibility for unsatisfactory performance caused by the use of the wrong type, size, or inadequately maintained silencers. See page 5.

WIRING:

The correct power supply voltage and frequency is indicated on the solenoid labels. For proper operation of the dynamic air-logic monitor, both solenoids (2) should be electrically connected in such a way they are energized simultaneously. It is the responsibility of the user, purchaser or installer to comply with OSHA control and redundancy requirements. Consult your local press controls supplier for additional help.

TESTING:

After installing or rebuilding a Double Valve, it is very important that it be tested for proper operation prior to being placed in service.

TEST CONDITIONS:

Fluid: Compressed Air

Test Pressure: 30 and 120 psig

Test Voltage: Per solenoid nameplate less 15%

It is recommended that a Variac be used to obtain the reduced voltage. Reducing the voltage by 15% for the test assures that the valve will operate properly, if voltage fluctuations occur after the valve is placed in service.

TEST PROCEDURE:

CAUTION: The solenoid is powered through a three prong (2 power, 1 ground) connector. Check the solenoid nameplate for the proper voltage prior to making the electrical connection.

1. Plug Port "A" with a pipe plug or gauge. Make sure that the muffler or silencer is installed in Port "R".
2. Connect 30 psig air supply to Port "P".
3. Alternately energize and de-energize both solenoids simultaneously. No malfunction should occur. A malfunction is described as a continuous flow of air through Port "R".
4. Energize only the left hand solenoid. Unit will malfunction.
5. Energize only the right hand solenoid. Unit will malfunction.
6. Energize both solenoids then de-energize the left solenoid. Unit will malfunction.
7. Energize both solenoids then de-energize the right solenoid. Unit will malfunction.

Repeat steps 2 to 7 using 120 psig at Port "P".

SERVICE DATA:

The standard solenoid for the XSz-20 valve is **HERION** model No.0801. The connector conforms to DIN 43650 Form "A" and the combination solenoid / connector meets classification NEMA 4. This **HERION** solenoid is rated at 100% duty cycle and complies with insulation class "F" (155° C).

POWER CONSUMPTION (No. 0801 SOLENOID)

DC : 16 W
AC : 50 VA (Inrush) / 27 VA (Holding)

SERVICE, REPAIR, SPARE PARTS

FACTORY REBUILD PROGRAM

As an economical alternative, **Herion** will rebuild your Press Double Valve and provide a **NEW, ONE-YEAR WARRANTY**. Contact Herion for Return Material Authorization (RMA) and "turnaround" time. If needed we can rebuild your returned valve in 48 hours or supply a NEW or REBUILT Valve in 24 hours.

EMERGENCY

CALL OR FAX: HERION USA

Phone: (724) 776-5577

Fax: (724) 776-0310

WARNING!

Herion recommends that any repair work required on a double valve should be performed by Herion or Herion authorized service personnel. Any customer repair should be carried out by skilled, qualified and trained personnel in accordance with operating and test instructions.

SPARE PARTS

Model	Complete Spare Parts Kits ⁽¹⁾	Seals only Kit ⁽¹⁾	Spare Valve without Base	Factory Rebuilt Valve ⁽²⁾	Operating & Maintenance Manual
XSZ-16	8111280	8111280S	2493900.0201	2493900R.0201	N-269
XSZ-20	8111281	8111281S	2494000.0801	2494000R.0801	N-267
XSZ-32	8111282	8111282S	2494100.0801	2494100R.0801	N-270
XSZ-50	8111283	8111283S	2494200.0801	2494200R.0801	N-271

1) See Operating & Maintenance manual for items in spare parts kit.

2) Rebuilt valve includes a one year Manufacturer's Warranty.

TYPICAL CROSS SECTION

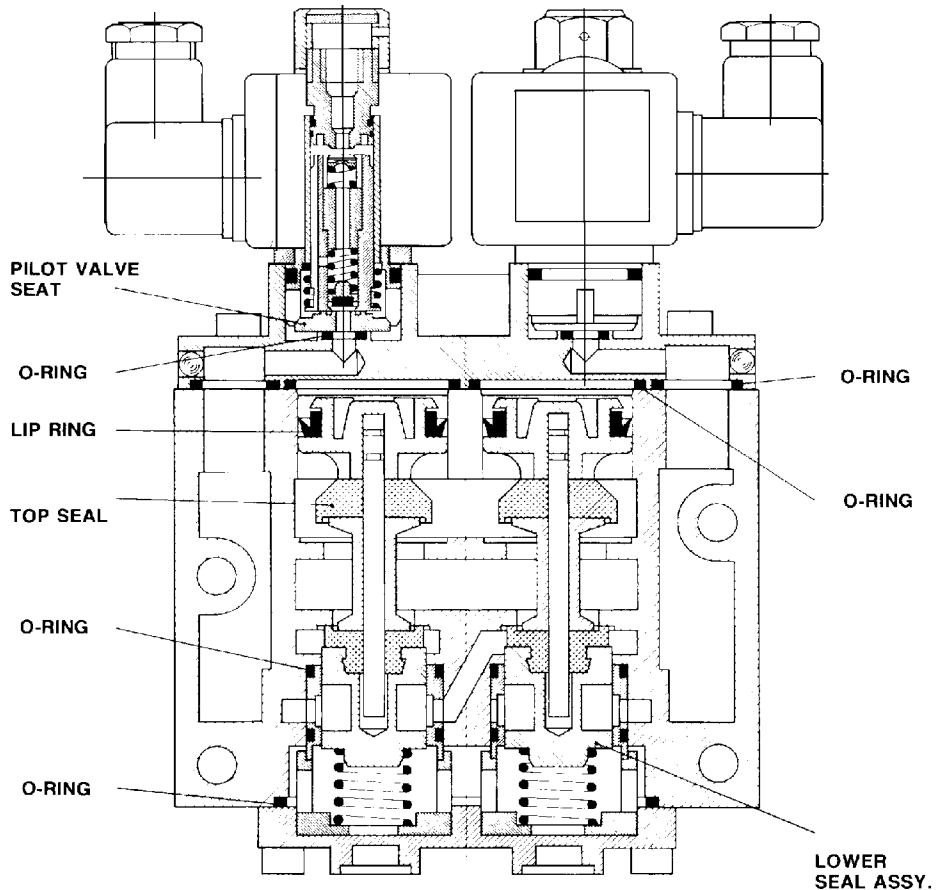

Note: The cross section shown above is typical of the XSz Series of valves, some variation between sizes exists and care should be taken to note the position of parts as they are disassembled. See Operating and Maintenance Manuals for more details.

Year

1982

1977

1976

1966

1956

1950

1948

1938

Safety

is a question of Experience

Crossflow XSz design with dynamic, pneumatic monitoring



Crossflow XS_E design with electro-pneumatic monitoring

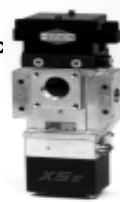

Crossflow XS design with electronic monitoring



3/2 double valve with static monitoring; without residual pressure



3/2 double valve parallel design with static monitoring

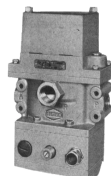

3/2 double valve parallel design



3/2 double valves series design



3/2 Single valve poppet design



History of Safety Valves

Low Safety Factor

High Safety Factor



CAUTION

It is the responsibility of the purchaser and/or installers of the **Herion Double Valve** to make sure that all press controls and components comply with OSHA requirements and to interface valves with press control circuitry.

WARNING

Herion recommends that any repair work required on the double valve should be performed by **HERION USA, Inc.** or authorized distributor. Any customer repair work should be carried out by skilled, trained, and qualified personnel following operating and test instructions.

WARRANTY

Herion warrants its products and equipment to be free from defects in material or workmanship over a period of one year from date of shipment from its factory.

Herion is not responsible for damage to its products through improper installation, maintenance, use repairs or adjustments, or attempts to operate it above the rated capacity or voltage, intentionally or otherwise, or for unauthorized repairs.

No other representations, guarantees or warranties, expressed or implied, are made by Herion Incorporated and foregoing warranty is in lieu of all other representations and warranties, expressed or implied, which are hereby expressly disclaimed and waived by the buyer, including any warranty of merchantability or of fitness for particular purpose.

HERION USA Inc. • 176 Thorn Hill Road • Warrendale • PA 15086
Phone: 724.776.5577 Fax: 724.776.0310
email:sales@herionusa.com