

241 SERIES VAPOR/DUST PROOF

DATE:

FIXTURE TYPE:

PROJECT NAME:

CATALOG #:



FEATURES

UL and ETL listed in U.S. and Canada.
Class I, Division 2, Groups A, B, C & D.
Class II, Division 2, Groups F & G.
Listed for damp locations.
Listed for locations having deposits of readily combustible paint residues.
For paint spray booth applications.
Spring loaded lamp holders



Rear Access Panel

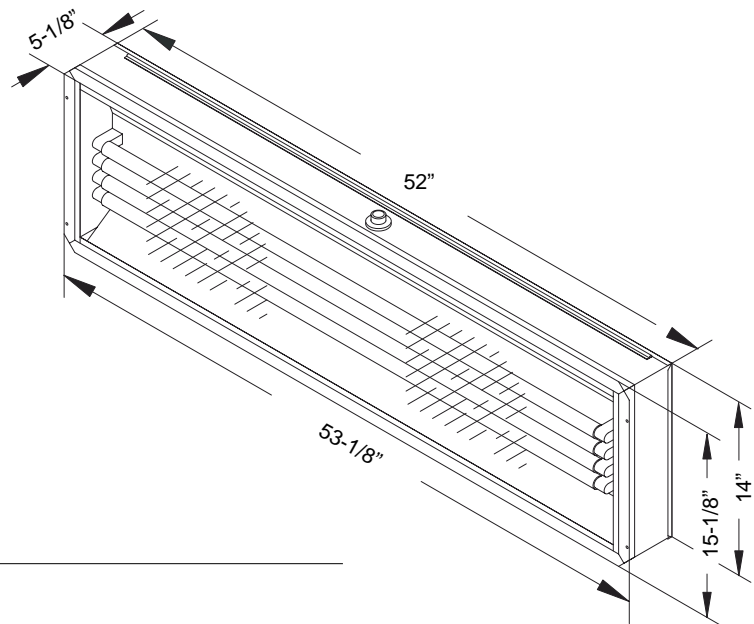

SPECIFICATIONS

- GENERAL:** 4 Ft. 4 lamp rear access fixture
Fabricated to prevent vapor/dust and moisture accumulation.
- HOUSING:** 20 Gauge steel with durable white enamel finish
Piano Hinged rear door for easy access to lamps and ballast.
- LENS:** 3/16" Clear Tempered Glass lens
- MOUNTING:** Compatible with most major brand of paint booths.
- ELECTRICAL:** Available in 32, 40, 44, 54 and 60 watt.
- LISTINGS:** UL and ETL listed in U.S. and Canada
- OPTIONS:** Installation Kit (P/N 36-016-241)

| | Shipping Weight | Volume | Dimensions L W H |
|-----|-----------------|--------------|------------------|
| 241 | | | |
| 32w | 46# | 3.56 Cu. Ft. | 57" L 18" W 6" H |
| 40w | 46# | 3.56 Cu. Ft. | 57" L 18" W 6" H |
| 44w | 46# | 3.56 Cu. Ft. | 57" L 18" W 6" H |
| 60w | 52# | 3.56 Cu. Ft. | 57" L 18" W 6" H |
| 54w | 52# | 3.56 Cu. Ft. | 57" L 18" W 6" H |

For Photometric Information Please Call LDPI®.

241 SERIES VAPOR/DUST PROOF

241 Series
Four Lamp Four Ft.
Front Access Fixture

| Watts | Description | Hub Size (Inches) | Voltage | Catalog Number |
|-------|--|-------------------|------------|----------------|
| 32 | I.S., T8 Electronic F32T8, Med. Bi-Pin, 265 mA, 48" | 1/2 NPT | 120-277V | 390241-3546 |
| | | | /60HZ | 390241347-3125 |
| 40 | R.S., T12, F40T12, Medium Bi-Pin, 430 mA, 48" | 1/2 NPT | 120V/60HZ | 390241120-1289 |
| | | | 277V/60HZ | 390241277-1290 |
| | | | 347V/60HZ | 390241347-3278 |
| 44 | I.S. T8 Electronic F48T8, Recessed Double Contact 48" H.O. | 1/2 NPT | 120V /60HZ | 390241120-4157 |
| | | | 277V/60HZ | 390241277-3792 |
| 60 | R.S., T12 Electronic F48T12, Recessed Double Contact, 800 mA, 48" H.O. | 1/2 NPT | 120V/60HZ | 390241120-3260 |
| | | | 277V/60HZ | 390241277-3222 |
| 54 | P.S., T5 H.O. F54T5, Miniature Bi-Pin | 1/2 NPT | 120V/60HZ | 390241-3265 |
| | | | 277V/60HZ | 290241-3265 |

(Multiple voltages available, consult factory)
LAMPS SOLD SEPARATELY
See pg. 70 for lamp selection

INSTALLATION INSTRUCTIONS

Optional Installation Hardware Kit: P/N 4692

| Item | Description | Qty. |
|------|--|---------|
| 1. | 1/2" x 3/4" Gasket | 12' |
| 2. | Light Clip | 4 |
| 3. | Glass Clip | 2 |
| 4. | Clear Tempered Glass 3/16" x 15" x 53" (not included in kit. P/N 1706) | 1 |
| 5. | 1 1/2" x 1 1/2" Corner Bracket | 4 |
| 6. | Frame (15 3/4" Long) | 2 |
| 7. | Frame (53 1/2" Long) | 2 |
| 8. | 1/8" Pop Rivet | 8 |
| 9. | Nut Hex 1/4 - 20 Zinc Coated HHCS 1/4 - 20 Zinc Coated Installation Sketch | 10 1 |

