

KB II Two-Quart Pressure Cups ■KB-555 Aluminum, KB-545-SS Stainless Steel

IMPORTANT:

Read and follow all instructions and SAFETY PRECAUTIONS before using this equipment. Keep for future reference.

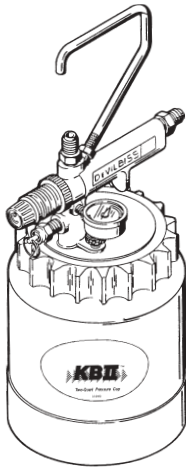

DESCRIPTION

All KB-II style cups are pressure regulated and have a 2.4 quart (77 oz.) capacity. They are designed to be attached to any manual spray gun with air and material hose. The cup may be carried in one hand using the comfortable hand grip or left on the floor while spraying. The KB-II's wide diameter and low profile provides a low center of gravity which increases stability and resists tipping. Models KB-555 and KB-545-SS include a 0-30 psi gauge. KB II cups are supplied with KK-5051 disposable cup liners (5 each) to reduce clean up time and cleaning solvent.

Pressure cups provide a greater degree of control over atomization air and material pressure than obtainable through use of suction feed equipment. Pressure cups also enable user to apply heavy or more viscous materials in small amounts where a 2 quart capacity is sufficient for the job.

INSTALLATION



Risk of injury. Cup is under pressure. Disconnect cup assembly from air supply before installing or removing lid assembly from cup for filling or cleaning.

1. Connect fluid hose (A) to fluid inlet of gun and outlet of cup (1) as shown. See Figure 1.
2. Connect atomization air hose (B) to air inlet of gun and outlet of cup (2) as shown. See Figure 1.
3. Connect air supply hose (C) to inlet coupling (3) on cup handle. See Figure 1.

NOTE

Order hoses separately. See "Accessories", page 4.

OPERATION



Risk of injury or equipment damage. Air pressure to the cup must never exceed 50 psi, (3.5 bar).

Mix and prepare the material to be sprayed according to manufacturer's instructions. Strain material through a 60 to 90 mesh screen or equivalent before spraying. Place KK-5051 disposable liner into cup. Refer to instructions provided with KK-5051.

SPECIFICATIONS

Maximum regulated cup pressure - 50 psi (3.5 bar) (fluid pressure)		
Maximum air inlet pressure (to inlet on handle) - 125 psi (8.5 bar)		
Hose Connections Air - 1/4" NPS(M) Fluid - 3/8" NPS(M)		
Model Nos.	KB-555	KB-545-SS
Height	7-3/16"	7-3/16"
Weight	3 lb. 14 oz.	4 lb. 5 oz.
Fluid Capacity	77 oz. Maximum	
Wetted Parts:		
Cup	Aluminum	304 Electro Polished S.S.
Lid Gasket	Thiokol	Thiokol
Check Valve Assy.	Nylon	Nylon
Fluid Tube Assy.	Aluminum	304 S.S. Passivated
Fluid Tube Nut	Nickel Plated Brass	304 S.S. Passivated
Cup Lid	Aluminum	Electroless Nickel Plated Aluminum
Bleed Down Valve	Nickel Plated Brass	304 S.S. Passivated
KK-5051	Liners	Polyethylene

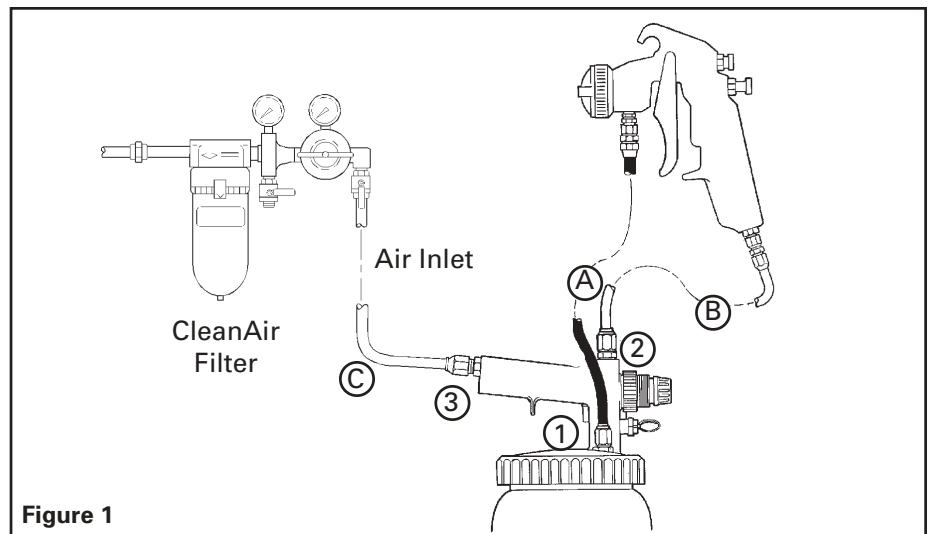

Figure 1

SAFETY PRECAUTIONS

This manual contains important information that ALL users should know and understand BEFORE using the equipment. This information relates to USER SAFETY and PREVENTING EQUIPMENT PROBLEMS. To help you recognize this information, we use the following terms to draw your attention to certain equipment labels and portions of this manual. Pay special attention to any label or information that is highlighted by one of these terms:



Important information that tells how to prevent damage to equipment, or how to avoid a situation that might cause minor injury.





Important information to alert you to a situation that might cause serious injury if instructions are not followed.

NOTE

Information that you should pay special attention to.

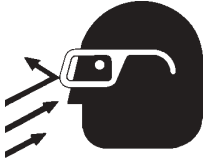

The following hazards may occur during the normal use of this equipment. Please read the following chart.

HAZARD	CAUSE	SAFEGUARD
<p>Spray</p> 	<p>Solvent and coatings can be highly flammable or combustible, especially when sprayed.</p>	<p>Adequate exhaust must be provided to keep air free of accumulations of flammable vapors</p> <p>Smoking must never be allowed in the spray area.</p> <p>Fire extinguishing equipment must be present in the spray area.</p>
<p>Solvent Spray</p> 	<p>During cleaning and flushing, solvents can be forcefully expelled from fluid and air passages. Some solvents can cause eye injury.</p>	<p>Wear eye protection.</p>
<p>Inhaling Toxic Substances</p> 	<p>Certain materials may be harmful if inhaled, or if there is contact with the skin.</p>	<p>Follow the requirements of the Material Safety Data Sheet supplied by your coating material manufacturer.</p> <p>Adequate exhaust must be provided to keep the air free of accumulations of toxic materials.</p> <p>Use a mask or respirator whenever there is a chance of inhaling sprayed materials and its concentration. Equipment must be as prescribed by an industrial hygienist or safety expert, and be NIOSH approved.</p>
<p>Explosion Hazard-Incompatible Materials</p> 	<p>KB-545-SS is stainless steel and can be used with Halogenated Hydrocarbons.</p> <p>KB-555 is aluminum. Solvents such as 1, 1, 1- Trichloroethane and Methylene Chloride (sometimes called methyl chloride) can chemically react with the aluminum used in most spray equipment, and these cups, to produce an explosion hazard.</p>	<p>Read the label or data sheet for the material you intend to spray.</p> <p>Do not use any type of spray coating material containing these solvents with KB-555.</p> <p>Do not use these solvents for equipment cleaning or flushing with the KB-555.</p> <p>If in doubt as to whether a material is compatible, contact your material suppliers.</p>

Description of Controls (Ref. Fig. 2, page 5)
Regulator Assembly (15) - Controls pressure on material in cup.
Pressure Bleed Down Valve (6) - Allows air to be bled from cup

To reduce pressure in cup, turn knob of regulator assembly counterclockwise. Bleed off excess air by momentarily turning pressure relief valve (6) counterclockwise. Readjust pressure by turning knob of regulator (24) assembly clockwise. Turning regulator all the way out shuts off air supply to the cup.

NOTE

Turn pressure bleed valve (6) counterclockwise to vent air from the cup; it is important to do this before removing lid.

1. Place lid on cup. Grasp lid handle and push down with one hand and tighten retaining ring (1) with other hand.
2. Turn regulator knob (24) out (counterclockwise) until no spring pressure is felt.
3. Close pressure bleed valve (6) by turning it in all the way clockwise.
4. Set air supply pressure at approximately 50-60 pounds at transformer.
5. Set material pressure at 10 pounds by turning in regulator knob and reading the gauge. Make sure fluid adjusting screw on spray gun is open (turned out counterclockwise until first thread shows).
6. Test for amount of paint in relation to the speed at which you want to spray. If too much paint is coming out or atomized particle size of paint is too large, follow one of the procedures below.

- A. Turn regulator knob counterclockwise until gauge shows lower pressure. Bleed off excessive air in cup by turning pressure bleed valve (6) counterclockwise.
- B. Raise air pressure at transformer until well defined atomized pattern of paint is evident. This increases air pressure to spray gun while maintaining same pressure in the cup.

PREVENTIVE MAINTENANCE



Always relieve pressure in cup before removing lid by turning bleed valve out.

NOTE

Do not unthread the pressure bleed valve (6) all the way, as it may fall out and be lost.

Cleaning



Do not wash the lid assembly in a gun washer. The safety valve, gauge and regulator contain parts that will be damaged. The cup only can be washed in a gun washer.

Use of the KK-5051 disposable cup liner will significantly reduce cleaning time and solvent. Another accessory item, KK-5052 Adapter and Hose Kit, can also be used in conjunction with the Solvent Saver™ to save further time and solvent cleaning the fluid passages of the tube, hose, and spray gun. See **Accessories** page 4.

Grasp lid handle and push down with one hand and turn the retaining ring (1) counterclockwise with the other hand. Pour out any remaining material and add a suitable solvent. Close cup lid as explained in "OPERATION" section. Spray until clean solvent appears. Cup and gun material passages should now be clean. Empty any remaining solvent from cup. Wipe cup with a solvent soaked cloth.

Check Valve

If contaminated, carefully remove check valve (12) from lid. Soak in suitable solvent. If damaged, replace. Do not torque to more than 10 in. lbs.



The safety valve limits the maximum air pressure. If the safety valve does not work properly, over pressurization may occur and cause the cup to rupture or explode. Occasionally pull the ring on the safety valve and make sure it operates freely. If the valve is stuck or does not operate smoothly, it must be replaced with a valve having the same rating. Never attempt to adjust or disassemble the safety valve.

The safety valve (14) is factory set at approximately 55 lbs. Never disassemble. If damaged, replace. Never submerge in solvents.

Regulator Disassembly

1. Pull the knob on the bonnet outward to unlock regulator knob.
2. Turn the knob counterclockwise to stop.
3. Remove bonnet (24) by turning it counterclockwise. Use pliers if necessary.
4. Remove adjusting screw and nut, regulating spring, slip ring and diaphragm.
5. Use a wide blade screw driver and turn valve seat (18) counterclockwise to remove along with o-ring.
6. Carefully remove valve (17) and valve spring (16).

Regulator Reassembly

1. Place valve spring (16) into center hole of cast housing. Place valve (17) on the spring (16).
2. Use a wide blade screw driver and tighten valve seat and o-ring assembly (18) to 4-6 in. lbs. torque.
3. Place diaphragm (19) on the valve seat. Diaphragm tube must slide freely through valve seat after valve seat is torqued into the body.
4. Place slip ring (20) on inside shoulder of bonnet (24).
5. Place adjusting screw (23), nut (22) and regulating spring (21) into bonnet (24).
6. Tighten bonnet assembly (24) to 65-75 in. lbs. torque.

TROUBLESHOOTING CHART

PROBLEM	CAUSE	CORRECTION
Excess pressure in cup.	Gauge (8) registering incorrectly Safety valve (14) setting too high. Valve spring (16) broken or distorted. Diaphragm (19) damaged. Leak at regulator valve (17 and 18).	Replace. Replace. Replace. Replace. Replace.
Insufficient pressure in cup.	Safety valve (14) leaking. Check valve (12) stuck shut. Gauge (8) registering incorrectly. Leak at cup lid (11) threads.	Replace. Clean or replace. Replace. Tighten cup or replace gasket (9) or slip ring (2).

PARTS LIST

Ref No.	Replacement Part No.	Description	Ind. Parts Req.
1	KB-64	Retaining Ring	1
#2	KB-81-K5	Slip Ring (Kit of 5)	1
*3	KB-74	Handle - Secondary	1
4	---	Nut 5/16"-18 (purchase locally)	1
5	P-MB-51	Adapter	2
#6	KB-66	Pressure Bleed Valve (For KB-555)	1
#	KB-95	Pressure Bleed Valve (For KB-545-SS)	1
7	KB-70	Lid w/handle (For KB-555)	1
	KB-93	Lid w/handle (For KB-545-SS)	1
8	GA-355	Pressure Gauge 0-30 psi	1
#9	KB-80-K5	Gasket (Kit of 5)	1
+10	MBD-11-K5	Locknut (For KB-555, Kit of 5)	1
	KB-97-K2	Locknut (For KB-545-SS, Kit of 2)	1
11	KB-422	2 qt. cup (For KB-555)	1
	KB-442	2 qt. cup (For KB-545-SS)	1
12	KB-432-K3	Check Valve (Kit of 3)	1
#13	KB-85-K5	Gasket (Kit of 5)	1
14	TIA-4355	Safety Valve	1
15	KB-428-1	Regulator Assembly	1
*16	---	Valve Spring	1
*17	---	Valve, Teflon®	1
*18	---	Valve Seat and O-Ring Assembly	1
*19	---	Diaphragm, Teflon® protected	1
*20	---	Slip Ring	1
21	---	Regulator Spring	1
22	---	Nut	1
23	---	Adjusting Screw	1
24	---	Bonnet	1
+25	KB-60-K6	Gasket (Kit of 6)	1
+26	---	Fluid Tube Assembly	1
27	KK-4997	Fluid Tube Kit - (Aluminum For KB-555)	1
	KK-4996	Fluid Tube Kit - (Stainless Steel For KB-545-SS)	1

- These parts are included in the Regulator Repair Kit KK-4887-2.
- # Recommended Spare Parts and KK-4887-2 Repair Kit.
- * A secondary handle (3) has been provided with each cup. May be used for "Belt Hanging".
- ® Registered Trademark of DuPont deNemours.
- + These parts are included in Ref. No. 267, Fluid Tube Kit.
- X Apply thread sealant (i.e. Loctite #242 medium strength blue or equal) unto threads.

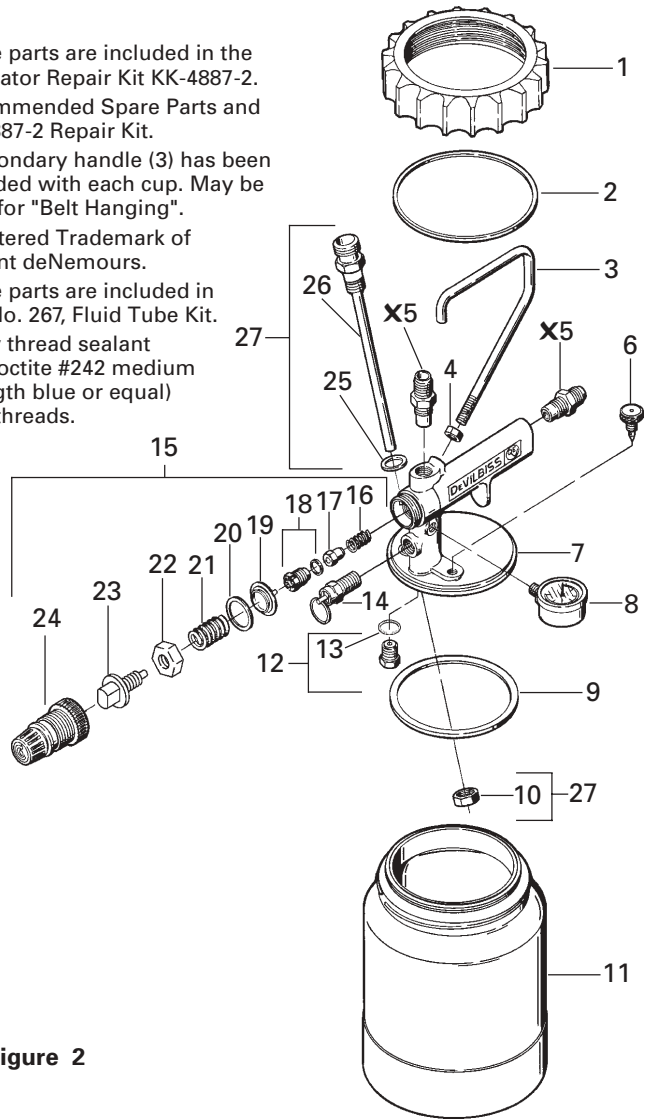

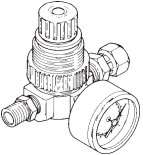

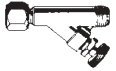
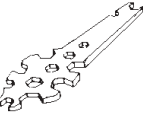

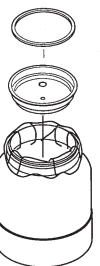
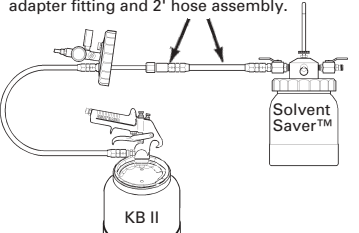

Figure 2

ACCESSORIES

<p>HAV-500 OR HAV-501 Adjusting Valve (HAV-501 SHOWN)</p>  <p>HAV-500 does not have pressure gage. Use to control air usage at gun.</p>	<p>HARG-510 Air Regulator</p>  <p>Use to maintain nearly constant outlet pressure despite changes in inlet pressure and downstream flow.</p>	<p>Spray Gun Lube SSL-10</p>  <p>2oz. Bottle</p> <p>Compatible with all paint materials: contains no silicone or petroleum distillate to contaminate paint. MSDS available upon request.</p>
<p>P-H-5516 Air Adjusting Valve</p>  <p>Enables user to control and reduce air usage at the gun. Ideal for low pressure spraying.</p>	<p>WR-103 Wrench</p>  <p>Contains all necessary tip, hose and nut sizes used on or with gun.</p>	<p>42884-214-K5 3/8" 42884-215-K10 5/8" Cleaning Brushes</p>  <p>These brushes are helpful in cleaning threads and recesses of gun body.</p>

<p>KK-5051 Disposable Cup Liner</p>  <p>Keeps cup and lid isolated from paint reducing clean up time and solvent.</p> <p>Kit includes: 20 liners 20 lids 3 rings</p>	<p>KK-5052 ADAPTER FITTING and HOSE KIT</p>  <p>Allows flushing of cup tube, hose and gun using SolventSaver™. Kit includes: HD-410 adapter fitting and 2' hose assembly.</p>
--	---

KB-4006, 6 ft. Hose Assembly - Includes 6 ft. air hose and 6 ft. fluid hose and connections.

WORLDWIDE SALES AND SERVICE LISTING -
www.devilbiss.com

DeVilbiss Industrial Spray Equipment - DeVilbiss has authorized distributors throughout the world.
FOR TECHNICAL ASSISTANCE OR THE DISTRIBUTOR NEAREST YOU, CALL TOLL FREE 1-888-992-4657 (U.S. and Canada Only).

DeVilbiss Automotive Refinishing - DeVilbiss has authorized distributors throughout the world. For equipment, parts and service, check the Yellow Pages under "Automobile Body Shop Equipment and Supplies".
FOR TECHNICAL ASSISTANCE, CALL TOLL FREE 1-800-445-3988 (U.S. AND CANADA ONLY).

