

# CATA-DYNE™ HEATER

## STANDARD HEATER APPLICATIONS

## INSTALLATION & OPERATION INSTRUCTIONS

**WARNING:** Improper installation, adjustment, alteration, service or maintenance can cause property damage, injury or death. Read the installation, operating and maintenance instructions thoroughly before installing or servicing this equipment.



The Cata-Dyne™ heater can be used in all industrial indoor locations where a source of infrared radiant heat is required, providing adequate ventilation is available.

### CERTIFICATION

Model WX (Series X) Cata-Dyne™ Explosion-proof, flameless infrared catalytic gas heaters are certified by the Canadian Standards Association (CSA) for use in Class I, Divisions 1 and 2, Group D hazardous (classified) locations and Factory Mutual Global (FM), for use in Class I, Division 1, Group D hazardous (classified) locations, temperature code T2C at an ambient temperature of 40°C (104°F).

The Model BX (Series G) Cata-Dyne™ heater is certified by CSA and FM for use in general industrial non-hazardous locations. The MKII model (Series X) Explosion-proof, flameless infrared catalytic gas heater is certified by CSA for use in Class I, Divisions 1 and 2, Group D hazardous (classified) locations. Models listed are certified for industrial use only, for either natural gas or propane gas. CSA approved models are equipped for high altitudes: 0 - 4,500 ft. (0-1,370 m) above sea level.

### INSTALLATION

To ensure maximum efficiency of your Cata-Dyne™ heater, it should be installed with the heating surface positioned plus or minus 45° from the vertical plane at a height of no more than 8 ft.(2.44 m). All heaters must be installed in accordance with the latest revisions of the codes described in the table below and in accordance with any local codes and regulations. Before installing the heater, all information on the heater

### Cata-Dyne™ Heater - Models Available

WX Model (Series X)					
Approved for use in Class I, Division 1 and 2, Group D hazardous (classified) locations by both FM and CSA					
Model Number	Specifications (Btu/hr Input Ratings) For Both Natural and Propane Gas		Model Number	Specifications (Btu/hr Input Ratings) For Both Natural and Propane Gas	
	Max. Btu/hr	Max. kW		Max. Btu/hr	Max. kW
WX 6 x 6	1,000 Btu/hr	0.293 kW	WX 18 x 24	12,000 Btu/hr	3.514 kW
WX 6 x 12	2,000 Btu/hr	0.586 kW	WX 18 x 30	15,000 Btu/hr	4.393 kW
WX 6 x 24	4,000 Btu/hr	1.171 kW	WX 18 x 36	18,000 Btu/hr	5.272 kW
WX 6 x 60	10,000 Btu/hr	2.929 kW	WX 18 x 48	24,000 Btu/hr	7.029 kW
WX 8 x 8	1,778 Btu/hr	0.521 kW	WX 18 x 60	30,000 Btu/hr	8.786 kW
WX 10 x 12	3,333 Btu/hr	0.976 kW	WX 18 x 72	36,000 Btu/hr	10.543 kW
WX 12 x 12	4,000 Btu/hr	1.171 kW	WX 24 x 24	16,000 Btu/hr	4.686 kW
WX 12 x 24	8,000 Btu/hr	2.343 kW	WX 24 x 30	20,000 Btu/hr	5.857 kW
WX 12 x 36	12,000 Btu/hr	3.514 kW	WX 24 x 36	24,000 Btu/hr	7.029 kW
WX 12 x 48	16,000 Btu/hr	4.686 kW	WX 24 x 48	32,000 Btu/hr	9.372 kW
WX 12 x 60	20,000 Btu/hr	5.857 kW	WX 24 x 60	40,000 Btu/hr	11.715 kW
WX 12 x 72	24,000 Btu/hr	7.029 kW	WX 24 x 72	48,000 Btu/hr	14.058 kW

BX Model (Series G)					
Approved for use in general industrial non-hazardous locations by both FM and CSA					
Model Number	Specifications (Btu/hr Input Ratings) For Both Natural and Propane Gas		Model Number	Specifications (Btu/hr Input Ratings) For Both Natural and Propane Gas	
	Max. Btu/hr	Max. kW		Max. Btu/hr	Max. kW
BX 6 x 6	1,500 Btu/hr	0.4 kW	BX 18 x 24	18,000 Btu/hr	5.3 kW
BX 6 x 12	3,000 Btu/hr	0.9 kW	BX 18 x 30	22,500 Btu/hr	6.6 kW
BX 6 x 24	6,000 Btu/hr	1.8 kW	BX 18 x 36	27,000 Btu/hr	7.9 kW
BX 8 x 8	3,500 Btu/hr	1.0 kW	BX 18 x 48	36,000 Btu/hr	10.5 kW
BX 10 x 12	5,000 Btu/hr	1.5 kW	BX 18 x 60	45,000 Btu/hr	13.2kW
BX 12 x 12	6,000 Btu/hr	1.8 kW	BX 18 x 72	54,000 Btu/hr	15.8 kW
BX 12 x 24	12,000 Btu/hr	3.5 kW	BX 24 x 24	24,000 Btu/hr	7.0 kW
BX 12 x 36	18,000 Btu/hr	5.3 kW	BX 24 x 30	30,000 Btu/hr	8.8 kW
BX 12 x 48	24,000 Btu/hr	7.0 kW	BX 24 x 36	36,000 Btu/hr	10.5 kW
BX 12 x 60	30,000 Btu/hr	8.8 kW	BX 24 x 48	48,000 Btu/hr	14.1 kW
BX 12 x 72	36,000 Btu/hr	10.5 kW	BX 24 x 60	60,000 Btu/hr	17.5 kW
			BX 24 x 72	72,000 Btu/hr	21.0 kW

MKII Model (Series X)		
Approved for use in Class I, Division 1 and 2, Group D hazardous (classified) locations by both FM and CSA		
Model Number	Specifications (Btu/hr Input Ratings) For Both Natural and Propane Gas	
	Max. Btu/hr	Max. kW
MKII 12 x 12	4,000 Btu/hr	1.171 kW
MKII 12 x 24	8,000 Btu/hr	2.343 kW
MKII 18 x 24	12,000 Btu/hr	3.514 kW
MKII 24 x 24	16,000 Btu/hr	4.686 kW

Model WX Series Heaters are certified for use in Class I, Division 1 and 2, Group D hazardous locations by both FM and CSA/CGA

The WX Series Cata-Dyne™ features an improved efficiency catalyst pad that requires 1/3 less fuel to generate the same heat value as our BX Series Cata-Dyne™ heater.



Head Office & Factory:  
 5918 Roper Road, Edmonton, Alberta, Canada T6B 3E1  
 Telephone: (780) 466-3178 Fax: (780) 468-5904  
 Toll Free: 1-800-661-8529

E-mail: info@ccithermal.com

www.ccithermal.com

nameplate must be carefully reviewed. The nameplate lists all the fuel and electrical requirements for the heater.

All Cata-Dyne™ Heaters Installed in Canada	All Cata-Dyne™ Heaters installed in the United States
CSA/CAN – C22.1-02, Canadian Electrical Code CSA/CAN – B149.1-00, Natural Gas and Propane Installation Code	NFPA 70, National Electrical Code NFPA 54, National Fuel Gas Code

## SPECIFICATIONS

### Clearances

Appropriate clearances from the heating surface must be observed during the installation of the Cata-Dyne™ heaters (See Figure 1). Maintain nameplate clearances from combustible materials such as wood, cloth, paper, etc.

### Fuels

The Cata-Dyne™ flameless gas heater is designed to operate on clean, dry natural or propane gas as specified

on the heater nameplate.

**Natural Gas** – these heaters are designed to use natural gas (1000 Btu/ft<sup>3</sup>, 37 MJ/m<sup>3</sup>) at 7 in. w.c. (1.73 kPa), 4.5 in. w.c. (1.12 kPa), or 3.5 in. w.c. (0.86 kPa).

**Propane** – these heaters are designed to use propane gas (2500 Btu/ft<sup>3</sup>, 88 MJ/m<sup>3</sup>) at 11 in. w.c. (2.72 kPa).

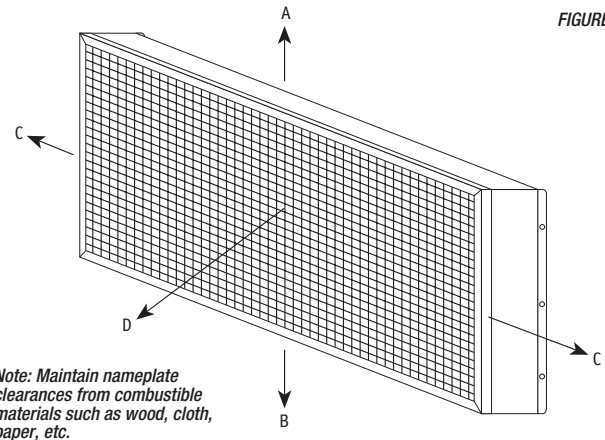

FIGURE 1

Note: Maintain nameplate clearances from combustible materials such as wood, cloth, paper, etc.

HEATER CLEARANCE										
	Radiant Surface			Sides	Top			Bottom		
Radiant Surface Position	Heaters Up To 12,000 Btu/hr	Over 12,000 Up To 48,000 Btu/hr	Over 48,000 Up To 72,000 Btu/hr	All Heaters Up To 72,000 Btu/hr	Heaters Up To 12,000 Btu/hr	Over 12,000 Up To 48,000 Btu/hr	Over 48,000 Up To 72,000 Btu/hr	Heaters Up To 12,000 Btu/hr	Over 12,000 Up To 48,000 Btu/hr	Over 48,000 Up To 72,000 Btu/hr
Vertical (0°)	28 in.	42 in.	60 in.	12 in.	18 in.	18 in.	42 in.	7 in.	12 in.	18 in.
0-45° up	28 in.	42 in.	60 in.	12 in.	18 in.	32 in.	54 in.	0 in.	12 in.	18 in.
0-45° down	28 in.	42 in.	60 in.	12 in.	18 in.	18 in.	18 in.	22 in.	24 in.	42 in.

### Piping

1. A main shut-off valve must be installed upstream of all auxiliary heater controls.
2. The 100% safety shut-off valve and appliance regulator (natural gas heaters only) must be installed in the upright position.
3. The thermostatic temperature controller should be installed with the dial shaft in the horizontal position.
4. The maximum inlet pressure to the 100% safety shut-off valve, thermostatic temperature controller and appliance regulator is 1/2 psi (3.4 kPa). If the inlet pressure is higher than this, a low-pressure service regulator must be installed upstream of these components.
5. The maximum inlet pressure to the low-pressure service regulator is 250 psi (1.7 MPa). If the inlet pressure is higher than this, a high-pressure regulator must be installed upstream.
6. All components should be installed as indicated in Figure 2 (WX and BX models only) or Figure 3 (MKII model only).

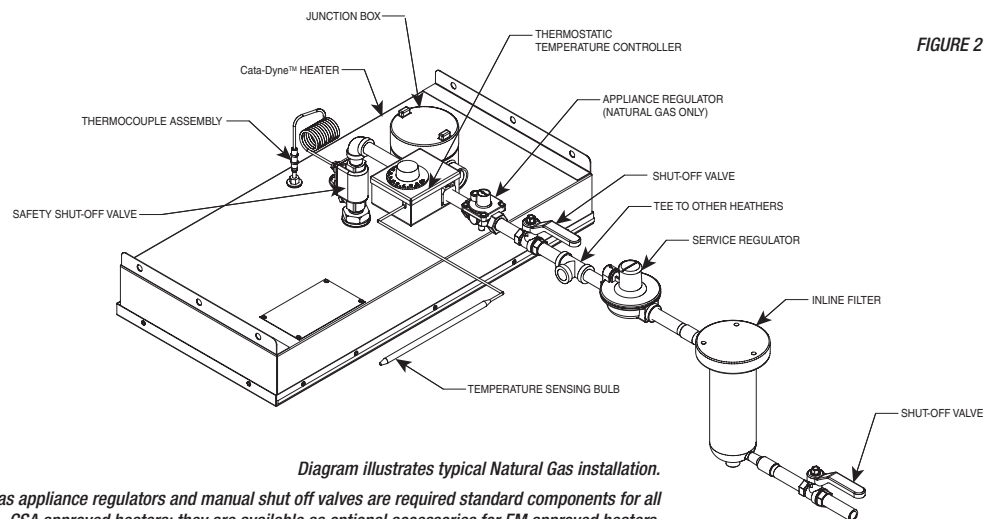

FIGURE 2

Diagram illustrates typical Natural Gas installation.

Gas appliance regulators and manual shut off valves are required standard components for all CSA approved heaters; they are available as optional accessories for FM approved heaters.

## Electrical

1. All wiring is to be installed in accordance with the latest revisions of the Canadian Electrical Code (CEC) and/or any applicable local codes.
2. It is desirable to install an indicating light on all starting systems. This will reduce the possibility of the power being left on once the heater is started, which can severely reduce the lifespan of the heater.
3. Ground connections for 120 V and above heaters are required as indicated in Figures 4 and 5.
4. The number of terminals in the junction box can be two or four depending on the number of elements used in the fabrication of the heater. All MKII models incorporate a single element and therefore have only two terminals. The connection procedure for the different combinations is as described in Figures 4 and 5:

## Ventilation

The catalytic reaction in Cata-Dyne™ heaters occurs when natural gas or propane reacts with oxygen to produce water vapor, carbon dioxide and infrared energy. Ventilation must be provided to allow an adequate supply of oxygen for the reaction.

For every 1.0 ft<sup>2</sup> (0.093 m<sup>2</sup>) of heater surface, 40 ft<sup>3</sup>/hr (1.13 m<sup>3</sup>/hr) of air supply is required. For example, a WX 24 x 24 heater (16,000 Btu/hr / 4.686 kW ) would require 160 ft<sup>3</sup>/hr (4.53 m<sup>3</sup>) of air to ensure proper operation of the Cata-Dyne™ heater.

To reduce the carbon dioxide and water vapor concentrations in the building, a vent hood assembly can be installed to provide positive ventilation from the heater (See Figure 6).

FIGURE 4

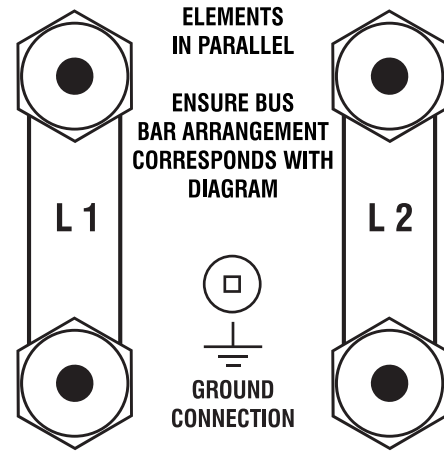

FIGURE 5

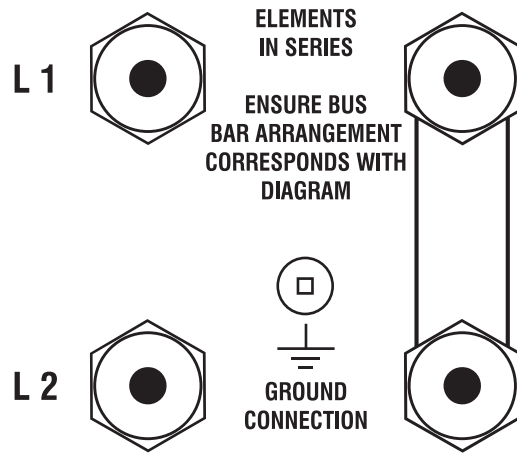

FIGURE 3

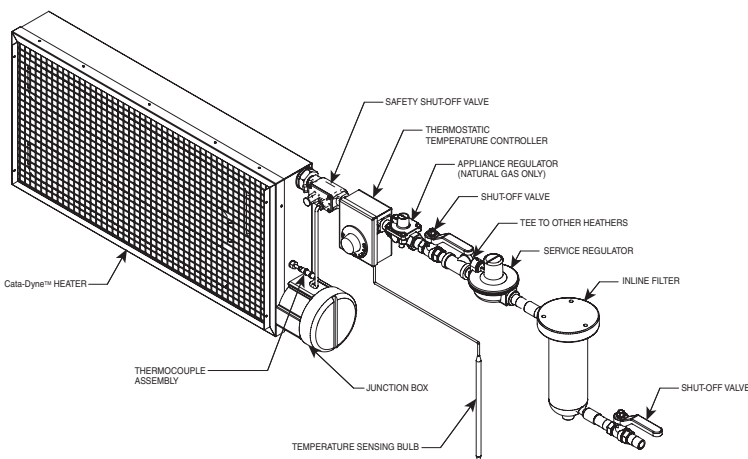
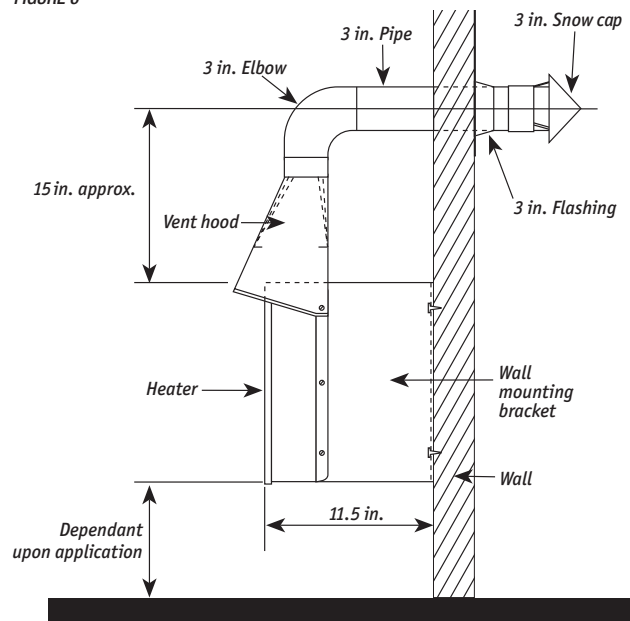

Diagram illustrates typical Natural Gas installation.

Gas appliance regulators and manual shut off valves are required standard components for all CSA approved heaters; they are available as optional accessories for FM approved heaters.

FIGURE 6



## OPERATION

All Cata-Dyne™ heaters are supplied with a Safety Shut-Off Valve (SSOV)/Thermocouple assembly to ensure the safe operation of the heater. Under no circumstances should the reset button be held or locked into the depressed position by use of a mechanical restraint. A tamper resistant model SSO V is available if desired.

### Start-up

1. Ensure the heater has been installed according to all instructions and relevant codes.
2. Turn on the main gas supply to the system.
3. If the heater is equipped with a thermostatic temperature controller, rotate the dial completely clockwise to the fully open position.
4. Turn on the power to the electrical elements.
5. After 15 minutes, depress the reset button on the top of the 100% safety shut-off valve. The button should return to the original position and internally open the valve and allow gas to flow to the heater. If the valve does not stay open when the reset button is released, it may be necessary to wait an additional few minutes and then depress the reset button again. This will allow the electrical elements additional time to warm up.
6. When the catalytic reaction is well established, turn off the electrical power to the elements.
7. If the heater is equipped with a thermostatic temperature controller, it can be set to the desired setting after the catalytic reaction has been established for at least one hour.

### Shut down

Turn off the gas supply to the heater.

### Multi-heater start-up

Cata-Dyne™ heaters can also be purchased/installed in multi-heater assemblies. If these assemblies are 12 V, each heater must be started individually. This ensures the correct voltage and current will be reaching the heater from the power supply.

## 12 V HAZARDOUS ELECTRICAL INSTALLATIONS

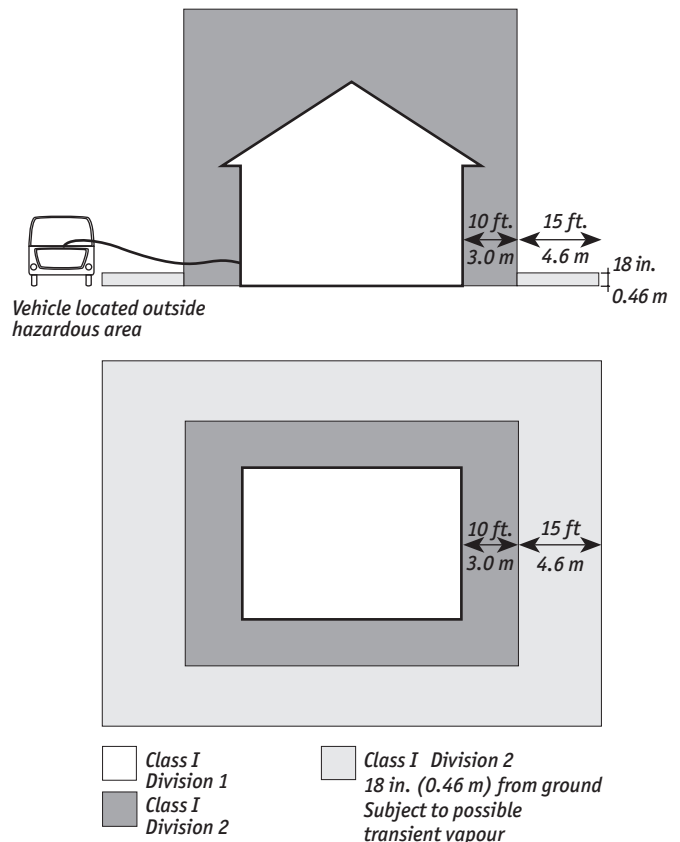

Most oil and gas production buildings have an area classification as follows:

1. Class I, Division 1, within the building.
2. Class I, Division 2, outside the building for a distance of 10 ft.(3.0 m) from the building at all elevations.
3. Class I, Division 2, outside the building for a distance of 25 ft.(4.5 m) from the building at an elevation of 18 in. (0.45 m) from the ground.

All electrical apparatus and wiring within this area must conform to the appropriate codes. Connection to the power supply must be outside of the Class I, Division 2 location.

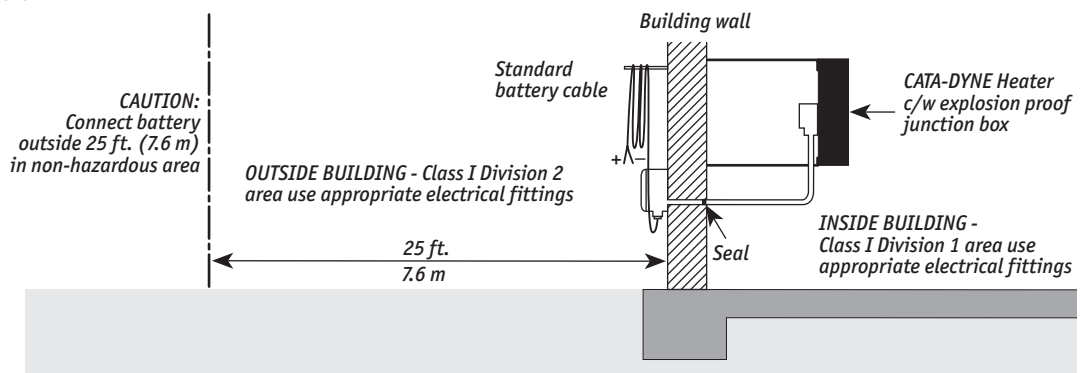

## SPOT HEATING

There are several factors to consider when Cata-Dyne™ heaters are utilized for spot heating.

Infrared energy travels in straight lines from the face of the Cata-Dyne™ heater covering approximately 160° of arc and is inversely proportional to the square of the distance. The heater should therefore be mounted as close as practical (min. of 8 in. (20 cm)) to the object requiring heat for maximum temperature rise.

Match the shape of the object requiring heat with the appropriate Cata-Dyne™ heater, e.g. WX/BX 6 x 24 for long narrow objects or WX/BX 12 x 12 for a square object.

Objects requiring heat should be painted dull, dark colors for maximum infrared absorption and objects not requiring heat should be painted light or reflective colors.

Insulate and protect plastic, rubber and similar materials from direct intense infrared heat.

## SPACE HEATING

A separate heat load calculation should be done for each building in which a Cata-Dyne™ heater will be installed for space heating purposes.

The heat load calculation determines the building heat losses through the structure and allows for air infiltration (refer to the sample Heat Load Calculation in the Cata-Dyne™ catalogue).

Cata-Dyne™ heaters produce low intensity infrared heat that is absorbed by objects within the range of the heat source. The closer the object is to the source of heat, the more heat the object will absorb. Cata-Dyne™ heaters should be placed close to the floor level within the building to heat objects close to the floor.

Ideally, Cata-Dyne™ heaters should be mounted 1-3 ft.(0.3-1 m) from the floor and equally spaced around the building perimeter for space heating applications.

If low mounting is not practical, then overhead mounting may be utilized. Overhead mounted heaters should be sloped face down to a maximum 45° angle to direct the infrared energy towards the floor. Overhead mounting should be restricted to heaters of 30,000 Btu/hr (8.8 kW) capacity and larger.

If the building requires only one heater, place the Cata-Dyne™ heater as close as possible to the center of the longest wall.

For multiple heater installations, space the Cata-Dyne™ heaters as evenly as possible around the perimeter of the building.

Make sure the piping is large enough to handle the gas load (refer to the sample Piping Calculation in the Cata-Dyne™ catalogue for sizing information).

Make sure the electrical starting system has sufficient current carrying capacity and conforms to all applicable electrical codes.

It is advisable to install an indicator light in the electrical circuit to reduce the possibility of the power being left on once the heater is started.

## PERSONAL SAFETY

The Cata-Dyne™ flameless infrared catalytic gas heater does not produce harmful carbon monoxide gas when used with natural gas or propane. Adequate ventilation must be incorporated in any building design to ensure oxygen replenishment and removal of any carbon dioxide. Protective grills should be used on any installation where personnel may come in contact with the face of the heater.

## ORDERING INFORMATION

You can order any of CCI Thermal's products by telephone, fax, mail or e-mail. To assist us in processing your order as quickly and efficiently as possible, please provide us with the following information:

- ◆ Cata-Dyne™ product name
- ◆ Cata-Dyne™ model number
- ◆ Fuel gas - natural gas or propane
- ◆ Starting voltage - 12, 24, 120, 208, 240, 480, or 600 V
- ◆ Accessories required:
  - Protection Grill
  - Wall Mount Brackets
  - Thermostat
  - Regulator
  - Start Up Leads (12 V system only)
  - Vent Hood
  - Other
- ◆ Company name and contact
- ◆ Billing address, phone number, fax or e-mail
- ◆ Shipping address and phone number
- ◆ Shipping instructions
- ◆ Special tagging instructions
- ◆ Date required
- ◆ Method of payment:
  - on account - P.O. number required
  - credit card - Visa or Mastercard number
  - cash or cheque

## GUARANTEE

CCI Thermal warrants all Cata-Dyne™ flameless infrared heaters sold to be free from defects in material or workmanship under normal use and service. The company agrees to repair or replace any Cata-Dyne™ heater which, upon its examination, reveals it to have been defective due to faulty workmanship or material, if returned to our factory, transportation PREPAID, within one (1) year from date of purchase. The company does not assume responsibility for misuse or misapplication of its heaters.

Warranty is void if Cata-Dyne™ heaters are used with sour, dirty or wet gas, or where sulphur content is greater than allowable for utility gas specifications. Warranty is void if, upon our inspection, the heater has been tampered with. Neither CCI Thermal nor the selling dealer shall be held responsible for loss of time, inconvenience, commercial loss or consequential damages relating to the use of Cata-Dyne™ heaters.

## RETURN GOODS POLICY

Prior written approval must be obtained from CCI Thermal for the return of any Cata-Dyne™ product(s). A restocking charge of 15% will apply. All returns must be shipped to our factory in Edmonton, freight prepaid. Final acceptance will be contingent on inspection at our factory.

## REPAIRS

Cata-Dyne™ heaters may require periodic maintenance or repair. Our factory is staffed with technicians who are qualified to perform any required repairs. The procedure to follow to have a heater repaired is as follows.

Send the heater to our factory in Edmonton. Include the following information with the heater:

- ◆ Company name and address
- ◆ Contact name
- ◆ Telephone number/fax number/e-mail
- ◆ P.O. number
- ◆ Advise if an estimate is required prior to starting the repair
- ◆ Details on the repair or conversion required
- ◆ Return shipping instructions

**NOTE:** Under the terms of our certification, all repairs must be performed at our factory in Edmonton.

## TROUBLE SHOOTING

1. Ensure that the fuel matches that listed on the nameplate.
2. Ensure that the voltage matches that listed on the nameplate.
3. Check for any physical damage. All signs of physical damage to the catalyst pad such as holes, tears or a general deterioration of the catalyst bed signal that it is time to have the heater repaired.
4. Check the gas supply pressure at the heater – 7 in. w.c. (1.73 kPa), 4.5 in. w.c. (1.12 kPa), or 3.5 in. w.c. (0.86 kPa) for natural gas and 11 in. w.c. (2.72 kPa) for propane.
5. Check the gas orifice for obstructions or dirt and ensure the size matches that listed on the nameplate. It may be necessary to install a filter upstream of the heater or regulator if the gas supply is dirty. If the fuel supply is constantly dirty and/or wet it would be advisable to use bottled propane fuel.
6. Check the mounting position of the heater. The face of the heater should be preferably in the vertical position and should not vary more than 45° from the vertical position for maximum efficiency.
7. Check for saturation of the catalyst face caused by condensation or rain running down the face of the heater. If the heater has been exposed to water, it is advisable to place the unit in a warm area for a period of a few hours or longer if required. Once the moisture is removed, the heater can be re-installed and re-started.
8. Check the jumper cable size to ensure that the resistance of the cable is not reducing the current to the heater. This would not allow sufficient power to the electrical element to preheat the catalyst to the activity temperature. It is recommended to run the service vehicle at fast idle while starting the heater.
9. Cata-Dyne™ heaters are designed to use clean fuel and to be used in non-contaminated atmospheres. Sulphur compounds in the fuel or atmosphere will poison the catalyst bed over a period of time and render the heater inoperative. If the heater has been exposed to sulphur compounds, it should be sent to the factory for service.
10. Avoid spraying the face of the heater with high-pressure air, steam or water because this can damage the catalyst bed. If physical damage is visible, return the heater to the factory for servicing.
11. Ensure that the temperature controller is correct for the model size, fuel, and pressure specifications for the heater it is fitted to. If the temperature controller is too low, the heater will not have sufficient fuel rating to operate and will stop.

*Separate Installation and Operation Instructions are available for oven and industrial heating applications.*