

120175 (GFC-502) 1 Liter Aluminum Gravity Feed Cup

Important: Before using this equipment, read all safety precautions and instructions. Keep for future use.



Halogenated Hydrocarbon Solvents - for example: 1, 1, 1-trichloroethane and methylene chloride can react with the aluminum in this cup and cause an explosion hazard. Read the data sheet for the material you intend to spray. Do not use spray materials containing these solvents with this cup.

DESCRIPTION

120175 (GFC-502) 1 Liter Cup

This cup is designed to be used with or without the DeVilbiss disposable cup liner. The cup liner allows painting in any position and simplifies clean up.

The cup is constructed from durable aluminum to provide trouble-free operation. The cup insert is electroless nickel plated brass. The disposable cup lid is recyclable and is constructed with recycled polyethylene. The lid has a unique drip check to prevent paint from dripping out of the vent in the lid.

ASSEMBLY OF CUP TO GUN

1. Remove one of the cup gaskets (#4 (White) for GFG and GFHV guns) (#4A (Blue) for GTI, FLG and M1-G guns) from the poly bag.
2. Place this cup gasket in the fluid inlet of the gun body. See Cup Drawing.
3. Store remaining cup gasket in a safe place for future use.
4. Place filter (3) in cup outlet at this time if desired. See Cup Drawing.
5. Assemble cup to gun and tighten hand tight.

FILLING WITH PAINT

Fill the cup with paint to the full mark. Do not overfill.

INSTALLING THE LID

Place plastic lid on the top of the cup, and push in the center of the lid to assemble lid. Fold vent cap and push onto center portion of lid (if vent cap is not already assembled).

CLEANING

Note

For routine cleaning, it is not necessary to remove cup from gun. Do not remove washer (4) from gun. If washer (4) is removed, it must be replaced.



Do not soak the lid in solvent for extended periods of time. Doing so could cause cup/lid sealing problems and leakage.

The cup lid is designed to be disposable but may be cleaned and reused if slightly contaminated with overspray. **If lid becomes tight, or does not fit, it is due to extended soaking in solvent. Let lid air dry overnight and the lid should return to its original size and fit.**

Remove lid and properly dispose of any excess paint. Pour in a small amount of clean solvent. The amount will vary with different coatings and solvents. Reinstall lid. Shake cup to wash down the inside surfaces. **Hold lid while shaking to prevent lid from coming off.** Pull trigger to allow some solvent to be flushed through gun. Remove lid and pour out dirty solvent. Add a small amount of clean solvent and repeat procedure. Wipe exterior of lid with a clean cloth and clean solvent.

If a paint filter was used in the bottom of the cup outlet, it should be removed and cleaned or replaced at this time. Dispose of used cup lid if contaminated and replace with new.

Cup Drawings

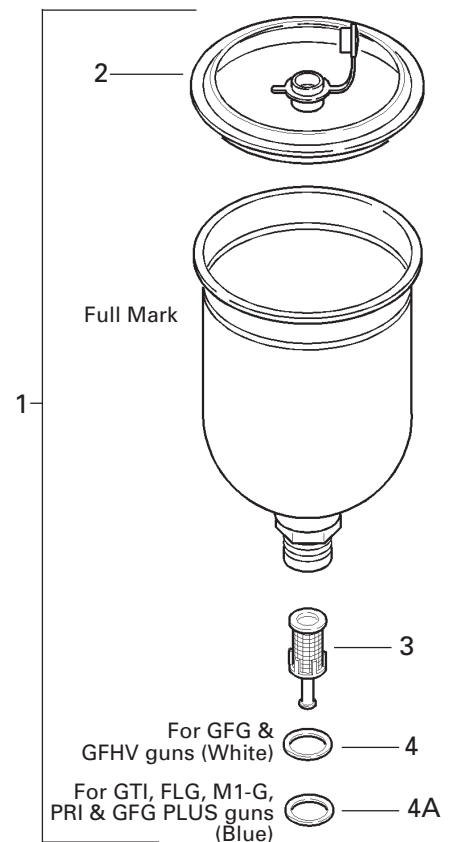
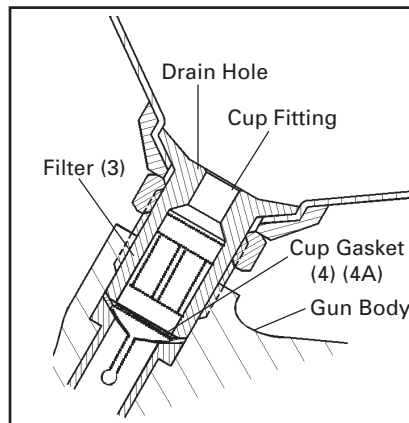

PARTS LIST

Ref. No.	Replacement Part No.	Description
1	GFC-502	Metal Gravity Feed Cup
2	GFC-404-K2	Disposable Lid Kit (Kit of 2)
3	KGP-5-K5	Filter Kit (Kit of 5)
4	KGP-12-K5	Cup Gasket (White) (Kit of 5)
4A	KGP-13-K5	Cup Gasket (Blue) (Kit of 5)

ACCESSORIES

**OMX-70-K48 PAINT CUP LINER KIT
(Not for use with GFC-503 cups)**

Allows quick and easy clean-up.

Consists of :

- 1 - Piercing Tool
- 48 - Disposable Liners
- 48 - Drain Bushings

WARRANTY

This product is covered by DeVilbiss' 1 Year Limited Warranty.

DeVilbiss Worldwide Sales and Service Listing: www.devilbiss.com

ITW Industrial Finishing

DeVilbiss has authorized distributors throughout the world. For technical assistance or the distributor nearest you, see listing below.

U.S./Canada Technical Service Office:

195 Internationale Blvd., Glendale Heights, IL 60139
Toll-Free Telephone: 1-888-992-4657 (U.S.A. and Canada only)
Toll-Free Fax: 1-800-368-8401

ITW Automotive Refinishing

DeVilbiss has authorized distributors throughout the world. For equipment, parts and service, check the Yellow Pages under "Automotive Body Shop Equipment and Supplies." For technical assistance, see listing below.

U.S./Canada Customer Service Office:

1724 Indian Wood Circle, Suite J-K, Maumee, OH 43537
Toll-Free Telephone: 1-800-445-3988 (U.S.A. and Canada only)
Toll-Free Fax: 1-800-445-6643

DEVILBISS