

## TLC-576 & TSC-591 HVLP LOW PRESSURE ONE QUART CUP

### IMPORTANT:

Read and follow all instructions and SAFETY PRECAUTIONS before using this equipment. Retain for future reference.

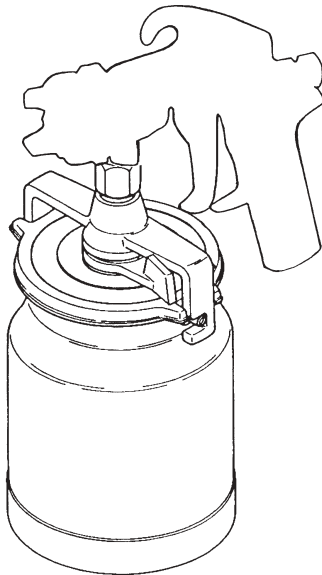

### DESCRIPTION

These cups have a 1 quart capacity, for pressure feed use with cup pressure regulation. The TLC-576 Teflon® lined cup is suitable for use with most common coating materials, where small amounts of material or many color changes are required.

The TSC-591 is a high quality, stainless steel cup designed for use with corrosive type materials such as waterbornes. It is also suitable for use with finishes containing halogenated hydrocarbon solvents.

Both cups are used with KK-4980 air regulator kit (order separately).

Maximim working pressure: 20 psi (1.4 bar), connecting thread 3/8" NPS.

The Teflon cup check valve will prevent the cup from losing pressure. The check valve also prevents paint from backing up into the air tube if the cup is tilted. The poppet stem in the cup lid allows the painter to manually relieve the cup pressure.

### INSTALLATION

1. Position yoke at right angles to the gun body with the cam (3) towards the front of the gun.
2. Fasten lid assembly (11) to fluid connector on the gun and tighten nut with wrench.
3. Connect the air supply tube from regulator to the fitting (8) on the lid.

### OPERATION

#### WARNING

**Risk of injury. Cup is under pressure during operation. Turn off or disconnect air supply to spray gun and paint cup before attaching or removing the cup and cup lid and before filling or cleaning. Turn the cup regulator knob counterclockwise to shut off air to the paint cup. Push down on the check valve poppet stem (6) to relieve the cup pressure.**

#### WARNING

**Risk of injury or equipment damage. Air pressure to the cup must never exceed 20 psi (1.4 bar).**

1. Mix, prepare and strain the material. Remove cup (12) by moving the cam lever counter-clockwise, fill cup. **Do not overfill.**

#### Note

Only use a wooden or plastic paddle or mixer for mixing material in the Teflon® cup (TLC-401). A metal paddle or mixer can scratch the teflon lining.

2. Replace cup (12), engage pins into yoke slots (make sure both pins are fully engaged in both slots prior to tightening) and tighten by moving cam lever (3) clockwise. Do not lubricate cam. This can cause it to loosen.
3. Connect air supply to gun. Make sure gun inlet pressure and cup pressure do not exceed maximum limits.
4. Before refilling or emptying the contents of the cup, depressurize the cup by pushing down on the check valve poppet stem (6) to relieve pressure from the cup. If the check valve has become wet it is normal for a small amount of paint mist to be discharged from stem hole.

#### Note

Horizontal spraying with a full cup could allow paint to contact the check valve. This could affect the operation. Check valve (10) should be cleaned after each use.

### MAINTENANCE

#### Lid Repair/Replacement

1. To replace a damaged part, use a 5/16 inch Allen wrench to loosen and remove adapter (1). Nut (2), yoke and cam (3), lid and tube assembly are now loose for replacement.
2. Replace damaged parts on the lid and tube assembly.

#### Note

To prevent leakage when reinstalling adapter (1), apply sealant (Loctite #262) to the first two full threads.

3. Insert threaded end of the adapter (1) into open end of nut (2).
4. Install adapter and nut in top of lid and tube assembly. Use a 5/16-inch Allen wrench to tighten firmly (10-12 Ft. Lbs.).

**SAFETY PRECAUTIONS**

This manual contains important information that ALL users should know and understand BEFORE using the equipment. This information relates to USER SAFETY and PREVENTING EQUIPMENT PROBLEMS. To help you recognize this information, we use the following terms to draw your attention to certain equipment labels and portions of this manual. Pay special attention to any label or information that is highlighted by one of these terms:



**Important information that tells how to prevent damage to equipment, or how to avoid a situation that might cause minor injury.**





**Important information – a hazard that may cause serious injury or loss of life.**

**Note**

Information that you should pay special attention to.

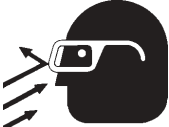

**The following hazards may occur during the normal use of this equipment. Please read the following chart.**

Hazard	Cause	Safeguards
<p><b>Fire</b></p> 	<p>Solvent and coatings can be highly flammable or combustible, especially when sprayed.</p>	<p>Adequate exhaust must be provided to keep air free of accumulations of flammable vapors</p> <p>Smoking must never be allowed in the spray area.</p> <p>Fire extinguishing equipment must be present in the spray area.</p>
<p><b>Solvent Spray</b></p> 	<p>During cleaning and flushing, solvents can be forcefully expelled from fluid and air passages. Some solvents can cause eye injury.</p>	<p>Wear eye protection.</p>
<p><b>Inhaling Toxic Substances</b></p> 	<p>Certain materials may be harmful if inhaled, or if there is contact with the skin.</p>	<p>Follow the requirements of the Material Safety Data Sheet supplied by your coating material manufacturer.</p> <p>Adequate exhaust must be provided to keep the air free of accumulations of toxic materials.</p> <p>Use a mask or respirator whenever there is a chance of inhaling sprayed materials. The mask must be compatible with the material being sprayed and its concentration. Equipment must be as prescribed by an industrial hygienist or safety expert, and be NIOSH approved.</p>
<p><b>Explosion Hazard – Incompatible Materials</b></p> 	<p>TSC-591 is stainless steel and can be used with Halogenated Hydrocarbons.</p> <p>TLC-576 is aluminum. The solvent 1, 1, 1- Trichloroethane and Methylene Chloride (sometimes called methyl chloride) can chemically react with the aluminum used in most spray equipment, and this cup, to produce an explosion hazard.</p>	<p>Read the label or data sheet for the material you intend to spray.</p> <p>Do not use any type of spray coating material containing these solvents.</p> <p>Do not use these solvents for equipment cleaning or flushing.</p> <p>If in doubt as to whether a material is compatible – contact your material supplier.</p>

**CAUTION**

Do not use abrasives such as a wire brush or steel wool to clean the inside of the Teflon lined cup. Damage to the Teflon surface could result.

**CLEANING**

1. Disconnect spray gun from air supply.
2. Remove cup and empty paint, wipe clean lid, fluid tube and inside cup.
3. Place a small quantity of solvent in the cup. Replace and connect air supply to gun. Spray solvent until clean.
4. Disconnect spray gun from air supply. Remove cup and empty surplus solvent, wipe clean with a lint free dry cloth.
5. Spray solvent into the bottom and side holes of the check valve. Do not direct air pressure higher than 15 psi through or at the check valve. This may damage the valve. The check valve can be removed for cleaning if needed. It cannot be disassembled. Allowing paint to dry on the ball or seat surfaces may cause the check valve not to function properly.
6. Spray solvent into the poppet stem hole. To prevent sticking, it must be cleaned after each use.

**Note**

The cam and mating surfaces on the lid and yoke normally don't require removal for cleaning. Spraying some materials containing Teflon® or similar materials can necessitate more frequent cleaning and possible disassembly of the cam. The overspray containing Teflon® can build up on the cam and mating surfaces causing a condition where the cam may loosen during use.

7. Clean cam and mating surface on lid with a solvent soaked Scotch™ pad and blow dry. If cam loosening persists, removal of the yoke and cam will be required for more thorough cleaning of these parts. Again, use a solvent soaked Scotch™ pad for this purpose. Reassemble lid.

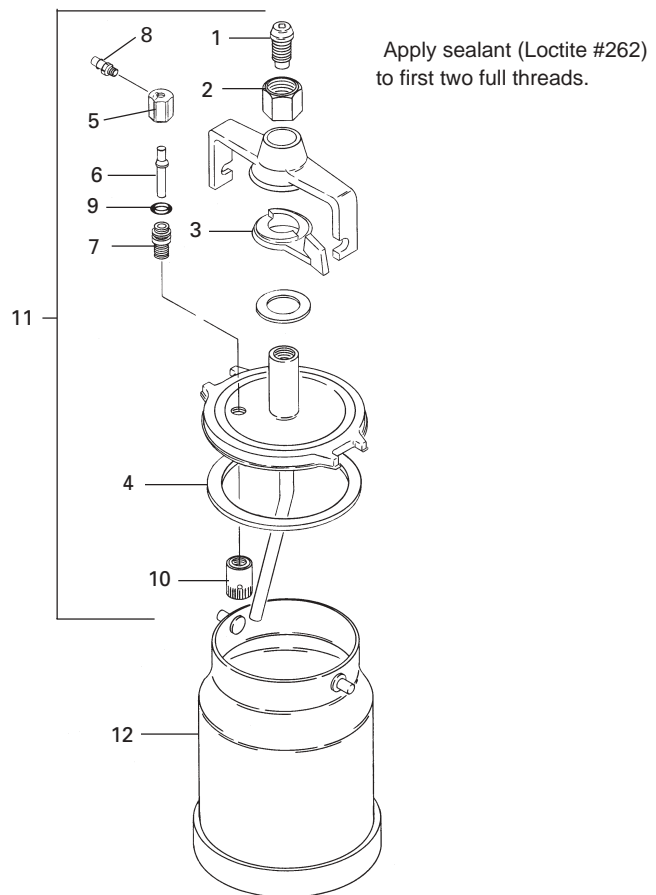

**Figure 1**

**PARTS LIST**

Ref. No.	Replace. Part No.	Description	Ind. Parts Req.
#•1	—	Adapter	1
#•2	—	Nut	1
#•3	—	Cam	1
#•4	TGC-9-K5	**Tri-Seal Gasket	1
*5	—	Air Adapter Body	1
*6	—	Poppet	1
*7	—	Air Adapter Stud	1
*8	—	Straight Barb Fitting	1
*9	—	O Ring	1
*10	TGC-429	Check Valve Assy	1
11	TGC-430	Complete Lid Assy. (For TLC-576, Includes 1-10)	1
	TSC-414	Complete Lid Assy. (For TSC-591, Includes 1-10)	1
12	TLC-401	••Teflon® lined cup (for TLC-576)	1
	TSC-400	Stainless Steel Cup (for TSC-591)	1

- \* KK-4979 Check Valve Poppet Kit includes Ref. Nos. 5-10.
  - KK-5007 Repair Kit for TLC-576 includes Ref. Nos. 1-4.
  - # KK-5008 Repair Kit for TSC-591 includes Ref. Nos. 1-4.
  - Registered Trademark of DuPont
  - \*\* Registered Trademark of Tri-Seal International.
- Repair kits include enough parts to repair one assembly. Suffix -K designates a kit of multiple parts: Example: TGC-9-K5 is a kit of 5 gaskets.

**IMMERSION**

Since all materials in the cup are highly solvent resistant, the cup assembly may be immersed for cleaning. Immersion should not exceed 24 hours. The use of paint strippers should be avoided, because strippers will affect the aluminum as well as other non-metallic components. If the lid gasket has become swollen from prolonged exposure to solvents, it will return to its original size without loss of properties when allowed to dry

**WARRANTY**

This product is covered by DeVilbiss' 1 Year Limited Warranty. See SB-1-000 which is available upon request.

**DeVILBISS WORLDWIDE SALES AND SERVICE LISTING – [www.devilbiss.com](http://www.devilbiss.com)**

**ITW INDUSTRIAL FINISHING**

DeVilbiss has authorized distributors throughout the world. **FOR TECHNICAL ASSISTANCE OR THE DISTRIBUTOR NEAREST YOU, CALL TOLL FREE 1-888-992-4657 (U.S.A. AND CANADA ONLY). FOR LOCAL CALLS, SEE LISTING BELOW.**

U.S./Canada Sales and Customer Service Office  
GLENDALE HEIGHTS, IL 60139

Address  
195 Internationale Blvd.

Telephone  
(630) 237-5000  
Toll Free Fax No. 1-877-790-6965



An Illinois Tool Works Company