

PLEASE FILL OUT THIS PAGE AND RETURN FAX TO UNISORB @ 1-517-764-5607.
THIS DESIGN SERVICE IS FREE. COMPLETE CONTACT INFORMATION IS REQUIRED TO RECEIVE YOUR QUOTE!

CUSTOMER NAME: _____

ADDRESS: _____

PHONE: _____ **FAX:** _____ **E-MAIL:** _____

POINT OF CONTACT: _____

PRESS CHARACTERISTICS

PRESS MAKE: _____ MODEL: _____

PRESS TYPE: OBI OBS S.S. OTHER: _____

PRESS CAPACITY (TONS): _____ PRESS WEIGHT: _____

PRESS SERIAL NUMBER: _____ MAX DIE WEIGHT: _____

PRESS FUNCTION: BLANKING DRAWING EMBOSsing OTHER: _____

BED SIZE: _____ PRESS HEIGHT: _____

FOOT THICKNESS: _____ MAX. TOP WASHER DIA. _____

STROKE LENGTH: _____ STROKES PER MINUTE: _____

WEIGHT DISTRIBUTION: BALANCED UNBALANCED DESCRIBE: _____

MECHANICAL HYDRAULIC PNEUMATIC OTHER: _____

BOLT LENGTH RESTRICTIONS ABOVE FEET? DESCRIBE: _____

OBSTRUCTION BELOW BOTTOM OF PRESS FEET? DESCRIBE: _____

PRESS FEET DIMENSIONS (PLEASE COMPLETE)

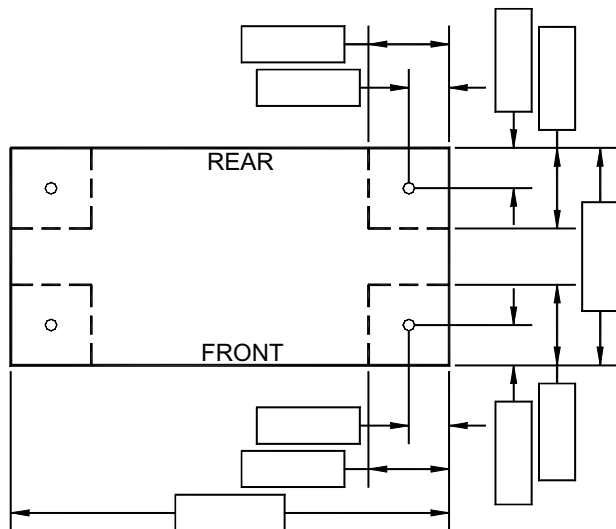

BOLT HOLE SIZE: _____

- ACTUAL
- ESTIMATED

IF PIT IS PRESENT OR REQUIRED,
PLEASE SEND DRAWINGS.

PLEASE QUOTE:

- PRESS MOUNTS
- ANCHORS
- ISOLATION PAD
- GROUT
- ISOLATED FOUNDATION

UNISORB CONTACT INFORMATION

ATTACH CUSTOMER BUSINESS CARD HERE

ATTACH DISTRIBUTOR BUSINESS CARD OR OTHER HERE