

Instructions – Parts List



STAINLESS STEEL

Dura-Flo 900™ Pumps

308354G

With Severe-Duty Rod and Cylinder

U.S. Patent No. 5,456,583
Foreign Patents Pending



Read warnings and instructions.

See page 2 for model numbers and maximum working pressures.

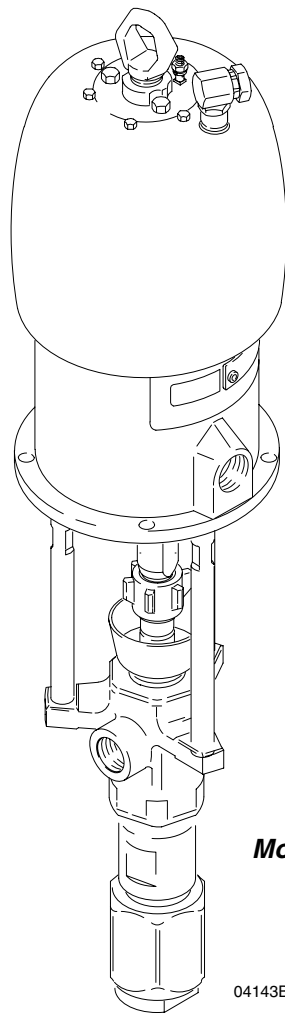

Model 237287

04143B

Model 237286

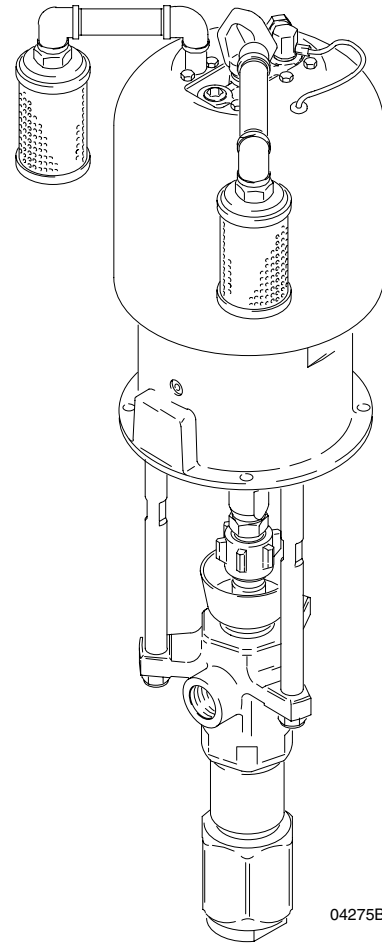

04275B

PROVEN QUALITY. LEADING TECHNOLOGY.



List of Models

Pump Part No. and Series	Pump Model	Ratio	Maximum Fluid Working Pressure	Maximum Air/Hydraulic Input Pressure
237286, Series B	Reduced Icing Quiet King™	56:1	38.6 MPa, 386 bar (5600 psi)	0.7 MPa, 7 bar (100 psi)
237287, Series A	Bulldog®	28:1	19.3 MPa, 193 bar (2800 psi)	0.7 MPa, 7 bar (100 psi)
237280, Series A	Senator®	17:1	11.7 MPa, 117 bar (1700 psi)	0.7 MPa, 7 bar (100 psi)
245172, Series A	King™	56:1	38.6 MPa, 386 bar (5600 psi)	0.7 MPa, 7 bar (100 psi)
245173, Series B	Quiet King™	56:1	38.6 MPa, 386 bar (5600 psi)	0.7 MPa, 7 bar (100 psi)
237290, Series A	Viscount® II (hydraulic)	3.5:1	34 MPa, 345 bar (5000 psi)	9.9 MPa, 99 bar (1428 psi) hydraulic pressure
248817, Series A	Viscount® II (hydraulic)	3.5:1	34 MPa, 345 bar (5000 psi)	9.9 MPa, 99 bar (1428 psi) hydraulic pressure

Table of Contents

Warnings	3
Installation	6
Operation/Maintenance	10
Troubleshooting Chart	15
Service	16
Required Tools	16
Disconnecting the Displacement Pump	16
Reconnecting the Displacement Pump	16
Displacement Pump Service	18
Parts Drawings and Parts Lists	22
Pump Assemblies	22
Displacement Pump	26
Technical Data	28
Dimensions	33
Mounting Hole Layout	33
Warranty	34
Graco Information	34

Symbols

Warning Symbol



This symbol alerts you to the possibility of serious injury or death if you do not follow the instructions.

Caution Symbol



This symbol alerts you to the possibility of damage to or destruction of equipment if you do not follow the instructions.

WARNING



INSTRUCTIONS

EQUIPMENT MISUSE HAZARD

Equipment misuse can cause the equipment to rupture or malfunction and result in serious injury.

- This equipment is for professional use only.
- Read all instruction manuals, tags, and labels before operating the equipment.
- Use the equipment only for its intended purpose. If you are not sure, contact your Graco distributor.
- Do not alter or modify this equipment.
- Check equipment daily. Repair or replace worn or damaged parts immediately.
- Do not exceed the maximum working pressure of the lowest rated system component. Refer to the **Technical Data** on pages 28–30 for the maximum working pressure of this equipment.
- Use fluids and solvents which are compatible with the equipment wetted parts. Refer to the **Technical Data** section of all equipment manuals. Read the fluid and solvent manufacturer's warnings.
- Do not use hoses to pull equipment.
- Route hoses away from traffic areas, sharp edges, moving parts, and hot surfaces. Do not expose Graco hoses to temperatures above 82°C (180°F) or below –40°C (–40°F).
- Wear hearing protection when operating this equipment.
- Do not lift pressurized equipment.
- Comply with all applicable local, state, and national fire, electrical, and safety regulations.

WARNING

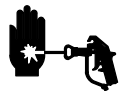

INJECTION HAZARD

Spray from the gun, leaks or ruptured components can inject fluid into your body and cause extremely serious injury, including the need for amputation. Fluid splashed in the eyes or on the skin can also cause serious injury.



- Fluid injected into the skin might look like just a cut, but it is a serious injury. **Get immediate medical attention.**
- Do not point the gun at anyone or at any part of the body.
- Do not put your hand or fingers over the spray tip.
- Do not stop or deflect leaks with your hand, body, glove or rag.
- Do not “blow back” fluid; this is not an air spray system.
- Always have the tip guard and the trigger guard on the gun when spraying.
- Check the gun diffuser operation weekly. Refer to the gun manual.
- Be sure the gun trigger safety operates before spraying.
- Lock the gun trigger safety when you stop spraying.
- Follow the **Pressure Relief Procedure** on page 10 if the spray tip clogs and before cleaning, checking or servicing the equipment.
- Tighten all fluid connections before operating the equipment.
- Check the hoses, tubes, and couplings daily. Replace worn or damaged parts immediately. Do not repair high pressure couplings; you must replace the entire hose.
- Fluid hoses must have spring guards on both ends, to help protect them from rupture caused by kinks or bends near the couplings.



MOVING PARTS HAZARD

Moving parts, such as the air motor piston, can pinch or amputate your fingers.

- Keep clear of all moving parts when starting or operating the pump.
- Before servicing the equipment, follow the **Pressure Relief Procedure** on page 10 to prevent the equipment from starting unexpectedly.

WARNING



FIRE AND EXPLOSION HAZARD

Improper grounding, poor ventilation, open flames or sparks can cause a hazardous condition and result in a fire or explosion and serious injury.



- Ground the equipment and the object being sprayed. Refer to **Grounding** on page 6.
- If there is any static sparking or you feel an electric shock while using this equipment, **stop spraying immediately**. Do not use the equipment until you identify and correct the problem.
- Provide fresh air ventilation to avoid the buildup of flammable fumes from solvents or the fluid being sprayed.
- Keep the spray area free of debris, including solvent, rags, and gasoline.
- Electrically disconnect all equipment in the spray area.
- Extinguish all open flames or pilot lights in the spray area.
- Do not smoke in the spray area.
- Do not turn on or off any light switch in the spray area while operating or if fumes are present.
- Do not operate a gasoline engine in the spray area.



TOXIC FLUID HAZARD

Hazardous fluid or toxic fumes can cause serious injury or death if splashed in the eyes or on the skin, inhaled, or swallowed.

- Know the specific hazards of the fluid you are using.
- Store hazardous fluid in an approved container. Dispose of hazardous fluid according to all local, state and national guidelines.
- Always wear protective eyewear, gloves, clothing and respirator as recommended by the fluid and solvent manufacturer.

Installation

General Information

NOTE: Reference numbers and letters in parentheses in the text refer to the callouts in the figures and the parts drawing.

NOTE: Always use Genuine Graco Parts and Accessories, available from your Graco distributor. Refer to Product Data Sheet, Form No. 305715 (Senator Pumps), Form No. 305716 (Bulldog Pumps), and Form No. 305717 (King Pumps). If you supply your own accessories, be sure they are adequately sized and pressure rated for your system.

Grounding

⚠ WARNING

FIRE AND EXPLOSION HAZARD
Before operating the pump, ground the system as explained below. Also read the section **FIRE OR EXPLOSION HAZARD** on page 5.

1. *King Pumps:* use a ground wire and clamp. See Fig. 1. Remove the ground screw (Z) and insert through eye of ring terminal at the end of ground wire (Y). Fasten ground screw back onto pump and tighten securely. Connect the other end of ground wire to a true earth ground. Order Part No. 222011 Ground Wire and Clamp.

All Other Pumps: use a ground wire and clamp. See Fig. 2. Loosen the grounding lug locknut (W) and washer (X). Insert one end of a 1.5 mm² (12 ga) minimum ground wire (Y) into the slot in lug (Z) and tighten the locknut securely. Connect the other end of the wire to a true earth ground. Order Part No. 237569 Ground Wire and Clamp.

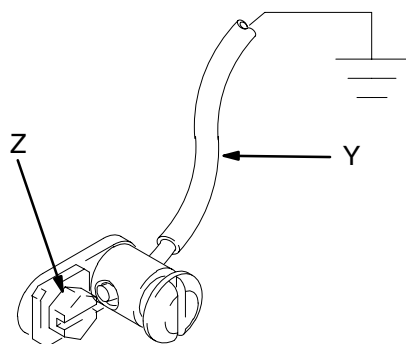
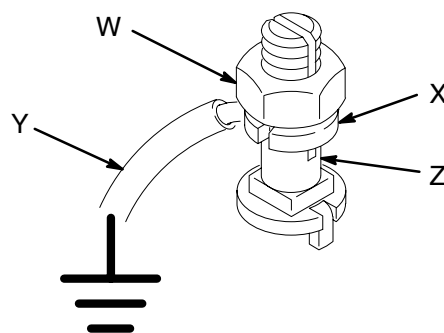

Fig. 1

T11052



0864

Fig. 2

2. *Air and fluid hoses:* use only electrically conductive hoses.
3. *Air compressor:* follow manufacturer's recommendations.
4. *Spray gun:* ground through connection to a properly grounded fluid hose and pump.
5. *Fluid supply container:* follow your local code.
6. *Object being sprayed:* follow your local code.
7. *Solvent pails used when flushing:* follow your local code. Use only metal pails, which are conductive, placed on a grounded surface. Do not place the pail on a nonconductive surface, such as paper or cardboard, which interrupts the grounding continuity.
8. *To maintain grounding continuity when flushing or relieving pressure,* hold a metal part of the spray gun firmly to the side of a grounded *metal* pail, then trigger the gun.

System Accessories

Fig. 3 is only a guide for selecting and installing system components and accessories. Contact your Graco distributor for assistance in designing a system to suit your particular needs.

Air and Fluid Hoses

Be sure all air hoses (H) and fluid hoses (N and P) are properly sized and pressure-rated for your system. Use only electrically conductive hoses. Fluid hoses must have spring guards on both ends. Use a whip hose (P) and a swivel (R) between the main fluid hose (N) and the gun (S) to allow freer gun movement.

Mounting Accessories

Mount the pump (A) to suit the type of installation planned. Fig. 3 illustrates a wall mount system. Pump dimensions and the mounting hole layout are shown on page 33.

If you are using a floor stand, refer to its separate manual for installation and operation instructions.

Installation

System Accessories (continued)

WARNING

A bleed-type master air valve (E) and a fluid drain valve (M) are required in your system. These accessories help reduce the risk of serious injury, including fluid injection and splashing of fluid in the eyes or on the skin, and injury from moving parts if you are adjusting or repairing the pump.

The bleed-type master air valve relieves air trapped between this valve and the pump after the air is shut off. Trapped air can cause the pump to cycle unexpectedly. Locate the valve close to the pump. Order Part No. 107141.

A fluid drain valve (M) helps reduce the risk of serious bodily injury, including fluid injection and splashing of fluid in the eyes or on the skin, and injury from moving parts if you are adjusting or repairing the pump.

The fluid drain valve assists in relieving fluid pressure in the displacement pump, hose, and gun. Triggering the gun to relieve pressure may not be sufficient. Order Part No. 210658.

Air Line Accessories

Install the following accessories in the locations shown in Fig. 3, using adapters as necessary:

- **An air line lubricator (D)** provides automatic air motor lubrication.
- **A bleed-type master air valve (E)** is required in your system to relieve air trapped between it and the air motor when the valve is closed (see the **WARNING** above). Be sure the bleed valve is easily accessible from the pump, and is located **downstream** from the air regulator.
- **An air regulator (F)** controls pump speed and outlet pressure by adjusting the air pressure to the pump. Locate the regulator close to the pump, but **upstream** from the bleed-type master air valve.

- **A pump runaway valve (C)** senses when the pump is running too fast and automatically shuts off the air to the motor. A pump which runs too fast can be seriously damaged.
- **An air manifold (G)** has a 3/4 npsm(f) swivel air inlet. It mounts to the pump support bracket, and provides ports for connecting lines to air-powered accessories.
- **An air line filter (J)** removes harmful dirt and moisture from the compressed air supply. Also, install a **drain valve (W)** at the bottom of each air line drop, to drain off moisture.
- **A second bleed-type air valve (K)** isolates the air line accessories for servicing. Locate upstream from all other air line accessories.

Fluid Line Accessories

Install the following accessories in the locations shown in Fig. 3, using adapters as necessary:

- **A fluid filter (L)** with a 60 mesh (250 micron) stainless steel element, to filter particles from the fluid as it leaves the pump.
- **A fluid drain valve (M)**, which is required in your system, helps relieve fluid pressure in the hose and gun (see the **WARNING** at left).
- **A gun (S)** dispenses the fluid. The gun shown in Fig. 3 is an airless spray gun for light to medium viscosity fluids.
- **A gun swivel (R)** allows freer gun movement.
- **A suction kit (T)** allows the pump to draw fluid from a supply container.

CAUTION

To prevent intake valve damage, always apply PTFE tape to the female threads of the intake valve before connecting a suction hose or fitting to the intake.

Installation

TYPICAL INSTALLATION

KEY

- | | | |
|---|--|---|
| A Pump | H Electrically Conductive Air Supply Hose | P Fluid Whip Hose |
| B Wall Bracket | J Air Line Filter | R Gun Swivel |
| C Pump Runaway Valve | K Bleed-Type Master Air Valve (for accessories) | S Airless Spray Gun |
| D Air Line Lubricator | L Fluid Filter | T Suction Kit |
| E Bleed-Type Master Air Valve (required, for pump) | M Fluid Drain Valve (required) | Y Ground Wire and Clamp (required; see page 6 for installation instructions) |
| F Pump Air Regulator | N Electrically Conductive Fluid Supply Hose | W Air Line Drain Valve |
| G Air Manifold | | |

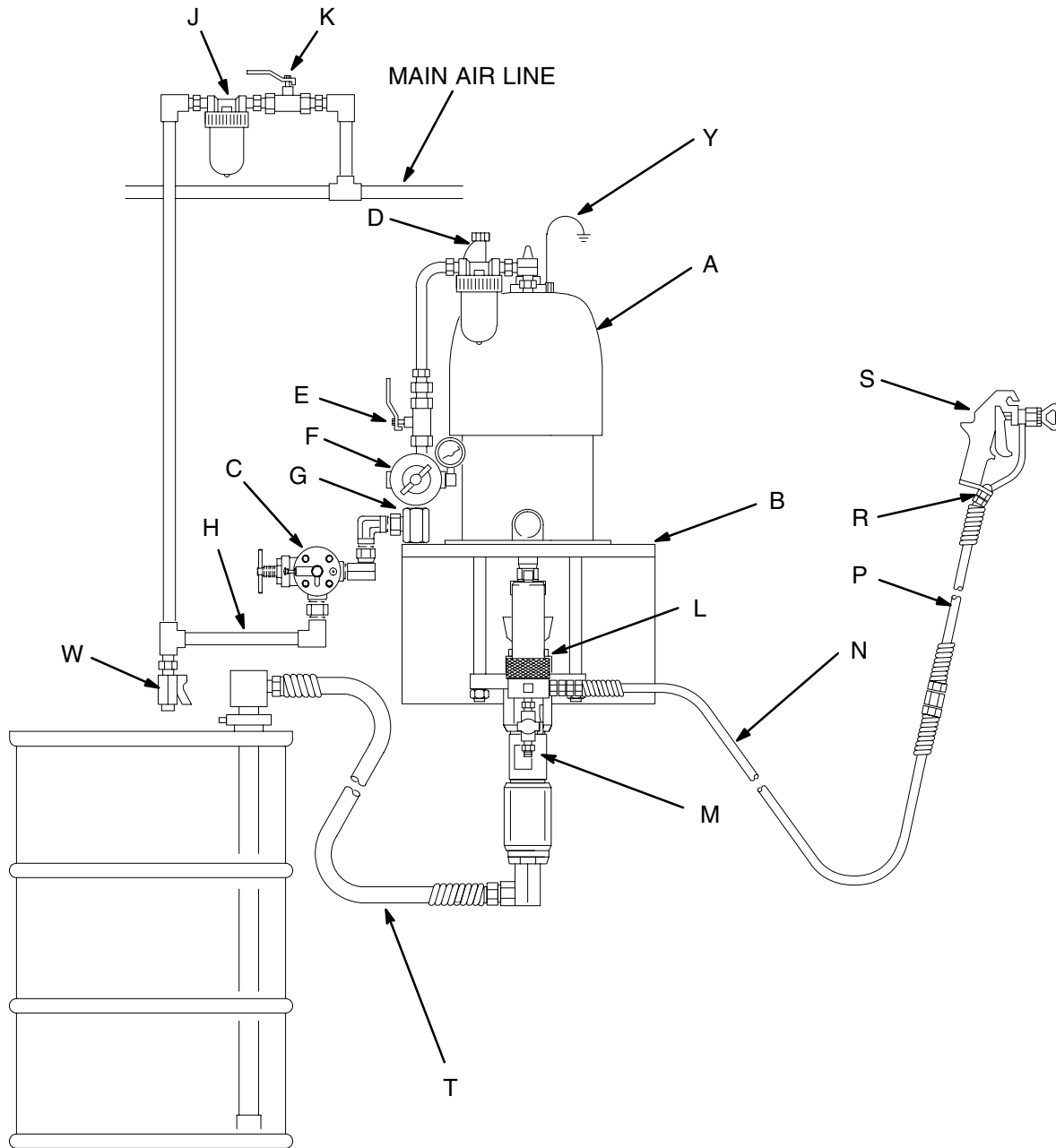

Fig. 3

04177B

Installation

(HYDRAULIC-POWERED PUMPS)

Fluid Line Accessories

Install the following accessories in the locations shown in Fig. 4, using adapters as necessary:

- **A fluid filter (L)** with a 60 mesh (250 micron) stainless steel element, to filter particles from the fluid as it leaves the pump.
- **A fluid drain valve (M)**, which is required in your system, helps relieve fluid pressure in the hose and gun (see the **WARNING** on page 7).
- **A gun (S)** dispenses the fluid. The gun shown in Fig. 4 is an airless spray gun for light to medium viscosity fluids.
- **A gun swivel (R)** allows freer gun movement.
- **A suction kit (T)** allows the pump to draw fluid from a supply container.

KEY

- A Pump
- B Wall Bracket
- C Hydraulic Supply Line
- D Hydraulic Return Line
- E Drain Line (from pressure reducing valve)
- F Pressure Gauge
- G Flow Control Valve
- H Pressure Reducing Valve
- J Accumulator
- K Drain Line (from motor drip pan)
- L Fluid Filter
- M Fluid Drain Valve (required)
- N Electrically Conductive Fluid Supply Hose
- P Fluid Whip Hose
- R Gun Swivel
- S Airless Spray Gun
- T Drum Suction Kit
- U Hydraulic Supply Line Shutoff Valve
- V Hydraulic Return Line Shutoff Valve
- Y Ground Wire (required, see page 6 for installation instructions)
- AA Hydraulic Return Line Filter

TYPICAL HYDRAULIC-POWERED INSTALLATION

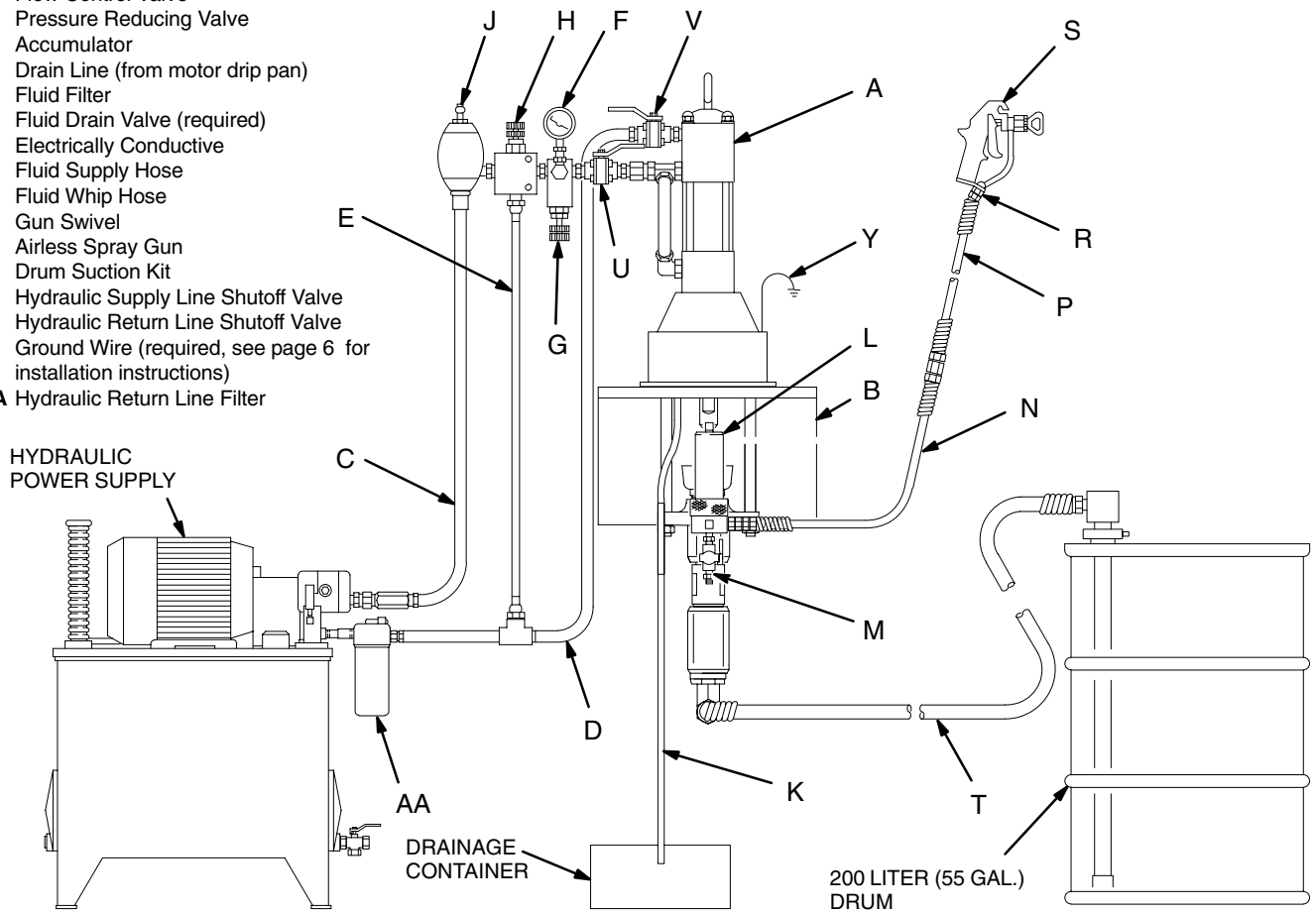

Fig. 4

04582B

Operation/Maintenance

Pressure Relief Procedure

WARNING

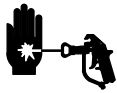

INJECTION HAZARD

The system pressure must be manually relieved to prevent the system from starting or spraying accidentally. Fluid under high pressure can be injected through the skin and cause serious injury. To reduce the risk of an injury from injection, splashing fluid, or moving parts, follow the **Pressure Relief Procedure** whenever you:

- are instructed to relieve the pressure,
- stop spraying,
- check or service any of the system equipment,
- or install or clean the spray tips.

1. Lock the gun/valve trigger safety.
2. Shut off the air supply to the pump.
3. Close the bleed-type master air valve (required in your system).
4. Unlock the gun/valve trigger safety.
5. Hold a metal part of the gun firmly to the side of a grounded metal pail, and trigger the gun to relieve pressure.
6. Lock the gun/valve trigger safety.
7. Open the drain valve (required in your system), having a container ready to catch the drainage.
8. Leave the drain valve open until you are ready to spray again.

If you suspect that the spray tip or hose is completely clogged, or that pressure has not been fully relieved after following the steps above, very slowly loosen the tip guard retaining nut or hose end coupling and relieve pressure gradually, then loosen completely. Now clear the tip or hose.

Packing Nut/Wet-Cup

Before starting, fill the packing nut (2) 1/3 full with Graco Throat Seal Liquid (TSL) or compatible solvent. See Fig. 5.

WARNING

To reduce the risk of serious injury whenever you are instructed to relieve pressure, always follow the **Pressure Relief Procedure** at left.

The packing nut is torqued at the factory and is ready for operation. If it becomes loose and there is leaking from the throat packings, **relieve the pressure**, then torque the nut to 136–149 N.m (100–110 ft-lb) using the supplied wrench (110). Do this whenever necessary. Do not overtighten the packing nut.

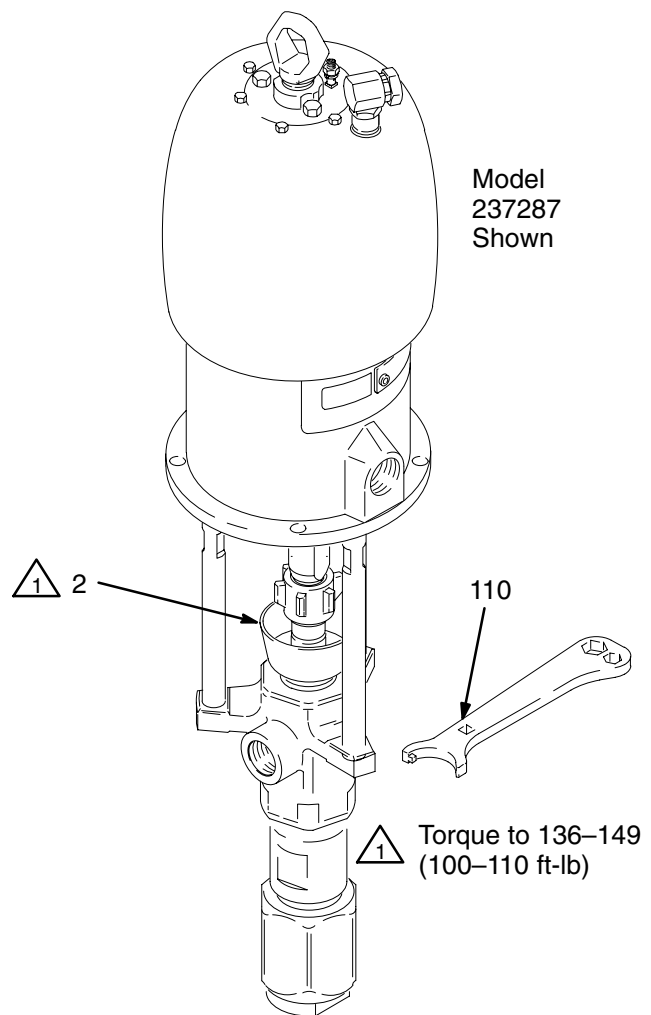

Fig. 5

04143B

Operation/Maintenance

Flush the Pump Before First Use

The pump is tested with lightweight oil, which is left in to protect the pump parts. If the fluid you are using may be contaminated by the oil, flush it out with a compatible solvent. See **Flushing** on page 12.

Starting and Adjusting the Pump

1. See Fig. 3. Connect the suction kit (T) to the pump's fluid inlet. Place the tube into the fluid supply.

CAUTION

To prevent intake valve damage, always apply PTFE tape to the female threads of the intake valve before connecting a suction hose or fitting to the intake.

2. Close the air regulator (F).
3. Open the pump's bleed-type master air valve (E).
4. Hold a metal part of the gun (S) firmly to the side of a grounded metal pail and hold the trigger open.
5. Slowly open the regulator until the pump starts.
6. Cycle the pump slowly until all air is pushed out and the pump and hoses are fully primed.
7. Release the gun trigger and lock the trigger safety. The pump should stall against pressure.
8. If the pump fails to prime properly, open the drain valve (M). Use the drain valve as a priming valve until the fluid flows from the valve. Close the valve.

NOTE: When changing fluid containers with the hose and gun already primed, open the drain valve (M) to help prime the pump and vent air before it enters the hose. Close the drain valve when all air is eliminated.

CAUTION

Do not allow the pump to run dry. It will quickly accelerate to a high speed, causing damage. If your pump is running too fast, stop it immediately and check the fluid supply. If the container is empty and air has been pumped into the lines, refill the container and prime the pump and the lines, or flush and leave it filled with a compatible solvent. Eliminate all air from the fluid system.

9. With the pump and lines primed, and with adequate air pressure and volume supplied, the pump will start and stop as you open and close the gun. In a circulating system, the pump will speed up or slow down on demand, until the air supply is shut off.

WARNING

COMPONENT RUPTURE HAZARD



To reduce the risk of overpressurizing your system, which could cause component rupture and serious injury, *never exceed the specified Maximum Incoming Air Pressure to the pump* (see the **Technical Data**, on pages 28–30).

10. Use the air regulator (F) to control pump speed and fluid pressure. Always use the lowest air pressure necessary to get the desired results. Higher pressures cause premature tip and pump wear.

Operation/Maintenance

Shutdown and Care of the Pump

WARNING

To reduce the risk of serious injury whenever you are instructed to relieve pressure, always follow the **Pressure Relief Procedure** on page 10.

For overnight shutdown, stop the pump at the bottom of its stroke to prevent fluid from drying on the exposed displacement rod and damaging the throat packings. **Relieve the pressure.**

Always flush the pump before the fluid dries on the displacement rod. See **Flushing** below.

Flushing

WARNING



FIRE AND EXPLOSION HAZARD

Before flushing, read the section **FIRE OR EXPLOSION HAZARD** on page 5.

Be sure the entire system and flushing pails are properly grounded. Refer to **Grounding** on page 6.



Flush with a fluid that is compatible with the fluid you are pumping and with the wetted parts in your system. Check with your fluid manufacturer or supplier for recommended flushing fluids and flushing frequency. Always flush the pump before fluid dries on the displacement rod.

WARNING

To reduce the risk of serious injury whenever you are instructed to relieve pressure, always follow the **Pressure Relief Procedure** on page 10.

1. **Relieve the pressure.**
2. Remove the spray tip from the gun.
3. Hold a metal part of the gun firmly to the side of a grounded *metal* pail.
4. Start the pump. Always use the lowest possible fluid pressure when flushing.
5. Trigger the gun.
6. Flush the system until clear solvent flows from the gun.
7. **Relieve the pressure.**

Operation/Maintenance

(HYDRAULIC-POWERED PUMPS)

Flush the Pump Before First Use

The pump is tested with lightweight oil, which is left in to protect the pump parts. If the fluid you are using may be contaminated by the oil, flush it out with a compatible solvent. See **Flushing** on page 14.

Starting and Adjusting the Pump

1. Refer to Fig. 4 on page 9. Connect the suction kit (T) to the pump's fluid inlet, and place the tube into the fluid supply.
2. Check the hydraulic fluid level before each use, and add fluid as necessary.
3. Make certain that the supply line shutoff valve (U) and the return line shutoff valve (V) are closed.
4. Start the hydraulic power supply.
5. Hold a metal part of the gun (S) firmly to the side of a grounded metal pail and hold the trigger open.
6. Open the return line shutoff valve (V) *first*, then slowly open the supply line shutoff valve (U).
7. Cycle the pump slowly until all air is pushed out and the pump and hoses are fully primed.
8. Release the gun trigger and lock the trigger safety. The pump should stall against pressure.
9. If the pump fails to prime properly, open the drain valve (M). Use the drain valve as a priming valve until the fluid flows from the valve. Close the valve.
10. With the pump and lines primed, and with adequate hydraulic volume supplied, the pump will start and stop as you open and close the gun. In a circulating system, the pump will speed up or slow down on demand, until the hydraulic power supply is shut off.
11. Use the fluid pressure gauge (F) and flow control valve (G) to control the pump speed and the fluid outlet pressure. Always use the lowest hydraulic flow and pressure necessary to get the desired results. Higher pressures cause premature tip/nozzle and pump wear.

NOTE: When changing fluid containers with the hose and gun already primed, open the drain valve (M) to help prime the pump and vent air before it enters the hose. Close the drain valve when all air is eliminated.

WARNING

COMPONENT RUPTURE HAZARD



To reduce the risk of overpressurizing your system, which could cause component rupture and serious injury, *never exceed the specified Maximum Incoming Air Pressure to the pump* (see the **Technical Data** on page 31).

To prevent overpressurizing the hydraulic motor or its seals, always shut off the supply line valve (U) *first*, then shut off the return line valve (V).

CAUTION

Do not allow the hydraulic oil temperature to exceed 54°C (130°F). The pump seals will wear faster and leakage may occur if the pump is operated at higher oil temperatures.

Operation/Maintenance

(HYDRAULIC-POWERED PUMPS)

Shutdown and Care of the Pump

WARNING

To reduce the risk of serious injury whenever you are instructed to relieve pressure, always follow the **Pressure Relief Procedure** on page 10.

For overnight shutdown, stop the pump at the bottom of its stroke to prevent fluid from drying on the exposed displacement rod and damaging the throat packings. **Relieve the pressure.**

Always flush the pump before the fluid dries on the displacement rod. See **Flushing** below.

Flushing

WARNING



FIRE AND EXPLOSION HAZARD

Before flushing, read the section **FIRE AND EXPLOSION HAZARD** on page 5. Be sure the entire system and flushing pails are properly grounded. Refer to **Grounding** on page 6.

Flush with a fluid that is compatible with the fluid you are pumping and with the wetted parts in your system. Check with your fluid manufacturer or supplier for recommended flushing fluids and flushing frequency. Always flush the pump before fluid dries on the displacement rod.

CAUTION

Never leave water or water-base fluid in the pump overnight. If you are pumping water-base fluid, flush with water first, then with a rust inhibitor such as mineral spirits. Relieve the pressure, but leave the rust inhibitor in the pump to protect the parts from corrosion.

WARNING

To reduce the risk of serious injury whenever you are instructed to relieve pressure, always follow the **Pressure Relief Procedure** on page 10.

1. **Relieve the pressure.**
2. Remove the spray tip from the gun.
3. Hold a metal part of the gun firmly to the side of a grounded *metal* pail.
4. Start the pump. Always use the lowest possible fluid pressure when flushing.
5. Trigger the gun.
6. Flush the system until clear solvent flows from the gun.
7. **Relieve the pressure.**

Troubleshooting Chart

WARNING

To reduce the risk of serious injury whenever you are instructed to relieve pressure, always follow the **Pressure Relief Procedure** on page 10.

1. **Relieve the pressure.**
2. Check all possible causes and problems before disassembling the pump.

PROBLEM	CAUSE	SOLUTION
The pump fails to operate.	Restricted air/hydraulic line or an inadequate air/hydraulic supply; closed or clogged valves.	Clear the line; increase the air/hydraulic supply. Check that the valves are open.
	Obstructed fluid hose or gun; the fluid hose ID is too small.	Open, clear*; use a hose with a larger ID.
	Fluid has dried on the displacement rod.	Clean the rod; always stop the pump at the bottom of its stroke; keep the wet-cup 1/3 filled with a compatible solvent.
	Dirty, worn, or damaged motor parts.	Clean or repair; see the separate motor manual.
The pump operates, but the output is low on both strokes.	Restricted air/hydraulic line or an inadequate air/hydraulic supply; closed or clogged valves.	Clear the line; increase the air/hydraulic supply. Check that the valves are open.
	Obstructed fluid hose or gun; the fluid hose ID is too small.	Open, clear*; use a hose with a larger ID.
	Worn packings in the displacement pump.	Replace the packings.
The pump operates, but the output is low on the downstroke.	Held open or worn intake valve.	Clear the valve; service.
The pump operates, but the output is low on the upstroke.	Held open or worn piston valve or packings.	Clear the valve; replace the packings.
Erratic or accelerated pump speed.	Exhausted fluid supply.	Refill the supply and prime the pump.
	Held open or worn piston valve or packings.	Clear the valve; replace the packings.
	Held open or worn intake valve.	Clear the valve; service.

* To determine if the fluid hose or gun is obstructed, follow the **Pressure Relief Procedure** on page 10. Disconnect the fluid hose and place a container at the pump fluid outlet to catch any fluid. Turn on the air or hydraulic power just enough to start the pump. If the pump starts when the air or hydraulic power is turned on, the obstruction is in the fluid hose or gun.

NOTE: If you experience air motor icing, call your Graco distributor.

Service

Required Tools

- Set of adjustable wrenches
- Large pipe wrench
- Torque wrench
- Rubber mallet
- O-ring pick
- Large vise
- Thread lubricant
- Thread sealant

Disconnecting the Displacement Pump

1. Flush the pump, if possible. Stop the pump at the bottom of its stroke.

WARNING

To reduce the risk of serious injury whenever you are instructed to relieve pressure, always follow the **Pressure Relief Procedure** on page 10.

2. **Relieve the pressure.**
3. Disconnect the air hose and the fluid hose.
4. Disconnect the displacement pump (109) from the motor (101) as follows. Note the relative position of the pump's fluid outlet (U) to the air inlet (V) of the motor. If the motor does not require servicing, leave it attached to its mounting.

CAUTION

Be sure to use *at least* two people when lifting, moving, or disconnecting the pump. This pump is too heavy for one person. If you are disconnecting the displacement pump from a motor which is still mounted (for example, on a wall bracket), *be sure* to support the displacement pump while it is being disconnected, to prevent it from falling and causing injury or property damage. Do this by securely bracing the pump, or by having at least two people hold it while another disconnects it.

If the pump is mounted on a cart, slowly tip the cart backward until the handle rests on the ground, then disconnect the displacement pump.

5. Using an adjustable wrench (or hammer and punch), unscrew the coupling nut (106) from the motor shaft (W). Do not lose or drop the coupling collars (107). See Fig. 6.
6. Hold the tie rod flats with a wrench to keep the rods from turning. Unscrew the nuts (108) from the tie rods (105). Carefully remove the displacement pump (109) from the motor (101).
7. Refer to page 18 for displacement pump service. To service the air motor, refer to the separate motor manual, supplied.

Reconnecting the Displacement Pump

1. Make sure the coupling nut (106) and the coupling collars (107) are in place on the displacement rod (1). See Fig. 6.
2. Use at least two people to hold the displacement pump while another reconnects it to the motor (see the **CAUTION** at left). Orient the pump's fluid outlet (U) to the air inlet (V) as was noted in step 4 under **Disconnecting the Displacement Pump**. Position the displacement pump (109) on the tie rods (105).
3. Screw the nuts (108) onto the tie rods (105) and torque to 81–89 N.m (60–66 ft-lb).
4. Screw the coupling nut onto the motor shaft (W) loosely. Hold the motor shaft flats with a wrench to keep it from turning. Use an adjustable wrench to tighten the coupling nut. Torque to 196–210 N.m (145–155 ft-lb).
5. Reconnect all hoses. Reconnect the ground wire if it was disconnected. Fill the packing nut (2) 1/3 full of Graco Throat Seal Liquid or compatible solvent.
6. Turn on the air supply. Run the pump slowly to ensure proper operation.

WARNING

To reduce the risk of serious injury whenever you are instructed to relieve pressure, always follow the **Pressure Relief Procedure** on page 10.

7. Before returning the pump to production, **relieve the pressure** and retorque the packing nut (2) to 136–149 N.m (100–110 ft-lb).

Service

Model 237287 Shown

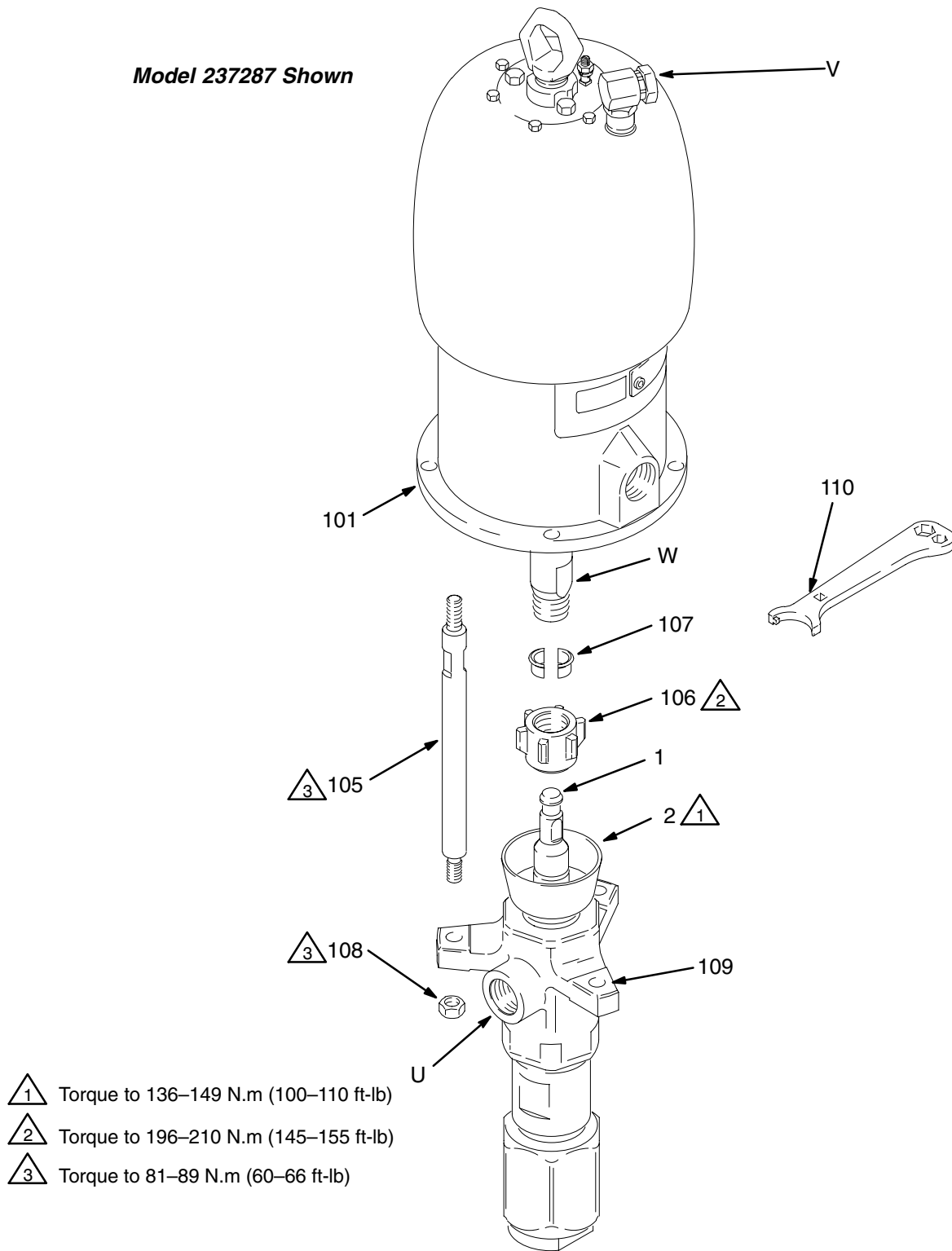

- △1 Torque to 136–149 N.m (100–110 ft-lb)
- △2 Torque to 196–210 N.m (145–155 ft-lb)
- △3 Torque to 81–89 N.m (60–66 ft-lb)

Fig. 6

04142B

Service

DISPLACEMENT PUMP SERVICE

Disassembly

When disassembling the pump, lay out all the removed parts in sequence, to ease reassembly.

NOTE: Packing Repair Kits are available. For the best results, use all the new parts in the kit. Kit parts are marked with an asterisk, for example (3*). You can also convert the pump to different packing materials. Refer to page 27.

1. Place the pump lengthwise in a large vise, with the jaws on either the outlet housing (7) as shown in Fig. 7 or on the cylinder (9) flats. Using the supplied wrench (110), loosen, but do not remove, the packing nut (2).
2. Apply a pipe wrench to the flats of the intake valve (19). Unscrew the intake valve (19) from the intake housing (18). Be careful to catch the intake ball (17) as you remove the intake valve, so that it does not fall and suffer damage. Remove the seal (8) from the intake valve. Inspect the ball and the seat (D) of the intake valve for wear or damage.
3. Apply a pipe wrench to the hex of the valve housing (18). The pump assembly may separate at joint A or joint B.

CAUTION

To reduce the possibility of costly damage to the rod (1) and cylinder (9), *always* use a rubber mallet to drive the rod out of the cylinder. *Never* use a hammer.

- **If the assembly separates at joint A:**

- a. Unscrew the valve housing (18) from the cylinder, using a 2–5/8 in. wrench for the cylinder flats. Using a rubber mallet, drive the displacement rod (1) and piston assembly out of the outlet housing (7) and cylinder (9) until the piston comes free. Pull the rod and piston from the cylinder, being careful not to scratch the parts.
- b. Using a 2–5/8 in. wrench for the cylinder flats, unscrew the cylinder (9) from the outlet housing (7). Remove the two seals (8) from the cylinder. Shine a light into the cylinder (9) to inspect the inner surface for scoring or wear. Now go to step 4.

- **If the assembly separates at joint B:**

- c. Unscrew the cylinder (9) and valve housing (18) from the outlet housing (7). Gently pull the cylinder and valve housing straight out of the outlet housing; the displacement rod (1) and piston assembly will come out with these parts.
 - d. Place the valve housing (18) in the vise and unscrew the cylinder (9) from the housing, using a 2–5/8 in. wrench for the cylinder flats. The displacement rod (1) and piston assembly will remain in the cylinder.
 - e. Using a rubber mallet, drive the displacement rod (1) and piston assembly out of the cylinder (9) until the piston comes free. Pull the rod and piston from the cylinder, being careful not to scratch the parts.
 - f. Remove the two seals (8) from the cylinder. Shine a light into the cylinder (9) to inspect the inner surface for scoring or wear. Now go to step 4.
4. Place the flats of the piston seat housing (16) in a vise, as shown in Fig. 8.
 5. Using an adjustable wrench, unscrew the piston ball housing (10) from the piston seat housing. Be careful to catch the piston ball (11) as you separate the piston seat housing and ball housing, so that it does not fall and suffer damage.
 6. Examine the displacement rod (1) for scratches or other damage. **Only if the rod needs replacement**, unscrew it from the piston ball housing (10), using an adjustable wrench on the flats of the rod.
 7. Remove the glands and v-packings (P) from the piston seat housing (16). Inspect the ball (11), and the seat (E) and guides (F) on the housing for wear or damage. See Fig. 9.
 8. Unscrew the packing nut (2) from the outlet housing (7). Remove the glands and v-packings (T). See Fig. 9.
 9. Clean all parts with a compatible solvent and inspect them for wear or damage.

Service

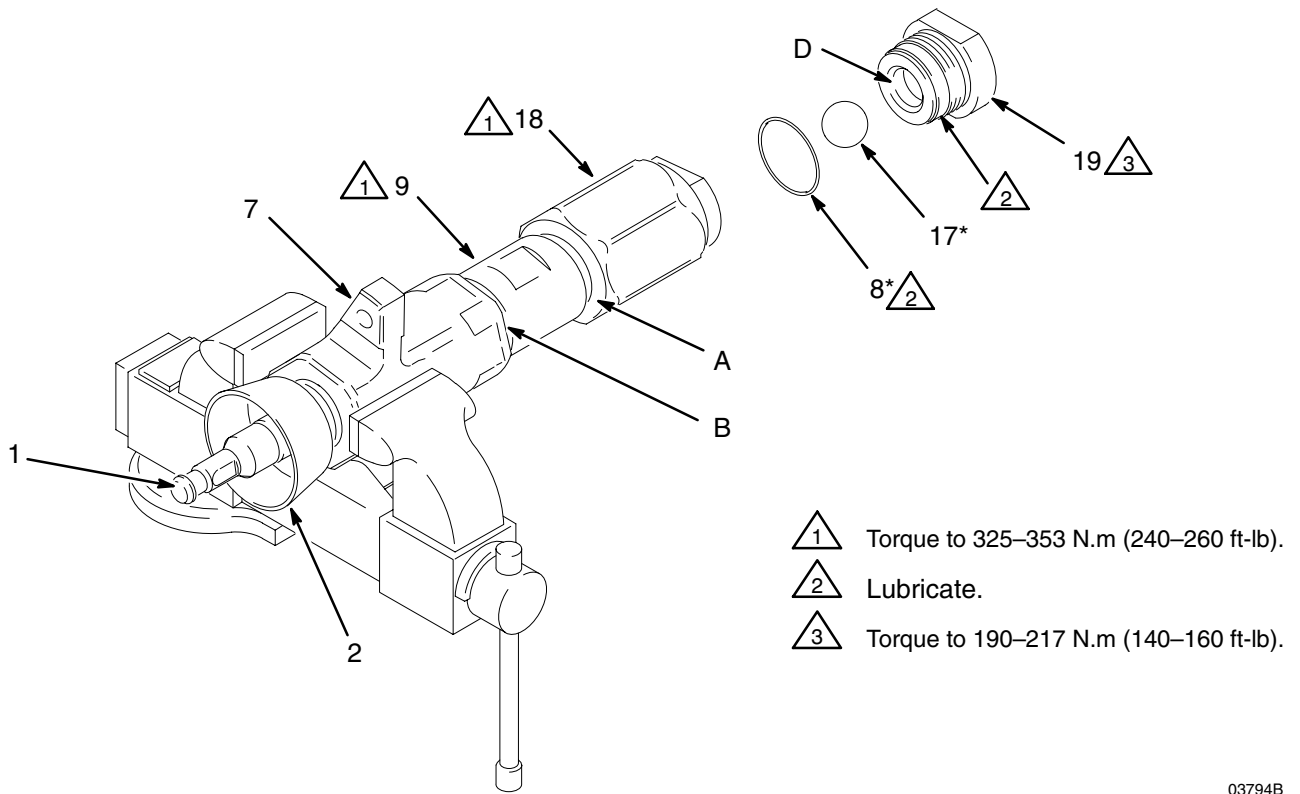

Fig. 7

03794B

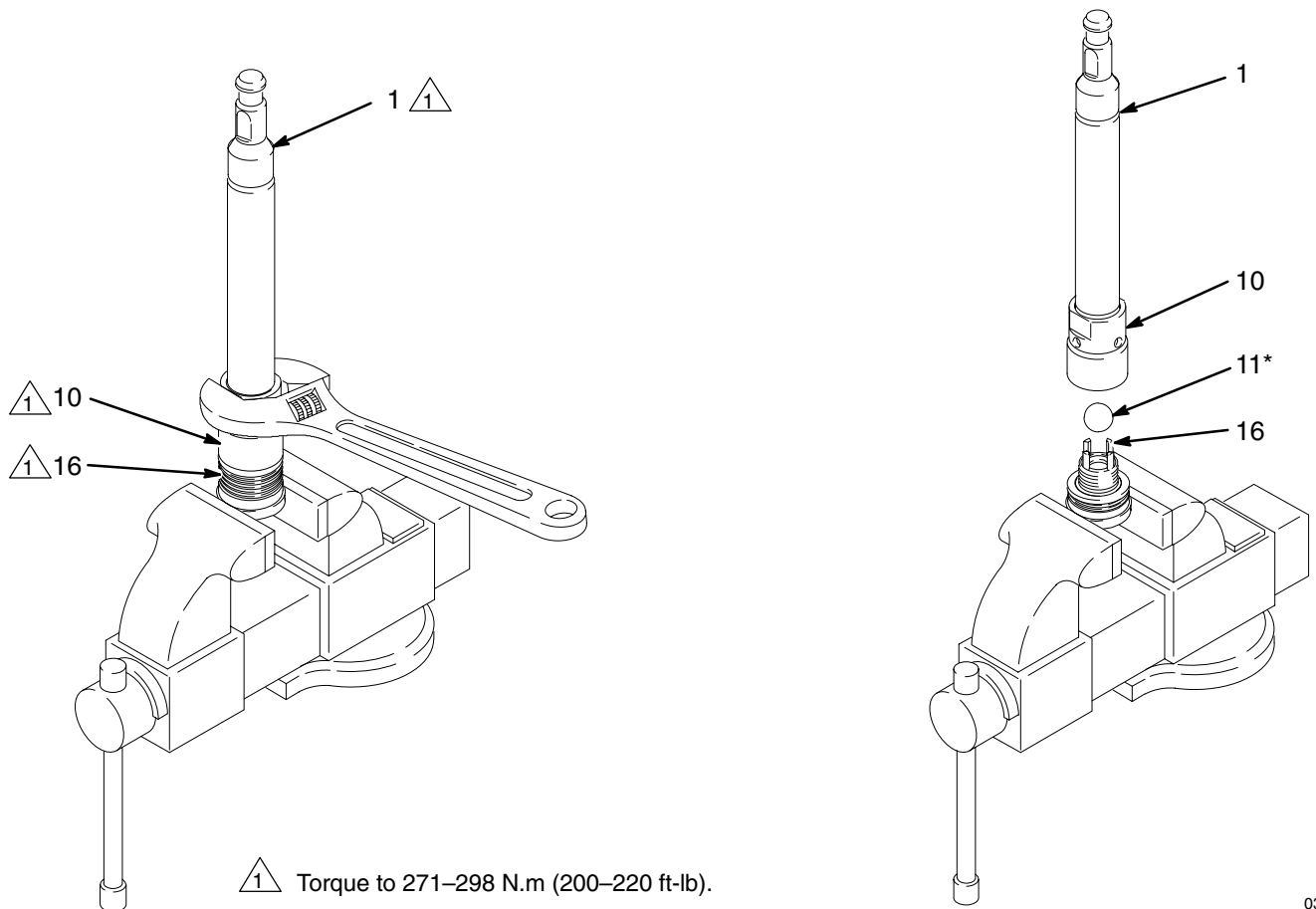

Fig. 8

03793A

Service

Reassembly

1. *If it was necessary to remove the piston ball housing (10) from the displacement rod (1), clean the threads of the rod and the ball housing. Screw the ball housing onto the rod, hand tight. Place the flats of the piston ball housing in a vise and torque the rod to 271–298 N.m (200–220 ft-lb). See Fig. 9.*
2. For standard displacement pump 236470, place the piston packings on the piston seat housing (16) in the following order, **with the lips of the v-packings facing up**: the female gland (15*), one PTFE v-packing (14*), four leather v-packings (12*), and the male gland (13*). See the Piston Packing Stack Detail in Fig. 9.

NOTE: If your pump uses an optional packing configuration, or you want to convert the pump to a different packing material, see page 27.

3. Place the flats of the piston seat housing (16) in a vise. Place the ball (11*) on the housing. Screw the piston ball housing (10) onto the piston seat housing hand tight, then torque to 271–298 N.m (200–220 ft-lb). See Fig. 8.
4. For standard displacement pump 236470, lubricate the throat packings and place them in the outlet housing (7) in the following order, **with the lips of the v-packings facing down**: the male gland (6*), four leather v-packings (3*), one PTFE v-packing (5*), and the female gland (4*). See the Throat Packing Stack Detail in Fig. 9.

NOTE: If your pump uses an optional packing configuration, or you want to convert the pump to a different packing material, see page 27.

5. Install the packing nut (2) loosely into the outlet housing (7).

6. Lubricate the piston packings. Slide the displacement rod (1) and piston assembly down into the cylinder (9). The cylinder is symmetrical, so either end may face up. Use a rubber mallet to drive the rod into the cylinder, until the piston seat housing (16) is near the bottom of the cylinder.
7. Install the seal (8*) on the top of the cylinder (9). Lubricate the seal and the top threads of the cylinder.
8. Place the outlet housing (7) in a vise, as shown in Fig. 7. Slide the displacement rod (1) up into the outlet housing, then screw the cylinder (9) into the outlet housing handtight. The threads will engage easily until the seal (8*) contacts the sealing surface of the outlet housing. The top of the rod will protrude from the packing nut (2).
9. Install the seal (8*) on the bottom of the cylinder (9). Lubricate the seal and the threads of the cylinder. **With the beveled ball stop surfaces (S) facing down (see Fig. 9),** screw the intake housing (18) onto the cylinder handtight. The threads will engage easily until the seal contacts the sealing surface of the intake housing.
10. Install the seal (8*) on the intake valve (19). Lubricate the seal and the threads of the intake valve. Place the intake ball (17*) in the intake housing (18), then screw the intake valve into the intake housing handtight. The threads will engage easily until the seal contacts the sealing surface of the intake housing.
11. Using a pipe wrench, torque the intake housing (18) to 325–353 N.m (240–260 ft-lb). This will torque both cylinder joints (A and B). See Fig. 7.
12. Using a pipe wrench, torque the intake valve (19) to 190–217 N.m (140–150 ft-lb). See Fig. 7.
13. Torque the packing nut (2) to 136–149 N.m (100–110 ft-lb).
14. Reconnect the displacement pump to the air motor as explained on page 16.

Service

△1 Torque to 136–149 N.m (100–110 ft-lb).

△2 Torque to 325–353 N.m (240–260 ft-lb).

△3 Torque to 271–298 N.m (200–220 ft-lb).

△4 Lubricate.

△5 Lips face up.

△6 Lips face down.

△7 See Throat Packing Detail at left.

△8 See Piston Packing Detail at left.

△9 Torque to 190–217 N.m (140–160 ft-lb).

Throat Packing Stack Detail
(Displacement Pump 236470 Shown;
see page 27 for options.)

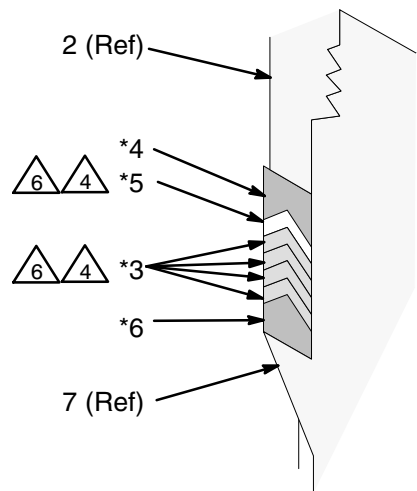

Piston Packing Stack Detail
(Displacement Pump 236470 Shown;
see page 27 for options.)

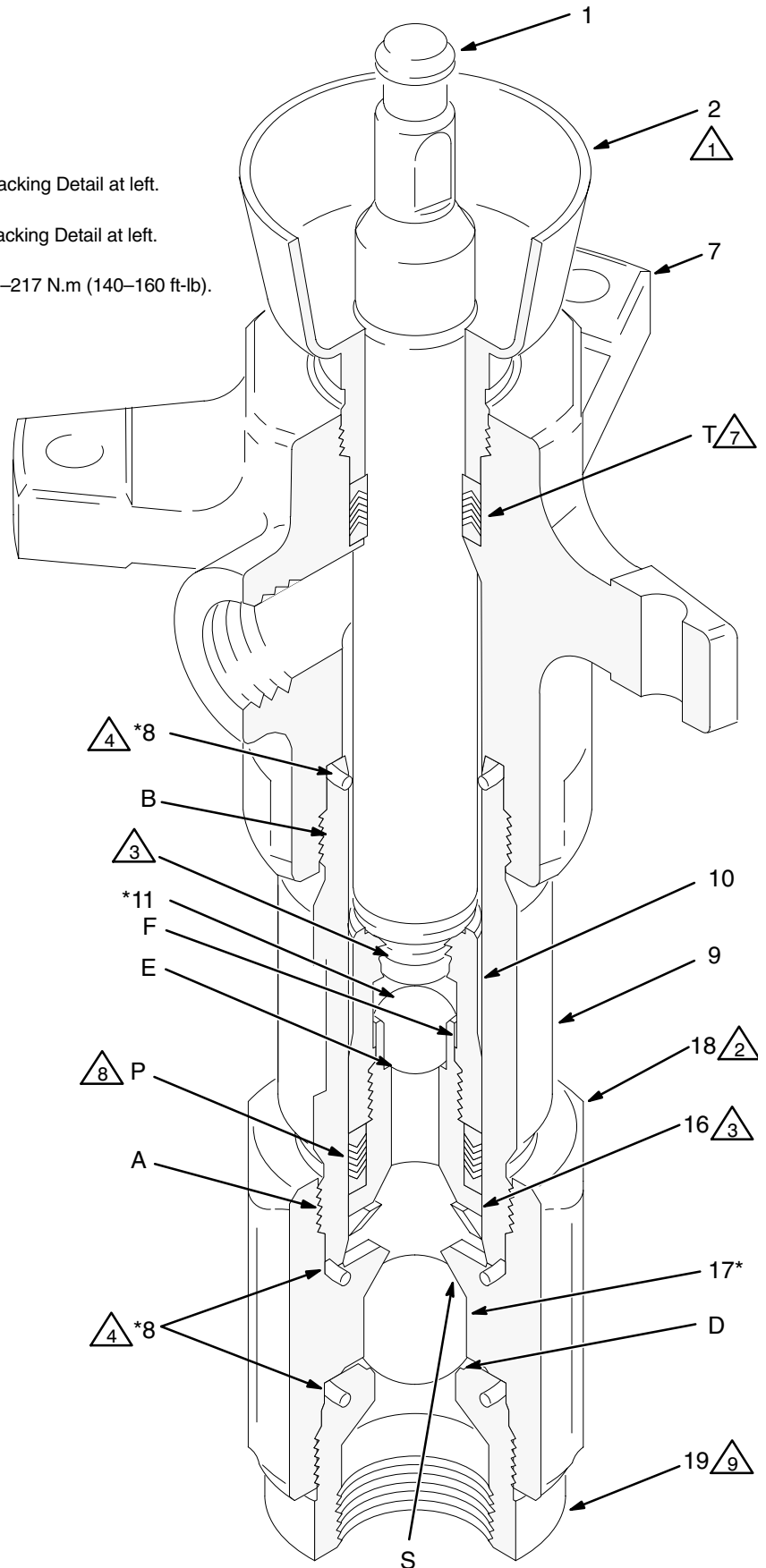
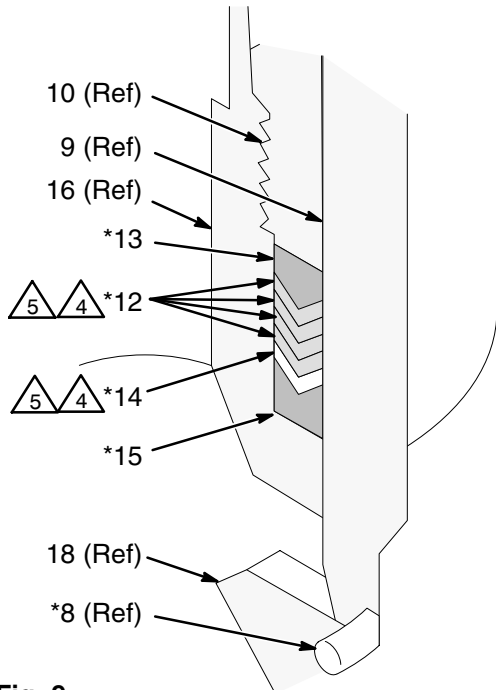

Fig. 9

03634B

Parts

Part No. 237286 Pump, Series B
56:1 Ratio, with Reduced Icing
Quiet King Air Motor

Part No. 245172 Pump, Series A
56:1 Ratio, with King Air Motor

Part No. 245173 Pump, Series A
56:1 Ratio, with Quiet King Air Motor

Ref. No.	Part No.	Description	Qty.
101	245112	AIR MOTOR, King, reduced icing <i>For Model 237286</i>	1
		See 309348 for parts	
	245111	AIR MOTOR, King <i>For Model 245172</i>	1
		See 309347 for parts	
	220106	AIR MOTOR, Quiet King <i>For Model 245173</i>	1
		See 309348 for parts	
102▲	176529	LABEL, warning	1
105†	190000	ROD, tie; 224 mm (8.82") shoulder to shoulder; carbon steel	3
106†	186925	NUT, coupling	1
107†	184129	COLLAR, coupling	2
108†	106166	NUT, hex; M16 x 2.0	3
109	236470	PUMP, displacement See page 26 for parts	1
110†	112887	WRENCH, spanner	1

▲ Replacement Danger and Warning labels, tags and cards are available at no cost.

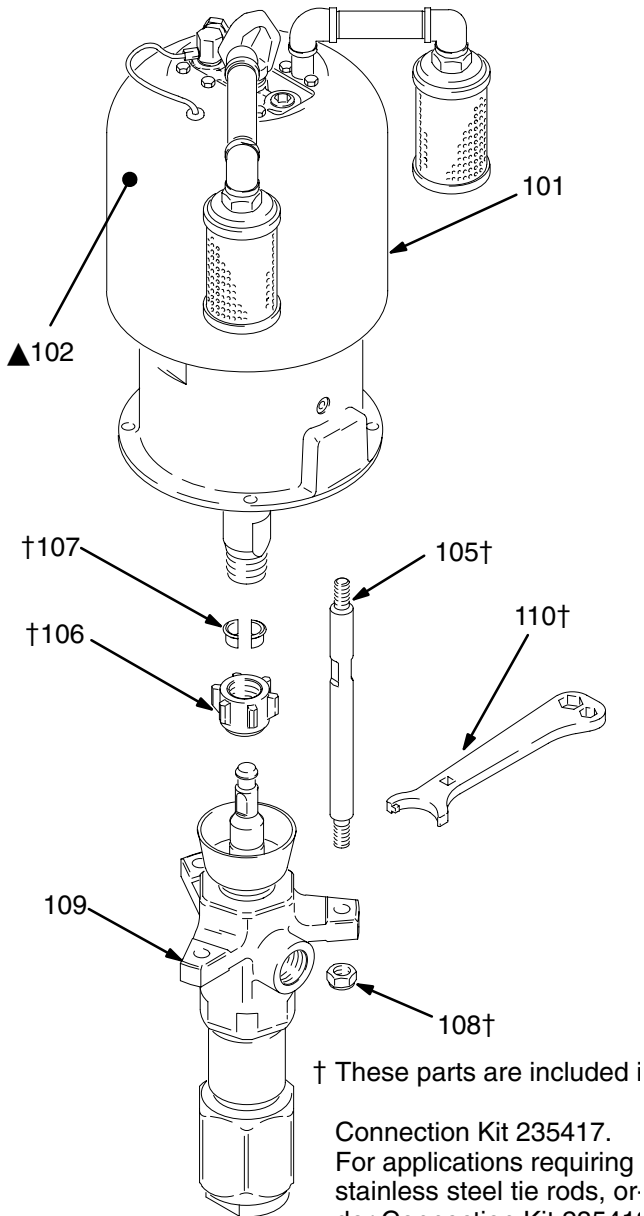

Parts

Part No. 237287 Pump, Series A 28:1 Ratio, with Bulldog Air Motor

Ref. No.	Part No.	Description	Qty.
101	208356	AIR MOTOR, Bulldog See 307049 for parts	1
102▲	176529	LABEL, warning	1
105†	190000	ROD, tie; 224 mm (8.82") shoulder to shoulder; carbon steel	3
106†	186925	NUT, coupling	1
107†	184129	COLLAR, coupling	2
108†	106166	NUT, hex; M16 x 2.0	3
109	236470	PUMP, displacement See page 26 for parts	1
110†	112887	WRENCH, spanner	1

▲ Replacement Danger and Warning labels, tags and cards are available at no cost.

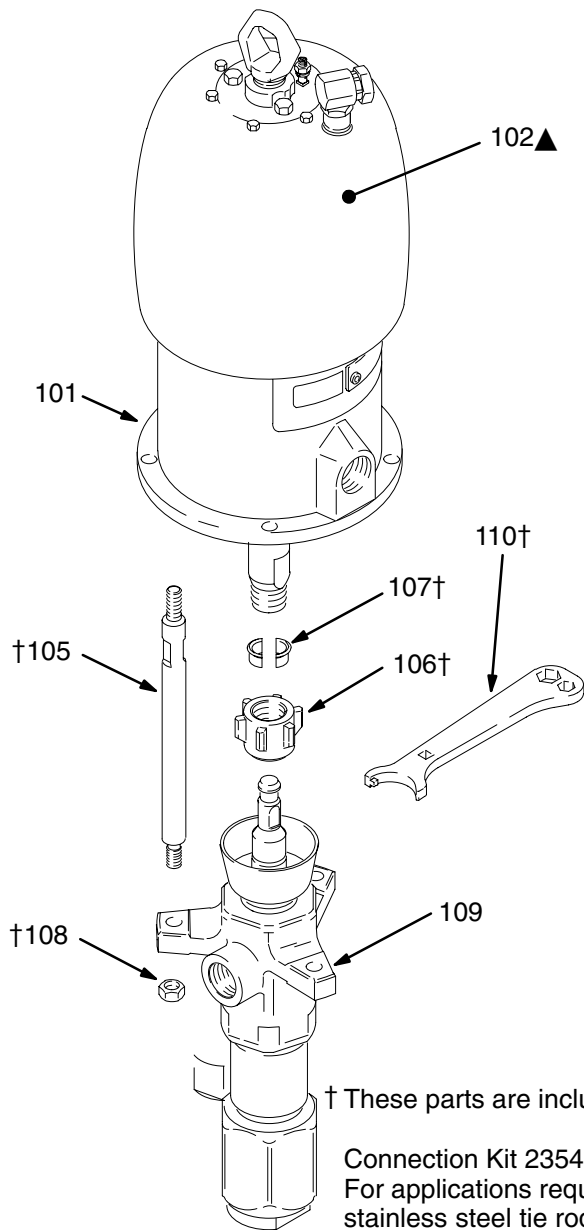

† These parts are included in
Connection Kit 235417.
For applications requiring
stainless steel tie rods, or-
der Connection Kit 235419

Parts

Part No. 237280 Pump, Series A 17:1 Ratio, with Senator Air Motor

Ref. No.	Part No.	Description	Qty.
101	217540	AIR MOTOR, Senator See 307592 for parts	1
102▲	176529	LABEL, warning	1
105†	190000	ROD, tie; 224 mm (8.82") shoulder to shoulder; carbon steel	3
106†	186925	NUT, coupling	1
107†	184129	COLLAR, coupling	2
108†	106166	NUT, hex; M16 x 2.0	3
109	236470	PUMP, displacement See page 26 for parts	1
110†	112887	WRENCH, spanner	1

▲ Replacement Danger and Warning labels, tags and cards are available at no cost.

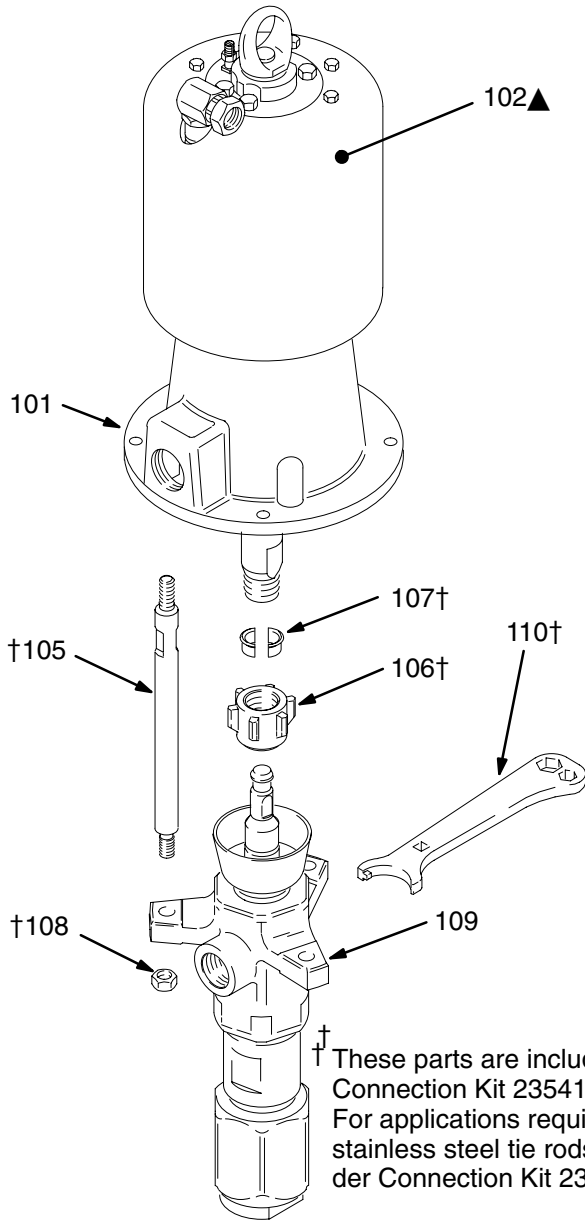

04141B

Parts

**Part No. 237290 Pump, Series A, with
Viscount II Hydraulic Motor**

**Part No. 248817 Pump, Series A, with
Viscount II Hydraulic Motor**

Ref. No.	Part No.	Description	Qty.
101	235345	HYDRAULIC MOTOR, Viscount See 307158 for parts	1
103	190287	ADAPTER, connecting rod	1
105	184596	ROD, tie; 315 mm (12.40") shoulder to shoulder	3
106	186925	NUT, coupling	1
107	184129	COLLAR, coupling	2
108	106166	NUT, hex; M16 x 2.0	3
109	236470	PUMP, displacement <i>For Model 237290</i>	1
	236466	PUMP, displacement <i>For Model 248817</i>	1
110	112887	WRENCH, packing nut See page 26 for parts	1

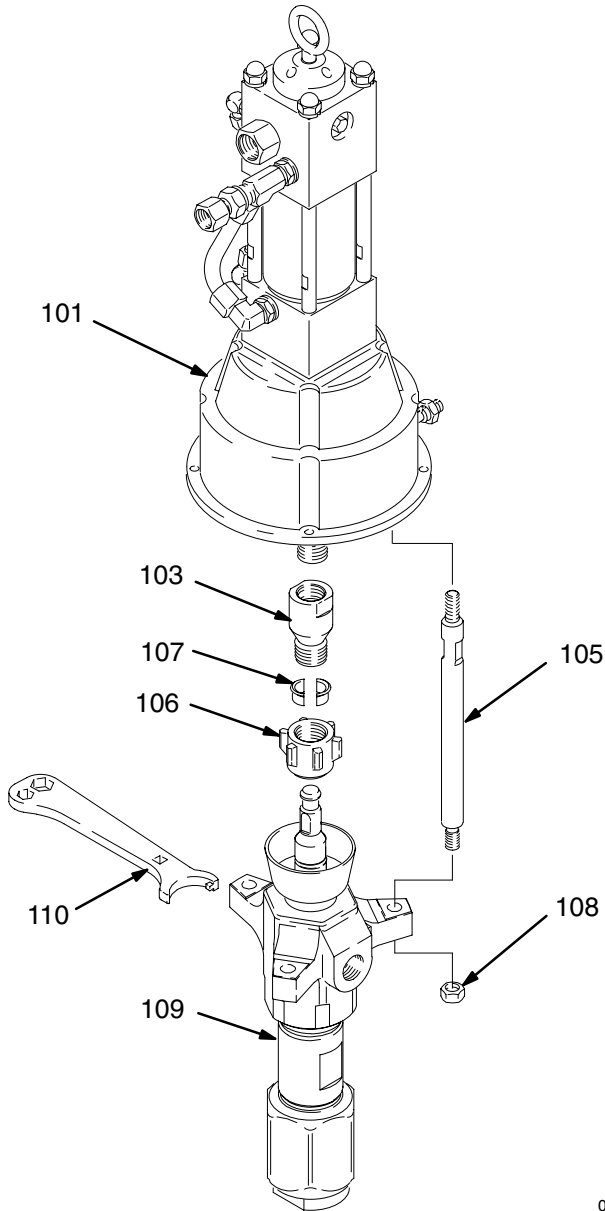

05192B

Parts

NOTE: The parts listed on this page are common to all displacement pumps covered in this manual. Refer to page 27 for the different packing configurations available.

* These parts are included in Repair Kit 237172, which may be purchased separately for standard Displacement Pump 236470. See page 27. They are also included in Conversion Kits 237173, 237174, and 237710.

▲ Replacement Danger and Warning labels, tags and cards are available at no cost.

Ref No.	Part No.	Description	Qty
1	189316	ROD, displacement; stainless steel	1
2	236582	PACKING NUT; stainless steel	1
7	237182	HOUSING, outlet; stainless steel	1
8*	109499	SEAL; PTFE	3
9	189383	CYLINDER; stainless steel	1
10	189408	HOUSING, ball, piston; carbon steel	1
11*	101859	BALL, piston; stainless steel; 0.75" (22.2 mm) dia.	1
16	236587	HOUSING, seat, piston valve; stainless steel w/tungsten carbide seat	1
17*	108001	BALL, intake; stainless steel; 1.5" (38.1 mm) dia.	1
18	189396	VALVE HOUSING, intake; stainless steel	1
19	236588	VALVE, intake; stainless steel w/tungsten carbide seat	1
22	101748	PLUG, pipe, socket hd; 3/8 npt; stainless steel	1
24▲	172477	TAG, warning (not shown)	1
25▲	172479	TAG, warning (not shown)	1

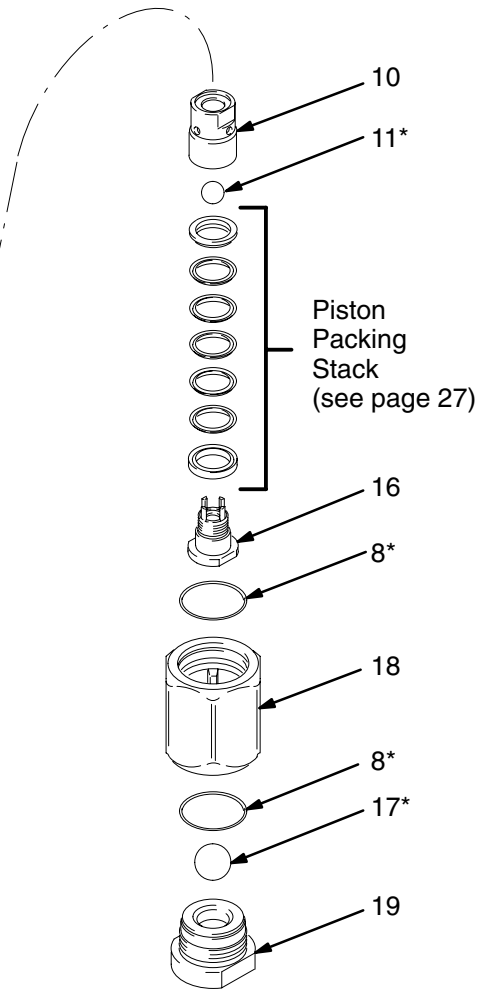
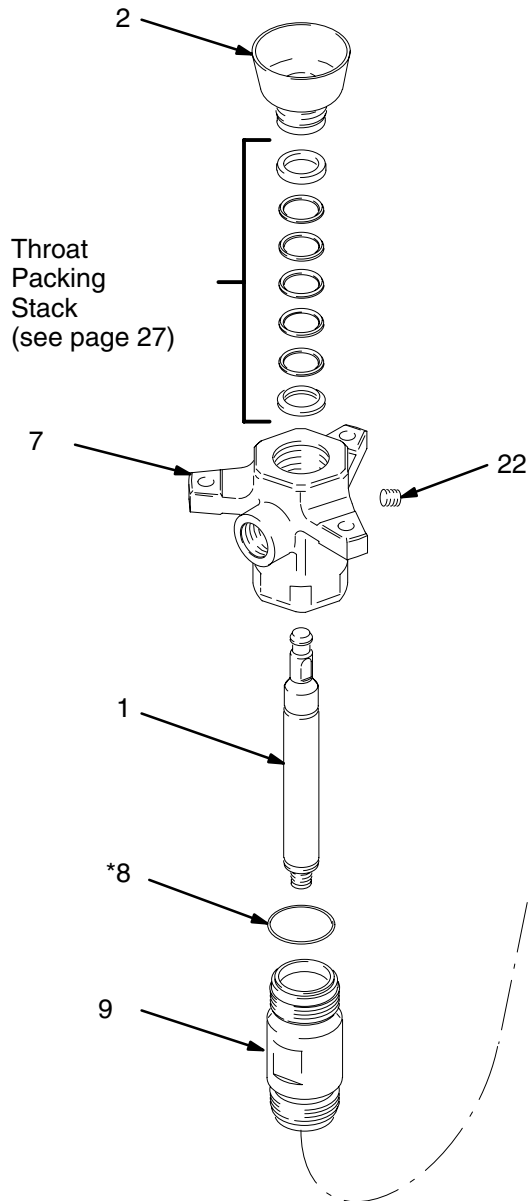

03630B

Packing Kits

Leather Packing Kit 237172, for Standard Displacement Pump 236470, Series A

Ref No.	Part No.	Description	Qty
3*	184304	V-PACKING, throat; leather	4
4*	184174	GLAND, throat, female; stainless steel	1
5*	109304	V-PACKING, throat; PTFE	1
6*	184224	GLAND, throat, male; stainless steel	1
12*	184305	V-PACKING, piston; leather	4
13*	184225	GLAND, piston, male; stainless steel	1
14*	109305	V-PACKING, piston; PTFE	1
15*	184175	GLAND, piston, female; stainless steel	1

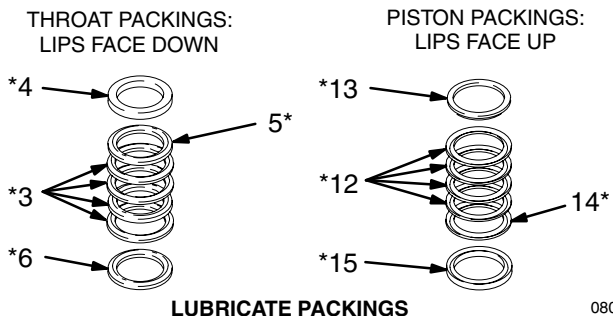

0805
0806

* Kit also includes items 8, 11, and 17 (see page 26).

PTFE Packing Kit 237173, for Optional Displacement Pump 236897, Series A

Ref No.	Part No.	Description	Qty
4*	184174	GLAND, throat, female; stainless steel	1
5*	109304	V-PACKING, throat; PTFE	5
6*	184224	GLAND, throat, male; stainless steel	1
13*	184225	GLAND, piston, male; stainless steel	1
14*	109305	V-PACKING, piston; PTFE	5
15*	184175	GLAND, piston, female; stainless steel	1

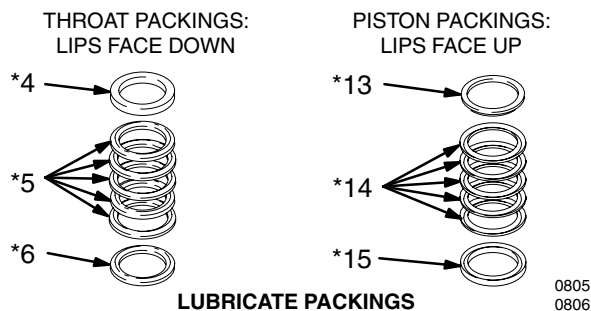

0805
0806

* Kit also includes items 8, 11, and 17 (see page 26).

UHMWPE and Leather Packing Kit 237174 (Optional)

Ref No.	Part No.	Description	Qty
3*	184304	V-PACKING, throat; leather	2
4*	184174	GLAND, throat, female; stainless steel	1
5*	109254	V-PACKING, throat; UHMWPE	3
6*	184224	GLAND, throat, male; stainless steel	1
12*	184305	V-PACKING, piston; leather	2
13*	184225	GLAND, piston, male; stainless steel	1
14*	109255	V-PACKING, piston; UHMWPE	3
15*	184175	GLAND, piston, female; stainless steel	1

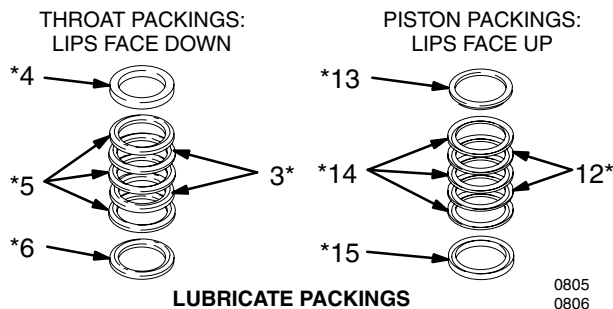

0805
0806

Kit also includes items 8, 11, and 17 (see page 26).

UHMWPE and PTFE Packing Kit 237710 (Optional)

Ref No.	Part No.	Description	Qty
3*	109304	V-PACKING, throat; PTFE	2
4*	184174	GLAND, throat, female; stainless steel	1
5*	109254	V-PACKING, throat; UHMWPE	3
6*	184224	GLAND, throat, male; stainless steel	1
12*	109305	V-PACKING, piston; PTFE	2
13*	184225	GLAND, piston, male; stainless steel	1
14*	109255	V-PACKING, piston; UHMWPE	3
15*	184175	GLAND, piston, female; stainless steel	1

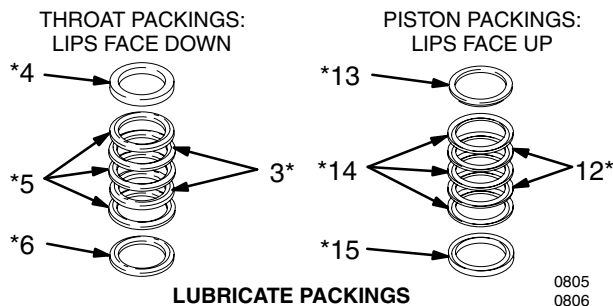

0805
0806

Kit also includes items 8, 11, and 17 (see page 26).

Technical Data

(Model 237286 Reduced Icing Quiet King Pump,
Model 245173 Quiet King Pump, and
Model 245172 King Pump)

⚠ WARNING

Be sure that all fluids and solvents used are chemically compatible with the Wetted Parts listed below. Always read the manufacturer's literature before using fluid or solvent in this pump.

Ratio	56:1
Maximum fluid working pressure	38.6 MPa, 386 bar (5600 psi)
Maximum air input pressure	0.7 MPa, 7 bar (100 psi)
Pump cycles per 3.8 liters (1 gal.)	18
Fluid flow at 60 cycles/min	12.9 liters/min (3.4 gpm)
Air motor piston effective area	506 cm ² (78.5 in. ²)
Stroke length	120 mm (4.75 in.)
Displacement pump effective area	9 cm ² (1.40 in. ²)
Maximum pump operating temperature	82°C (180°F)
* Noise level at 90 psi, 25 cycles/min	87 dBa
* Sound power level at 90 psi, 25 cycles/min	101 dBa
Air inlet size	3/4 npsm(f)
Fluid inlet size	2" npt(f)
Fluid outlet size	1" npt(f)
Weight	approx. 109 kg (240 lb)
Wetted parts	316, 440 and 17-4 PH Grades of Stainless Steel; Tungsten Carbide; PTFE; Glass-Filled PTFE; Leather

* Tested in accordance with ISO 3744.

KEY: Fluid Outlet Pressure – Black Curves
Air Consumption – Gray Curves

A 6.3 bar (90 psi) Air Pressure
B 4.9 bar (70 psi) Air Pressure
C 2.8 bar (40 psi) Air Pressure

NOTE: Recommended pump speed for continuous operation (to shaded area): 60 cpm

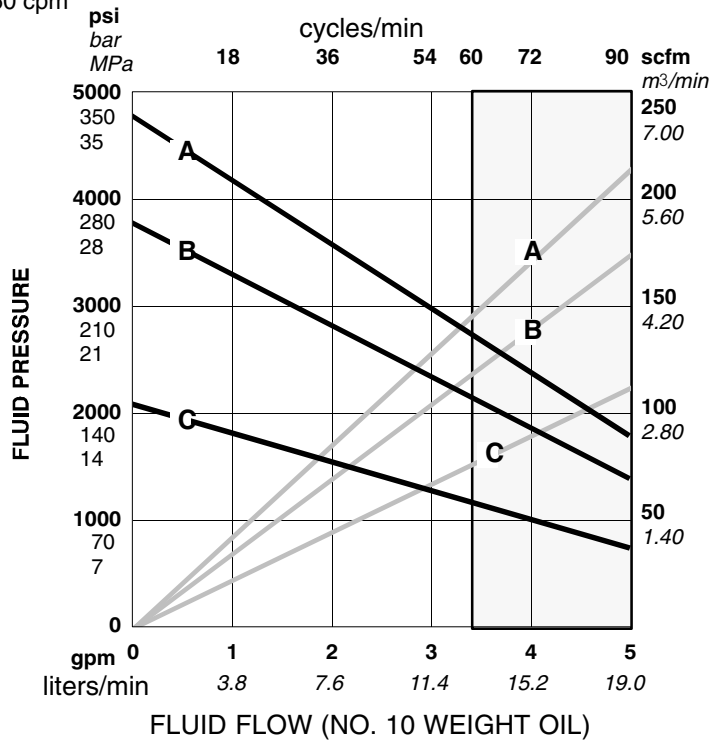

To find Fluid Outlet Pressure (bar/psi) at a specific fluid flow (lpm/gpm) and operating air pressure (bar/psi):

1. Locate desired flow along bottom of chart.
2. Follow vertical line up to intersection with selected fluid outlet pressure curve (black). Follow left to scale to read fluid outlet pressure.

To find Pump Air Consumption (m³/min or scfm) at a specific fluid flow (lpm/gpm) and air pressure (bar/psi):

1. Locate desired flow along bottom of chart.
2. Read vertical line up to intersection with selected air consumption curve (gray). Follow right to scale to read air consumption.

Technical Data

(Model 237287 Bulldog Pump)

⚠ WARNING

Be sure that all fluids and solvents used are chemically compatible with the Wetted Parts listed below. Always read the manufacturer's literature before using fluid or solvent in this pump.

Ratio	28:1
Maximum fluid working pressure	19.3 MPa, 193 bar (2800 psi)
Maximum air input pressure	0.7 MPa, 7 bar (100 psi)
Pump cycles per 3.8 liters (1 gal.)	18
Fluid flow at 60 cycles/min	12.9 liters/min (3.4 gpm)
Air motor piston effective area	248 cm ² (38 in. ²)
Stroke length	120 mm (4.75 in.)
Displacement pump effective area	12 cm ² (1.86 in. ²)
Maximum pump operating temperature	82°C (180°F)
* Noise level at 100 psi, 25 cycles/min	94 dBA
* Sound power level at 100 psi, 25 cycles/min	109 dBA
Air inlet size	3/4 npsm(f)
Fluid inlet size	2" npt(f)
Fluid outlet size	1" npt(f)
Weight	approx. 109 kg (240 lb)
Wetted parts	316, 440 and 17-4 PH Grades of Stainless Steel; Tungsten Carbide; PTFE; Glass-Filled PTFE; Leather

* Tested in accordance with ISO 3744.

KEY: Fluid Outlet Pressure – Black Curves
Air Consumption – Gray Curves

A 0.7MPa, 7 bar (100 psi) Air Pressure
B 0.5 MPa, 4.9 bar (70 psi) Air Pressure
C 0.3 MPa, 2.8 bar (40 psi) Air Pressure

NOTE: Recommended pump speed for continuous operation (to shaded area): 60 cpm

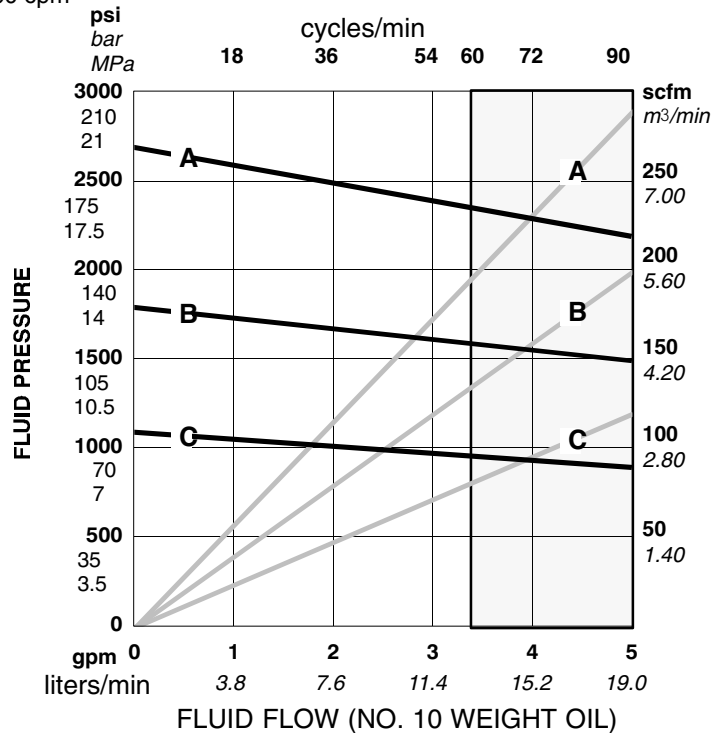

To find Fluid Outlet Pressure (bar/psi) at a specific fluid flow (lpm/gpm) and operating air pressure (bar/psi):

1. Locate desired flow along bottom of chart.
2. Follow vertical line up to intersection with selected fluid outlet pressure curve (black). Follow left to scale to read fluid outlet pressure.

To find Pump Air Consumption (m³/min or scfm) at a specific fluid flow (lpm/gpm) and air pressure (bar/psi):

1. Locate desired flow along bottom of chart.
2. Read vertical line up to intersection with selected air consumption curve (gray). Follow right to scale to read air consumption.

Technical Data

(Model 237280 Senator Pump)

⚠ WARNING

Be sure that all fluids and solvents used are chemically compatible with the Wetted Parts listed below. Always read the manufacturer's literature before using fluid or solvent in this pump.

Ratio	17:1
Maximum fluid working pressure	11.7 MPa, 117 bar (1700 psi)
Maximum air input pressure	0.7 MPa, 7 bar (100 psi)
Pump cycles per 3.8 liters (1 gal.)	18
Fluid flow at 60 cycles/min	12.9 liters/min (3.4 gpm)
Air motor piston effective area	154 cm ² (24 in. ²)
Stroke length	120 mm (4.75 in.)
Displacement pump effective area	9 cm ² (1.40 in. ²)
Maximum pump operating temperature	82°C (180°F)
* Noise level at 100 psi, 25 cycles/min	93 dBa
* Sound power level at 100 psi, 25 cycles/min	108 dBa
Air inlet size	3/4 npsm(f)
Fluid inlet size	2" npt(f)
Fluid outlet size	1" npt(f)
Weight	approx. 109 kg (240 lb)
Wetted parts	316, 440 and 17-4 PH Grades of Stainless Steel; Tungsten Carbide; PTFE; Glass-Filled PTFE; Leather

* Tested in accordance with ISO 3744.

KEY: Fluid Outlet Pressure – Black Curves
Air Consumption – Gray Curves

A 0.7 MPa, 7 bar (100 psi) Air Pressure
B 0.5 MPa, 4.9 bar (70 psi) Air Pressure
C 0.3 MPa, 2.8 bar (40 psi) Air Pressure

NOTE: Recommended pump speed for continuous operation (to shaded area): 60 cpm

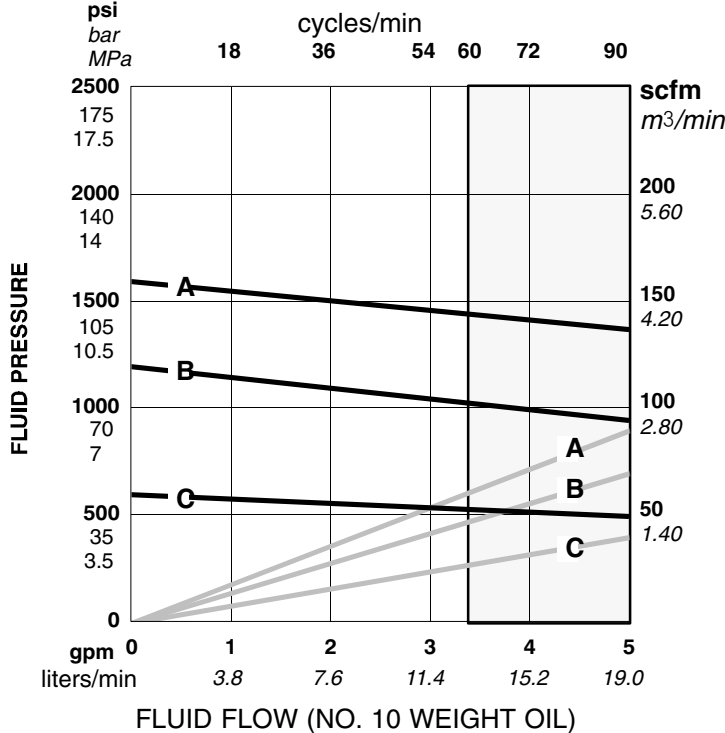

To find Fluid Outlet Pressure (bar/psi) at a specific fluid flow (lpm/gpm) and operating air pressure (bar/psi):

1. Locate desired flow along bottom of chart.
2. Follow vertical line up to intersection with selected fluid outlet pressure curve (black). Follow left to scale to read fluid outlet pressure.

To find Pump Air Consumption (m³/min or scfm) at a specific fluid flow (lpm/gpm) and air pressure (bar/psi):

1. Locate desired flow along bottom of chart.
2. Read vertical line up to intersection with selected air consumption curve (gray). Follow right to scale to read air consumption.

Technical Data

(Model 237290 Viscount II Pump and
Model 248817 Viscount Pump)

WARNING

Be sure that all fluids and solvents used are chemically compatible with the Wetted Parts listed below. Always read the manufacturer's literature before using fluid or solvent in this pump.

Category	Data
Ratio	3.5:1
Maximum fluid working pressure	34 MPa, 345 bar (5000 psi)
Maximum hydraulic oil input pressure	9.9 MPa, 99 bar (1428 psi)
Pump cycles per 3.8 liters (1 gal.)	18
Fluid flow at 60 cycles/min	12.9 liters/min (3.4 gpm)
Hydraulic motor piston effective area	31.6 cm ² (4.9 in. ²)
Stroke length	120 mm (4.75 in.)
Displacement pump effective area	9 cm ² (1.40 in. ²)
Maximum pump operating temperature	82°C (180°F)
* Noise level at 1450 psi hydraulic pressure, 25 cycles/min	88 dB(A)
* Sound power level at 1450 psi hydraulic pressure, 25 cycles/min	103 dB(A)
Hydraulic oil inlet size	3/4 npt(f)
Fluid inlet size	2" npt(f)
Fluid outlet size	1" npt(f)
Weight	approx. 68 kg (150 lb)
Wetted parts	Carbon Steel; Chrome Steel; Alloy Steel; Chrome, Zinc, and Nickel Plating; 440 and 17-4 PH Grades of Stainless Steel; Ductile Iron; Tungsten Carbide; PTFE; Glass-Filled PTFE; Leather (<i>displacement pump 236466 only</i>)

* Tested in accordance with ISO 3744.

Technical Data

(Model 237290 Viscount II Pump and Model 248817 Viscount Pump)

Performance Charts

To find Fluid Outlet Pressure (psi/MPa/bar) at a specific fluid flow (lpm/gpm) and operating hydraulic pressure (psi/MPa/bar):

1. Locate desired flow along bottom of chart.
2. Follow vertical line up to intersection with selected fluid outlet pressure curve (black). Follow left to scale to read fluid outlet pressure.

To find Pump Hydraulic Oil Consumption (gpm or lpm) at a specific fluid flow (lpm/gpm):

1. Locate desired flow along bottom of chart.
2. Read vertical line up to intersection with selected hydraulic consumption curve (dashes). Follow left to scale to read oil consumption.

- A** 9.9 MPa, 99 bar (1428 psi) hydraulic oil pressure
- B** 7 MPa, 70 bar (1000 psi) hydraulic pressure
- C** 4 MPa, 40 bar (571 psi) hydraulic pressure

Test Fluid: No. 10 Weight Oil

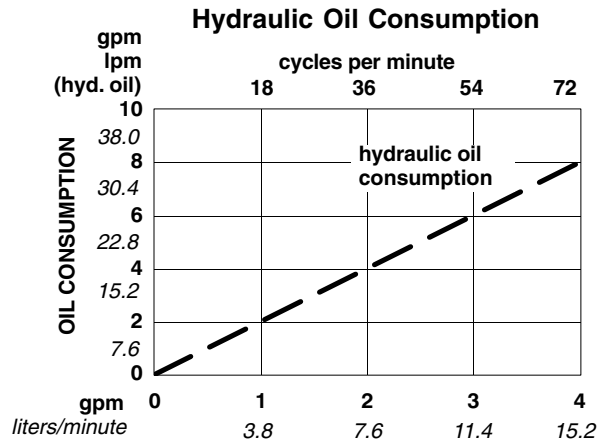
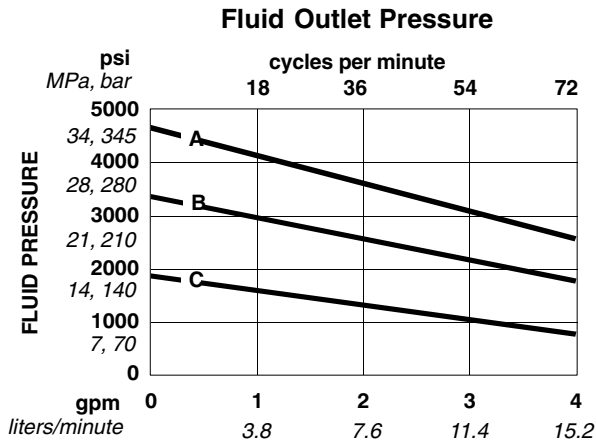

Dimensions

Model 237287 Shown

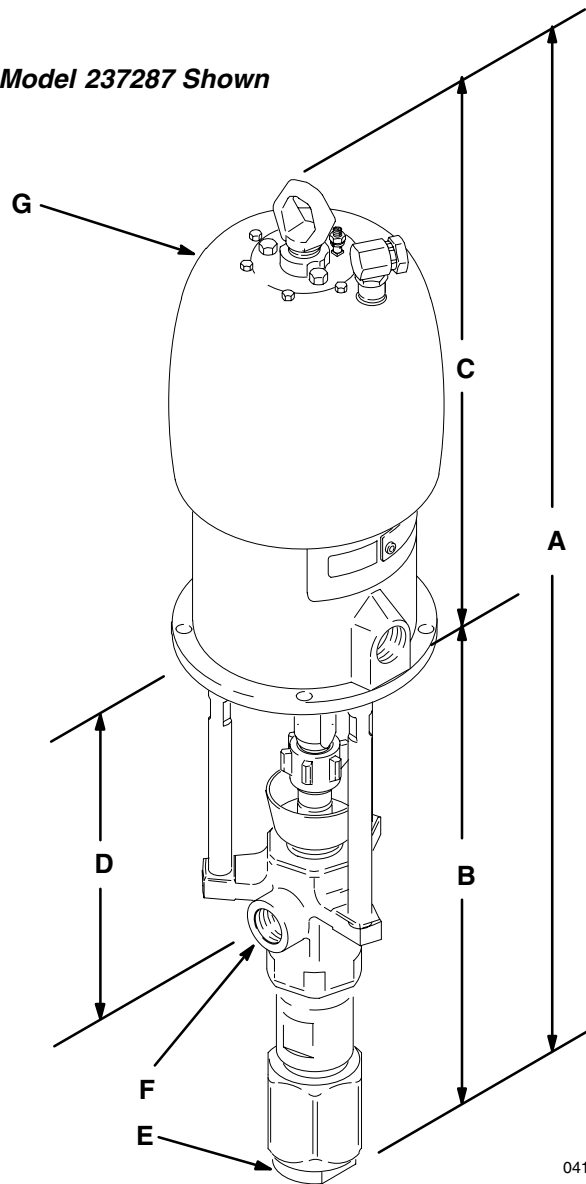

04143B

Mounting Hole Layout

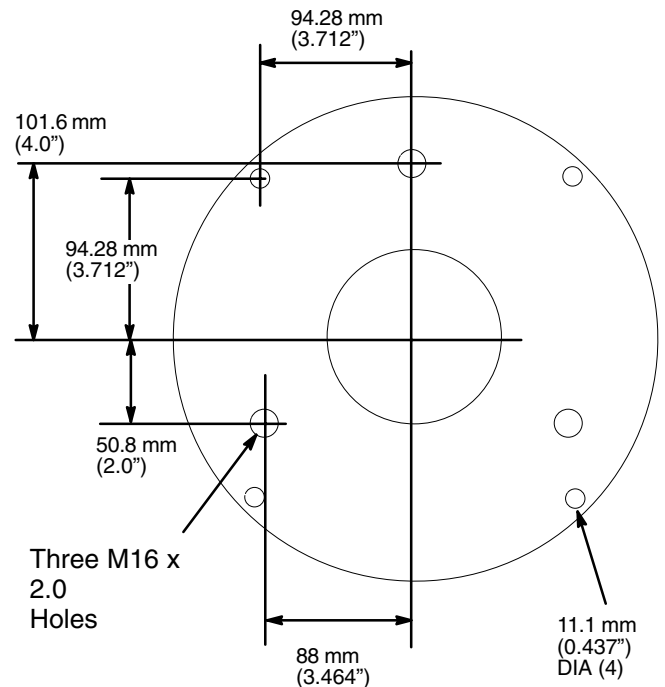

0653

Pump Model	A	B	C	D	E	F	G
237280	1138 mm (44.80 in.)	590 mm (23.23 in.)	548 mm (21.57 in.)	257 mm (10.12 in.)	2 in. npt(f)	1 in. npt(f)	3/4 npsm(f)
237286	1180 mm (46.44 in.)	590 mm (23.23 in.)	590 mm (23.21 in.)	257 mm (10.12 in.)	2 in. npt(f)	1 in. npt(f)	3/4 npsm(f)
237287	1134 mm (44.65 in.)	590 mm (23.23 in.)	544 mm (21.42 in.)	257 mm (10.12 in.)	2 in. npt(f)	1 in. npt(f)	3/4 npsm(f)
245172	1130 mm (44.49 in.)	590 mm (23.23 in.)	540 mm (21.26 in.)	257 mm (10.12 in.)	2 in. npt(f)	1 in. npt(f)	3/4 npsm(f)
245173	1136 mm (44.72 in.)	590 mm (23.23 in.)	546 mm (21.5 in.)	257 mm (10.12 in.)	2 in. npt(f)	1 in. npt(f)	3/4 npsm(f)
237290	1344 mm (52.91 in.)	681 mm (26.81 in.)	663 mm (26.10 in.)	not applicable	2 in. npt(f)	1 in. npt(f)	3/4 npt(f)
248817	1344 mm (52.91 in.)	681 mm (26.81 in.)	663 mm (26.10 in.)	not applicable	2 in. npt(f)	1 in. npt(f)	3/4 npt(f)

Graco Standard Warranty

Graco warrants all equipment manufactured by Graco and bearing its name to be free from defects in material and workmanship on the date of sale to the original purchaser. With the exception of any special, extended, or limited warranty published by Graco, Graco will, for a period of twelve months from the date of sale, repair or replace any part of the equipment determined by Graco to be defective. This warranty applies only when the equipment is installed, operated and maintained in accordance with Graco's written recommendations.

This warranty does not cover, and Graco shall not be liable for general wear and tear, or any malfunction, damage or wear caused by faulty installation, misapplication, abrasion, corrosion, inadequate or improper maintenance, negligence, accident, tampering, or substitution of non-Graco component parts. Nor shall Graco be liable for malfunction, damage or wear caused by the incompatibility of Graco equipment with structures, accessories, equipment or materials not supplied by Graco, or the improper design, manufacture, installation, operation or maintenance of structures, accessories, equipment or materials not supplied by Graco.

This warranty is conditioned upon the prepaid return of the equipment claimed to be defective to an authorized Graco distributor for verification of the claimed defect. If the claimed defect is verified, Graco will repair or replace free of charge any defective parts. The equipment will be returned to the original purchaser transportation prepaid. If inspection of the equipment does not disclose any defect in material or workmanship, repairs will be made at a reasonable charge, which charges may include the costs of parts, labor, and transportation.

THIS WARRANTY IS EXCLUSIVE, AND IS IN LIEU OF ANY OTHER WARRANTIES, EXPRESS OR IMPLIED, INCLUDING BUT NOT LIMITED TO WARRANTY OF MERCHANTABILITY OR WARRANTY OF FITNESS FOR A PARTICULAR PURPOSE.

Graco's sole obligation and buyer's sole remedy for any breach of warranty shall be as set forth above. The buyer agrees that no other remedy (including, but not limited to, incidental or consequential damages for lost profits, lost sales, injury to person or property, or any other incidental or consequential loss) shall be available. Any action for breach of warranty must be brought within two (2) years of the date of sale.

Graco makes no warranty, and disclaims all implied warranties of merchantability and fitness for a particular purpose in connection with accessories, equipment, materials or components sold but not manufactured by Graco. These items sold, but not manufactured by Graco (such as electric motors, switches, hose, etc.), are subject to the warranty, if any, of their manufacturer. Graco will provide purchaser with reasonable assistance in making any claim for breach of these warranties.

In no event will Graco be liable for indirect, incidental, special or consequential damages resulting from Graco supplying equipment hereunder, or the furnishing, performance, or use of any products or other goods sold hereto, whether due to a breach of contract, breach of warranty, the negligence of Graco, or otherwise.

FOR GRACO CANADA CUSTOMERS

The parties acknowledge that they have required that the present document, as well as all documents, notices and legal proceedings entered into, given or instituted pursuant hereto or relating directly or indirectly hereto, be drawn up in English. Les parties reconnaissent avoir convenu que la rédaction du présente document sera en Anglais, ainsi que tous documents, avis et procédures judiciaires exécutés, donnés ou intentés à la suite de ou en rapport, directement ou indirectement, avec les procédures concernées.

Graco Information

TO PLACE AN ORDER, contact your Graco distributor, or call one of the following numbers to identify the distributor closest to you:

1-800-328-0211 Toll Free

612-623-6921

612-378-3505 Fax

Sales Offices: Minneapolis

International Offices: Belgium, Korea, Hong Kong, Japan

www.graco.com

GRACO INC. P.O. BOX 1441 MINNEAPOLIS, MN 55440-1441

PRINTED IN U.S.A. 308354 06/1995, Revised 05/2004