

Moving Fluids

Table of Contents

Introduction	1
<i>Overview</i>	<i>1</i>
<i>How to Use this Module</i>	<i>1</i>
Understanding Your Customer's Situation	3
<i>Learning Objectives</i>	<i>3</i>
<i>Characteristics of the Fluid to be Moved.....</i>	<i>3</i>
<i>Characteristics of the Application</i>	<i>4</i>
<i>Customer Priorities</i>	<i>4</i>
Fluid Containers	5
<i>Learning Objectives</i>	<i>5</i>
<i>Drums</i>	<i>5</i>
<i>Pails</i>	<i>6</i>
<i>Portable Bulk Tanks</i>	<i>6</i>
<i>Bulk Containers</i>	<i>7</i>
Getting the Fluid into the System	11
<i>Learning Objectives</i>	<i>11</i>
<i>Pressure Pots</i>	<i>11</i>
<i>Pump Selection.....</i>	<i>18</i>
<i>Pump Feed Issues</i>	<i>18</i>
<i>Pump Feed Methods.....</i>	<i>25</i>
Delivery Issues	40
<i>Learning Objectives</i>	<i>40</i>
<i>Spray Applications</i>	<i>40</i>
<i>Extrusion Applications.....</i>	<i>40</i>
<i>Transfer Applications</i>	<i>41</i>
<i>Dispense Applications.....</i>	<i>41</i>
<i>Paint Circulation Applications</i>	<i>41</i>
Pipe, Tubing, Fittings, and Hose	42
<i>Learning Objectives</i>	<i>42</i>
<i>Pipe.....</i>	<i>42</i>
<i>Tubing</i>	<i>42</i>
<i>Fittings</i>	<i>43</i>
<i>Hose</i>	<i>44</i>

Below is a listing of trademarks used in this document:

Graco trademarks
Glutton™

Graco, Inc.
P.O. Box 1441
Minneapolis, MN 55440-1441

©1995 Graco Inc. Form No. 321-037 12/95 Printed in U.S.A.

Introduction

Welcome to *Moving Fluids*, a learning module in Graco's concept and theory sales training series. Your understanding of the information in this module provides the basis for further study on specific Graco products. Your ability to successfully promote and sell Graco products depends in part on how well you learn the basics and then apply this knowledge to addressing your customers' needs.

While this curriculum best fits the requirements of Graco and distributor sales people, it will also benefit anyone whose job function depends on knowledge of Graco's products.

Overview

To be effective in the marketplace, Graco and distributor sales people must understand the basic concepts related to moving fluids from a fluid container through a fluid handling system. This module, *Moving Fluids*, introduces those concepts and shows how they relate to the day-to-day world of Graco product selection, recommendation, and sales.

This module assumes participants have a basic understanding of terms and concepts related to fluid properties and characteristics, expressions of measurement, fluid types, basic components of fluids, and curing systems.

How to Use this Module

The basic concept and theory curriculum consists of a series of self-study modules. As the term self-study implies, you work through the materials on your own at a comfortable pace. Plan sufficient time (approximately 30 minutes) to complete at least one section of a module in a working session.

This module combines a variety of features to make the learning process convenient and productive:

- Learning objectives
- Text
- Charts, illustrations
- Progress checks
- Additional resources

Learning objectives

Each section of material offers a set of learning objectives. Read the objectives and use them to guide you to the most important concepts. After you finish each section and before you complete the progress check, reread the objectives to confirm that you understand the key concepts.

Text

Definitions, examples, and explanations comprise the learning module text. Read it carefully and return for review if necessary.

Charts, illustrations

An important element of any instruction is visualizing the concepts. This module contains graphics and illustrations to enhance the text material and aid your learning. Where appropriate, the module also contains charts that help you organize or summarize information.

Progress checks

Progress checks are self-tests that provide reinforcement and confirm your understanding of important topics. After completing each section of the module, return to review the objectives, and then work through each of the progress check items. Upon completion, check your answers against those provided. If you answered any items incorrectly, return to the text and reread the pertinent information.

Additional resources

This module may refer you to other documents or sources that expand on the concepts covered in the module. The reference will include the name of the source and how you can obtain it.

Understanding Your Customer's Situation

Learning Objectives

Before you can help your customer select equipment and accessories for a fluid handling system that will meet their specific needs, you need to understand the customer's current situation and future expectations. This section presents an overview of the factors you need to consider before you begin selecting equipment. We can organize these factors into three main categories: characteristics of the fluid to be moved, characteristics of the application, and customer priorities. After completing this section, you will be able to:

- Identify the characteristics of the fluid being moved that must be considered before recommending equipment and accessories.
- List the characteristics of a customer's application that must be considered before recommending equipment and accessories.
- Recognize potential priorities to discuss with a customer before recommending equipment and accessories.

Characteristics of the Fluid to be Moved

The more you know about the fluid your customer plans to move, the better you will be able to recommend the appropriate equipment and accessories. Most of this information is available from the material manufacturer, either from a material safety data sheet (MSDS), a material technical data sheet, or by calling the manufacturer. Some of the fluid characteristics you may need include:

- Viscosity
- Grease hardness (NLGI number)
- Specific gravity*
- Surface tension*
- Shear rate
- Corrosiveness
- Abrasiveness
- Solids content
- Formulation (solvent-borne, water-borne)
- Moisture sensitivity
- Curing method
- Specific heat*

*This information may or may not be available. If it is not available, it will seldom impact system design.

Characteristics of the Application

Depending on the application, you will gather different pieces of information from your customer. For example, in an airless spray application, the customer will probably be able to provide you with typical flow rates and pressures they are currently experiencing. In an extrusion application, the customer may tell you the average bead rate and size. You will then need to convert that information into data that you can use to select equipment. Some of the application characteristics you will need include:

- Fluid flow rate (volume)
- Pressure at dispense point or applicator
- Available power source
- Temperature

Customer Priorities

Along with characteristics of the fluid and the application, you need to consider the customer's priorities. For example, some customers may be concerned about the initial cost of the system, while other customers may be willing to spend more initially to keep maintenance and repair costs down in the future. Some priorities you should discuss with your customer include:

- Initial budget
- Maintenance capabilities
- Portability requirements
- Production requirements
- Material conservation

Fluid Containers

Learning Objectives

In addition to the information you gather about the customer's situation, you need to know a few things about the fluid container. Fluids come from material manufacturers in a variety of containers. The containers described in this section fall into four major categories: drums, pails, portable bulk tanks, and bulk containers. Depending on the container size and shape, it may help or hinder the process of getting your customer's fluid into the pump. After completing this section, you will be able to:

- Identify types and sizes of drums and describe how they are commonly used.
- Identify types and sizes of pails and describe how they are commonly used.
- Identify types and sizes of portable bulk tanks and describe how they are commonly used.
- Identify types of bulk containers and describe how they are commonly used.

Drums

The most common types of drums are full removeable head drums (also called open head drums) and tight head drums (also called closed head drums). Drums are either made of a disposable fiber material or are metal and can be recycled. Common sizes include 16, 25, 30, 40, and 55 U. S. gallons. Metric sizes include 60, 90, 114, 150, and 200 liters, as well as 220-liter Canadian. For grease and edible fats, 120-pound (54 kg) and 400-pound (181 kg) drums are common.

Full removeable head (open top) drums are commonly used in applications where the pump and the agitator need to be submersed into a drum of paint. Tight head (closed head) drums are commonly used with low viscosity fluids.

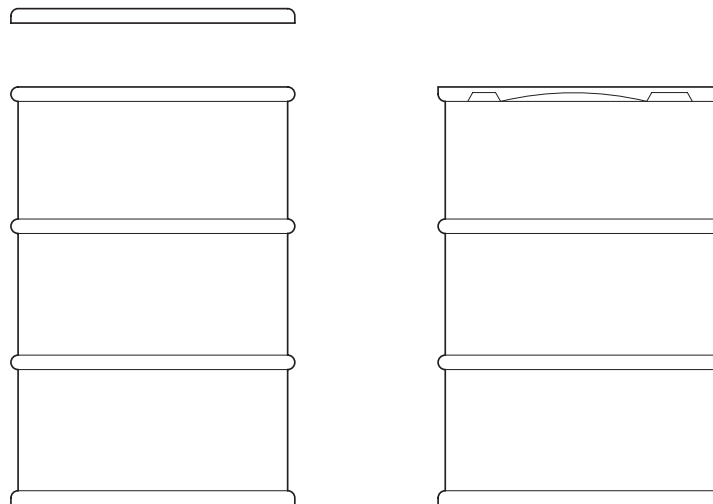

05621

Figure 1: Full removeable head drum (left) and tight head drum (right).

Pails

Both plastic and steel pails are commonly used in a variety of applications. Water-borne paints come in plastic pails and solvent-borne paints come in steel pails. Some pails, usually the plastic ones, are slightly tapered with a larger diameter at the top. This tapering allows the pail manufacturer to stack the pails for easier shipment. Common pail sizes are 5 and 10 U. S. gallons (19 and 38 liter), as well as 20-liter Canadian. Grease pails come in 35-pound (16 kg) and 50-pound (22 kg) sizes.

Portable Bulk Tanks

Portable bulk tanks (also called tote tanks or reusable fluid shipping tanks) come in sizes up to 300 U. S. gallons (1,135 liters). Tote tanks are used in bulk unloading systems. The material supplier ships the material by way of a tank truck or bulk rail car directly to the tote tank at the customer's dispense point. After the customer uses all the material, the tote can be returned to the supplier for refilling.

Bulk material may also be transferred directly from rail care to tank truck to the application point. Or, the fluid may be transferred to totes, drums, or containers as small as a quart or liter.

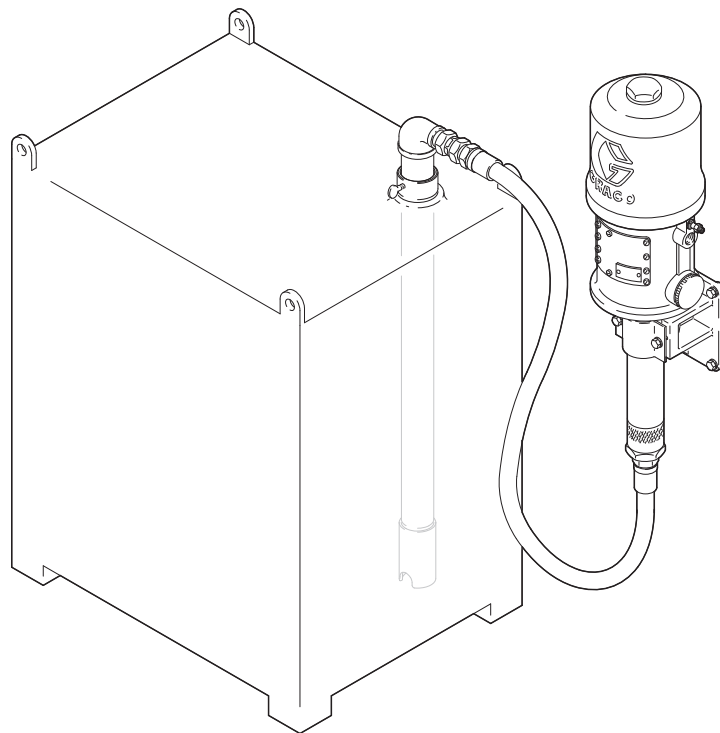

05622

Figure 2: Tote tanks used in bulk unloading systems.

Bulk Containers

Rail cars, above ground tanks, and below ground tanks are all types of bulk containers. Bulk containers are commonly used with high volume usage materials, such as chemicals used in chemical processing applications. Inks, greases, sealants, solvents, and paints may also be moved from bulk containers.

Progress Check

Directions: After answering the following questions, compare your answers with those provided in the answer key following this progress check. If you respond to any items incorrectly, return to the text and review the appropriate topics.

1. Which of the following are fluid characteristics you may want to consider before recommending fluid handling equipment and accessories?
 - a. Viscosity
 - b. Shear rate
 - c. Corrosiveness
 - d. Fluid flow rate
 - e. Solids content
 - f. Temperature
 - g. Moisture sensitivity
 - h. Specific heat

2. List the characteristics of your customer's application you should consider before recommending fluid handling equipment and accessories.

3. Which of the following are potential priorities you should discuss with your customer before recommending fluid handling equipment and accessories?
 - a. Initial budget
 - b. Available power source
 - c. Pressure at dispense point of applicator
 - d. Maintenance capabilities
 - e. Portability requirements
 - f. Fluid formulation, whether solvent-borne or water-borne
 - g. Production requirements
 - h. Material conservation

4. In what types of applications are full removeable head drums commonly used?

5. With what types of fluids are tight head drums commonly used?

6. Which of the following are common pail sizes for fluids or greases?

- a. 5 U. S. gallons (19 liters)
- b. 20 liters
- c. 55 U. S. gallons (200 liters)
- d. 35 pounds (16 kg)
- e. 400 pounds (181 kg)

7. Tote tanks are used in bulk unloading systems.

- a. True
- b. False

8. List some of the materials that may be moved from bulk containers.

Answers to Progress Check

1. a, b, c, e, g, h. Before recommending fluid handling equipment and accessories, you should know as much as possible about the fluid your customer plans to move. Some of the fluid characteristics to consider are viscosity, shear rate, corrosiveness, abrasiveness, solids content, formulation, moisture sensitivity, curing method, and specific heat.
2. Characteristics of your customer's application you should consider before recommending fluid handling equipment and accessories include: fluid flow rate (volume), pressure at dispense point or applicator, available power source, and temperature.
3. a, d, e, g, h. Before recommending fluid handling equipment and accessories, you should discuss with your customers their potential priorities, among which may be their initial budget, maintenance capabilities, portability requirements, production requirements, and material conservation.
4. Full removeable head drums are commonly used in applications where the pump and the agitator need to be submersed into a drum of paint.
5. Tight head drums are commonly used with low viscosity fluids.
6. a, b, d. Common pail sizes are 5 and 10 U. S. gallons (19 and 38 liters), as well as 20-liter Canadian. Grease pails come in 35-pound (16 kg) and 50-pound (22 kg) sizes.
7. True. Tote tanks are used in bulk unloading systems.
8. Inks, greases, sealants, solvents, and paints may all be moved from bulk containers.

Getting the Fluid into the System

Learning Objectives

Once you have all the critical pieces of information about your customer's application and the fluid to be moved, you can begin to look at possible methods for moving the fluid through the system. The easiest way to understand this process is to first look at how to get the fluid from its original container into the system. Both pressure pots and pumps are used to get fluids into a system.

To make learning more convenient, this section contains three major subsections: pressure pots, pump feed issues, and pump feed methods. You will find the learning objectives for each subsection at the beginning of the subsection.

Pressure Pots

After completing this subsection, you will be able to:

- Describe how a pressure pot works.
- Match each component of a pressure pot with its function.
- Differentiate between single regulated and dual regulated pressure pots.
- Recognize situations for which a pressure pot would be an appropriate solution.

How Pressure Pots Work

A pressure pot is a pressurized vessel. For every one pound of air pressure applied to the pressure pot, one pound of fluid pressure is generated (or produced). The pressure created within the tank causes the fluid to flow out of the tank through a hose to the system or the intake of a pump.

Figure 3 illustrates a pressure pot and its key components, including:

- Fluid outlets
- Pressure relief valve
- Bleeder valve
- Clamps
- Tank
- Regulator

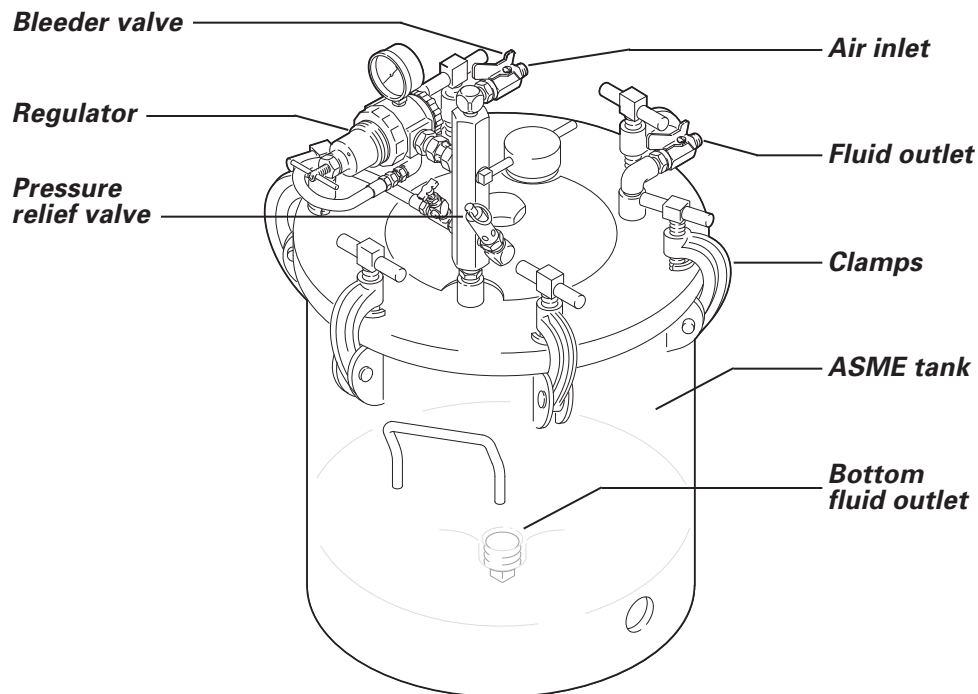

05623

Figure 3: A pressure pot and its key components.

Pressure pots have both a top and a bottom *fluid outlet*. The bottom fluid outlet is often used as a feed supply for highly viscous materials, texture materials, and plural component materials. The bottom outlet is also used for completely emptying a tank.

The *pressure relief valve* automatically relieves air pressure inside the pressure pot to prevent over-pressurization. This over-pressurization may result from a failure in the supply source or regulator, or from temperature variations.

The *bleeder valve* allows you to manually relieve pressure inside the pot before removing the lid.

Clamps help maintain a tight seal between the tank and tank cover.

Both ASME (American Society of Mechanical Engineers) approved and non-ASME approved *tanks* are available. ASME approved tanks are designed to avoid ruptures and come in 2, 5, 10, and 15 U. S. gallons (8, 19, 38 and 57 liters) sizes. Less expensive, non-ASME approved tanks are designed for non-corrosive, lower pressure applications and come in a 2 U. S. gallons (8 liters) size.

The *regulator* controls pressure within the tank.

Types of Pressure Pots

In *single regulated pressure pots* the air pressure regulator controls the outbound fluid pressure only. Single regulated pressure pots may be used:

- With plural component materials as the catalyst supply
- When pumping to a proportioner
- In spray applications along with an existing booth regulator

In *dual regulated pressure pots* one air pressure regulator controls fluid pressure and one air pressure regulator controls atomizing air to a spray gun. Dual regulated pressure pots are commonly used when the air source is a distance from the pressure pot, to allow control of both air and fluid pressure right at the pot.

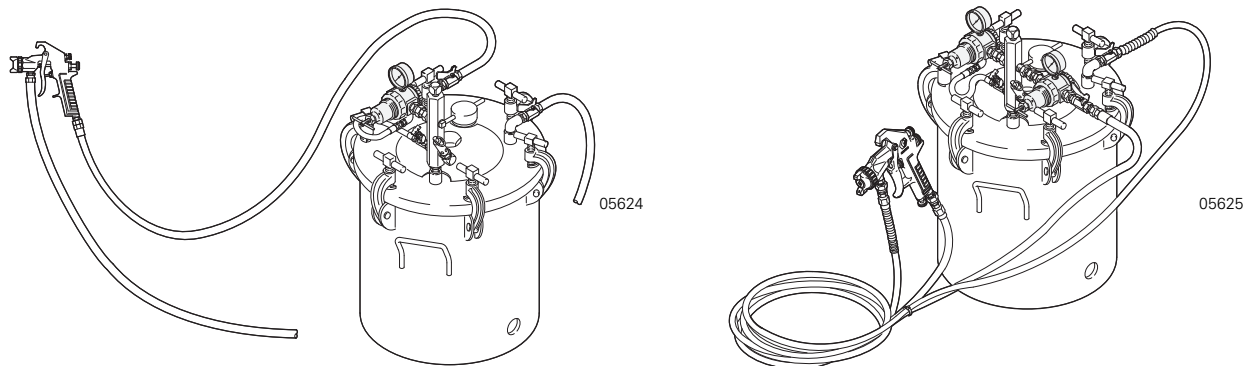

Figure 4: Single regulated pressure pot (left) and dual regulated pressure pot (right).

When to Select a Pressure Pot

Pressure pots are an excellent solution for a number of applications, including:

When long term cost is a concern. Pressure pots require little repair maintenance, resulting in lower long term expense.

In low volume applications. Pressure pots are commonly found in low volume applications such as feeding one or two spray guns in an air spray application. Low volume may be better described by the amount of fluid used in an 8-hour day. Pressure pots would be appropriate for applications that require refilling every two or three days.

In multiple color applications. For small quantities, a pail is set right inside the pot for easy clean up.

With moisture-sensitive or oxygen-sensitive materials. The self-contained environment of a pressure pot may be a better selection for moisture sensitive materials such as isocyanate.

For degas/isolation applications. A pressure pot can be used as a vacuum tank when the customer needs all the air pulled out of the material for precision mixing.

As a low pressure feed supply. In applications where the fluid pressure must be very low, pressure can often be controlled more accurately with a pressure pot than with a pump and fluid regulator.

For fine finish applications. A pressure pot can provide pulse-free fluid delivery when a pulsating reciprocating pump is not acceptable.

Pressure pots are also a good solution in applications where portability is not a priority and when agitation is required in a small, sealed system.

Progress Check

Directions: After answering the following questions, compare your answers with those provided in the answer key following this progress check. If you respond to any items incorrectly, return to the text and review the appropriate topics.

1. Describe how a pressure pot works.

For items 2 through 6, match the pressure pot component with its description:

Component

- a. Bottom fluid outlet
- b. Pressure relief valve
- c. Bleeder valve
- d. Clamps
- e. Regulator

Description

- ___ 2. Automatically relieves pressure inside the pressure pot to prevent over-pressurization.
- ___ 3. Help maintain a tight seal between the tank and the lid.
- ___ 4. Allows you to manually relieve pressure inside the pot before removing the lid.
- ___ 5. Controls pressure within the tank.
- ___ 6. Often used as a feed supply for highly viscous materials, texture materials, and plural component materials.

7. What does the air pressure regulator in a single regulated pressure pot control?

8. Dual regulated pressure pots have two air pressure regulators. What do each of these regulators control?

9. Select the applications for which a pressure pot would be a good solution:

- a. When long term cost is a concern
- b. In high volume applications
- c. In multiple color applications using small quantities of color
- d. With moisture- or oxygen-sensitive materials
- e. For degas/isolation applications
- f. As a high pressure feed supply
- g. For fine finish applications when a pulsating reciprocating pump is not acceptable
- h. Where portability is not a priority

Answers to Progress Check

1. A pressure pot is a pressurized vessel. For every one pound of air pressure applied to the pressure pot, one pound of fluid pressure is generated (or produced). The pressure created within the tank causes the fluid to flow out of the tank through a hose to the system or intake of a pump.
2. b. The pressure relief valve automatically relieves pressure inside the pressure pot to prevent over-pressurization.
3. d. Clamps help maintain a tight seal between the tank and the lid.
4. c. The bleeder valve allows you to manually relieve pressure inside the pot before removing the lid.
5. e. The regulator controls pressure within the tank.
6. a. The bottom fluid outlet is often used as a feed supply for highly viscous materials, texture materials, and plural component materials.
7. The air pressure regulator in a single regulated pressure pot controls the outbound fluid pressure only.
8. In dual regulated pressure pots one air pressure regulator controls fluid pressure and one air pressure regulator controls atomizing air to spray gun.
9. a, c, d, e, g, h. Pressure pots are an excellent solution for a number of applications, including: when long term cost is a concern, in low volume applications, in multiple color applications using small quantities of color, with moisture- or oxygen-sensitive materials, for degas/isolation applications, as a low pressure feed supply, for some fine finish applications, where portability is not a priority, when agitation is required in a small, sealed system.

Pump Selection

Based on the customer situation and the items just discussed in the pressure pot section, you will know whether to eliminate a pressure pot as a possible method for moving a fluid through the system. If a pressure pot is eliminated as a possible solution, you can assume you will move the fluid with a pump. Your job is then to select a pump.

Pump selection is not covered in this module. However, several modules are available to help you with this task, including: *Two-Check Pumps, Four-Check Pumps, Priming Piston Pumps, Double Diaphragm Pumps, Plunger Pumps, and Pump Selection.*

Pump Feed Issues

Once you have selected a pump, your job is to select a *pump feed method*, a method for getting the fluid into the pump. There are a number of methods available to feed a pump; it is your job to help select the best feed method for your customer's specific situation. We will discuss each feed method in detail, but first we need to learn some basic issues that impact selecting a pump feed method. After completing this subsection, you will be able to:

- Define positive fluid pressure and explain why it is required to load a reciprocating piston pump.
- Explain cavitation and how to avoid it.
- Describe suction lift loss and use it to help calculate whether positive or negative pressure exists in a system.
- Define vapor pressure and give an example of the types of fluids for which it is a concern.
- Explain the importance of pressure differential when selecting a feed method.

Loading a Piston Pump

No matter what feed method we use, our purpose is to load the pump. In this section, we will assume that our goal is to load a *reciprocating piston pump*. To load a reciprocating piston pump you need a positive supply of fluid to the pump inlet, also known as *positive fluid pressure*. Positive fluid pressure is a condition in which the pressure on the outside of the pump inlet is greater than the internal pressure of the pump during upstroke. That positive fluid pressure forces material into the pump intake.

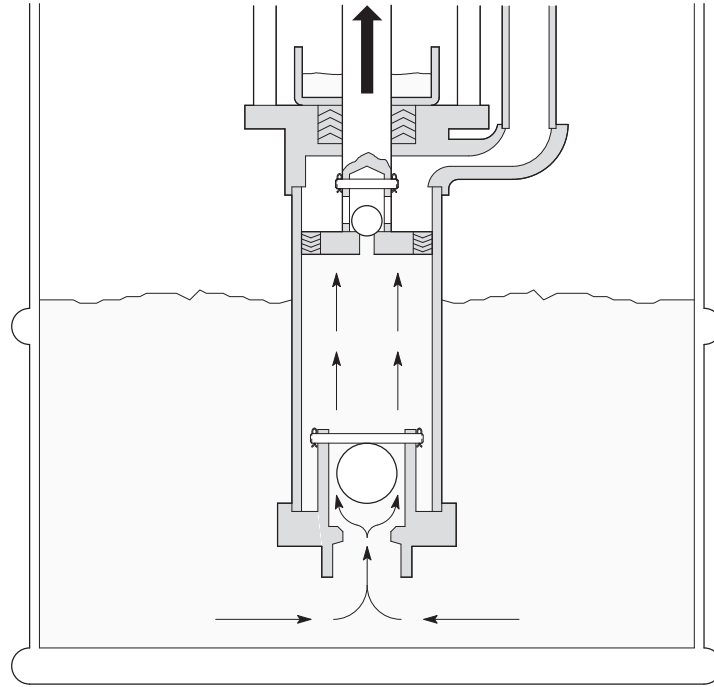

04538

Figure 5: A positive supply of fluid (positive fluid pressure) is required to load a reciprocating piston pump.

A pump's fluid output is determined by how fast the positive fluid pressure can force the fluid into the pump cavity. The pump cavity must be 100 percent full during every cycle. If the pump cavity is not 100 percent full, the restriction will cause a condition called *cavitation*. Cavitation is when the pump creates a vacuum (negative pressure) on the fluid. At this point, the pump draws a gas instead of a liquid, or creates a void if the fluid is viscous. When a void develops in the pump cavity, the result is pump diving and inconsistent pressure and flow. The way to avoid cavitation is to make sure you have positive fluid pressure at the pump inlet.

Suction Lift Loss

To ensure that you have positive fluid pressure entering the pump, you need to understand the concept of *suction lift loss*. Total suction lift loss takes into consideration both frictional pressure loss (due to restriction caused by pipe, hose, or tubing) and vertical pressure loss (due to the weight of the fluid). A simple formula will help you calculate total suction lift loss and determine whether you have a positive or negative pressure situation. It is critical to evaluate suction lift loss when siphon feeding a pump.

Formula

$$\begin{array}{rcl} \text{Step One} & & \text{Frictional pressure loss} \\ & + & \text{Vertical pressure loss} \\ & \hline & = & \text{Total suction lift loss} \\ \\ \text{Step Two} & & \text{Atmospheric pressure available} \\ & - & \text{Total suction lift loss} \\ & \hline & = & \text{Pressure (result can be either positive or negative)} \end{array}$$

Example

Your customer wants to siphon feed a fluid from a 55-gallon (200 liter) drum. The lift distance is 3 feet (1 meter). Atmospheric pressure available to load the pump is 12 psi (.83 bar). Frictional pressure loss is 9 psi (.62 bar) and vertical pressure loss is 1.32 psi (.09 bar).

$$\begin{array}{rcl} \text{Step One} & & 9.0 \text{ psi } (.62 \text{ bar}) \text{ frictional pressure loss} \\ & + & 1.32 \text{ psi } (.09 \text{ bar}) \text{ vertical pressure loss} \\ & \hline & = & 10.32 \text{ psi } (.71 \text{ bar}) \text{ total suction lift loss} \\ \\ \text{Step Two} & & 12.0 \text{ psi } (.83 \text{ bar}) \text{ atmospheric pressure available} \\ & - & 10.32 \text{ psi } (.71 \text{ bar}) \text{ total suction lift loss} \\ & \hline & = & 1.7 \text{ psi } (.12 \text{ bar}) \text{ positive pressure} \end{array}$$

Since 1.7 psi (.12 bar) positive pressure is available, siphon feed is an acceptable feed method for your customer.

Vapor Pressure

Vapor pressure is the pressure required to keep a fluid in a liquid state before it turns into a gas. Since gases cannot be pumped by Graco equipment, vapor pressure is a concern when pumping volatile liquids or fast evaporating solvents. If the pressure available to prime the pump drops below the vapor pressure of the liquid, the pump will draw a gas instead of the liquid. This will result in cavitation, or a total inability to pump the liquid.

In theory, to determine if you can pump a liquid you must first add your vertical pressure loss and frictional pressure loss to determine total pressure loss. Then, subtract total pressure loss from the atmospheric pressure that is available to load the pump. If the result is less than the vapor pressure of the liquid, you cannot prime the pump.

Example

Your customer wants to siphon feed a fluid from a 55-gallon (200-liter) drum. The lift distance is 3 feet (1 meter). Atmospheric pressure available to load the pump is 12 psi (.83 bar). The vapor pressure of the fluid is 6 psi (.41 bar). Frictional pressure loss is 7 psi (.48 bar) and vertical pressure loss is 1.4 psi (.09 bar).

$$\begin{array}{rcl} \text{Step One} & & 7.0 \text{ psi } (.48 \text{ bar}) \text{ frictional pressure loss} \\ & + & 1.4 \text{ psi } (.09 \text{ bar}) \text{ vertical pressure loss} \\ & \hline & = & 8.4 \text{ psi } (.57 \text{ bar}) \text{ total pressure loss} \end{array}$$

$$\begin{array}{rcl} \text{Step Two} & & 12.0 \text{ psi } (.83 \text{ bar}) \text{ atmospheric pressure} \\ & - & 8.4 \text{ psi } (.57 \text{ bar}) \text{ total pressure loss} \\ & \hline & = & 3.6 \text{ psi } (.26 \text{ bar}) \text{ available pressure} \end{array}$$

$$\begin{array}{rcl} \text{Step Three} & & 3.6 \text{ psi } (.26 \text{ bar}) \text{ available pressure} \\ & - & 6.0 \text{ psi } (.41 \text{ bar}) \text{ vapor pressure of liquid} \\ & \hline & = & -2.4 \text{ psi } (-.15 \text{ bar}) \end{array}$$

Since the available pressure is less than the vapor pressure of the liquid, you cannot siphon feed this fluid in this application. You will have to feed the pump by a method with less pressure loss between the fluid container and the pump.

Vapor Pressure Recommendation

To prevent potential priming and loading problems due to vapor pressure loss, Graco recommends that siphon feed be used only when available pressure exceeds vapor pressure by 5 psi (.34 bar) or more. If vapor pressure is not known, available pressure should be equal to or greater than 8 psi (.6 bar) after subtracting vertical and frictional pressure loss.

Pressure Differential: A Warning

The term *pressure differential* is an important one as you go through the process of selecting a feed method. The pressure differential tells you the total pressure available to get a fluid into a pump. Without that information, you may recommend the wrong feed method. Because it is easy to underestimate all the factors that go into determining total pressure loss in a system and because customer situations may change, make sure you check and double-check all your information and calculations before selecting a feed method.

Example

Imagine that you have a long water hose from the fluid container to the inlet of the pump and 40 psi (2.76 bar) pressure available to feed the pump. As you move through the hose the pressure drop is 50 psi (3.4 bar). By the time you get to the end of the hose, the result is -10 psi (-.68 bar).

This example illustrates that, if your inlet hose is too long, the pressure drop through the hose will result in negative pressure at the pump inlet and you risk pump cavitation. A solution to this problem would be to use a shorter hose, a larger diameter hose, or to use a feed pump.

The most common factors that adversely affect feed pressure loss include: high viscosity materials and a suction hose that is either too long and/or has too small an inside diameter.

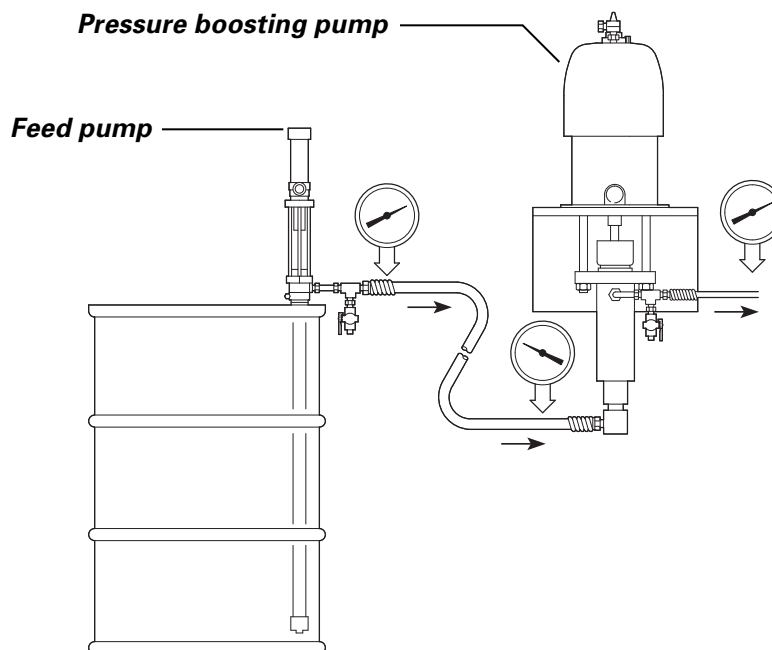

05626

Figure 6: A shorter suction hose, a larger diameter suction hose, or a feed pump (illustrated here) can help increase fluid pressure at the pump inlet.

Progress Check

Directions: After answering the following questions, compare your answers with those provided in the answer key following this progress check. If you respond to any items incorrectly, return to the text and review the appropriate topics.

1. Describe *positive fluid pressure*.

2. Explain the term *cavitation*.

3. Your customer wants to siphon feed a fluid from a 55-gallon (200 liter) drum. The lift distance is 3 feet (1 meter). Frictional pressure loss is 9 psi (.62 bar) and vertical pressure loss is 1.32 psi (.09 bar). Atmospheric pressure available to load the pump is 12 psi (.83 bar). Use the suction lift loss formula provided to calculate whether this is a positive or negative pressure situation.
- a. Positive pressure
 - b. Negative pressure

Step 1

$$\begin{array}{r} \text{Frictional pressure loss} \\ + \text{ Vertical pressure loss} \\ \hline = \text{ Total suction lift loss} \end{array}$$

Step 2

$$\begin{array}{r} \text{Atmospheric pressure available} \\ - \text{ Total suction lift loss} \\ \hline = \text{ Pressure (result can be either} \\ \text{positive or negative)} \end{array}$$

4. Define vapor pressure and give an example of the types of fluids for which it is a concern.

5. Why is pressure differential important when selecting a feed method?

Answers to Progress Check

1. To load a reciprocating piston pump you need a positive supply of fluid to the pump inlet, also known as *positive fluid pressure*. Positive fluid pressure is a condition in which the pressure on the outside of the pump inlet is greater than the internal pressure of the pump during upstroke. That positive fluid pressure forces material into the pump intake.
2. A pump cavity must be 100 percent full during every cycle. If the pump cavity is not 100 percent full, a restriction will cause a condition called *cavitation*. Cavitation is when the pump creates a vacuum (negative pressure) on the fluid. At this point, the pump draws a gas instead of a liquid, or creates a void if the fluid is viscous. When a void develops in the pump cavity, the result is inconsistent pressure and flow.
3. a. The application described is a positive pressure situation. Calculations are:

Step 1

$$\begin{array}{r} 9 \text{ psi (.62 bar) frictional pressure loss} \\ + 1.32 \text{ psi (.09 bar) vertical pressure loss} \\ \hline = 10.32 \text{ psi (.71 bar) total suction lift loss} \end{array}$$

Step 2

$$\begin{array}{r} 12 \text{ psi (.83 bar) atmospheric pressure available} \\ - 10.32 \text{ psi (.71 bar) total suction lift loss} \\ \hline = 1.7 \text{ psi (.12 bar) positive pressure} \end{array}$$

4. *Vapor pressure* is the pressure required to keep a fluid in a liquid state before it turns into a gas. Since gases cannot be pumped, vapor pressure is a concern when pumping volatile liquids or fast evaporating solvents.
5. The *pressure differential* tells you the total pressure available to get a fluid into a pump. Without that information, you may recommend the wrong feed method. Because it is easy to underestimate all the factors that go into determining total pressure loss in a system and because customer situations may change, make sure you check and double-check all your information and calculations before selecting a feed method.

Pump Feed Methods

As mentioned previously, once you have selected a pump your task is to select the appropriate feed method for that pump and for your customer's specific application. The fluid to be moved, the type of application, and your customer's priorities will help narrow the choices. Categories of pump feed methods we discuss in this subsection include: siphon feed, gravity feed, submersion feed, immersion feed, and pressure feed. After completing this subsection, you will be able to:

- Describe siphon feed and indicate fluids and applications for which siphon feed is an appropriate feed method.
- Describe gravity feed and indicate fluids and applications for which gravity feed is an appropriate feed method.
- Describe submersion feed and indicate fluids and applications for which submersion feed is an appropriate feed method.
- Describe immersion feed and indicate fluids and applications for which immersion feed is an appropriate feed method.
- Explain the function of a follower plate.
- Describe pressure feed and indicate fluids and applications for which pressure feed is an appropriate feed method.
- Define the 25 percent pressure feed rule and where it is applicable.
- Describe an inductor system and indicate fluids and applications for which an inductor system is an appropriate feed method.
- Describe a ram system and indicate fluids and applications for which a ram system is an appropriate feed method.
- Match feed methods with their approximate fluid viscosity range.
- Explain the advantages of bulk unloading systems.

Siphon Feed

Customers often request siphon feeding because it is a relatively simple and low cost pump feed method. In siphon feeding, atmospheric pressure pushes the fluid through a hose from the fluid container into the pump.

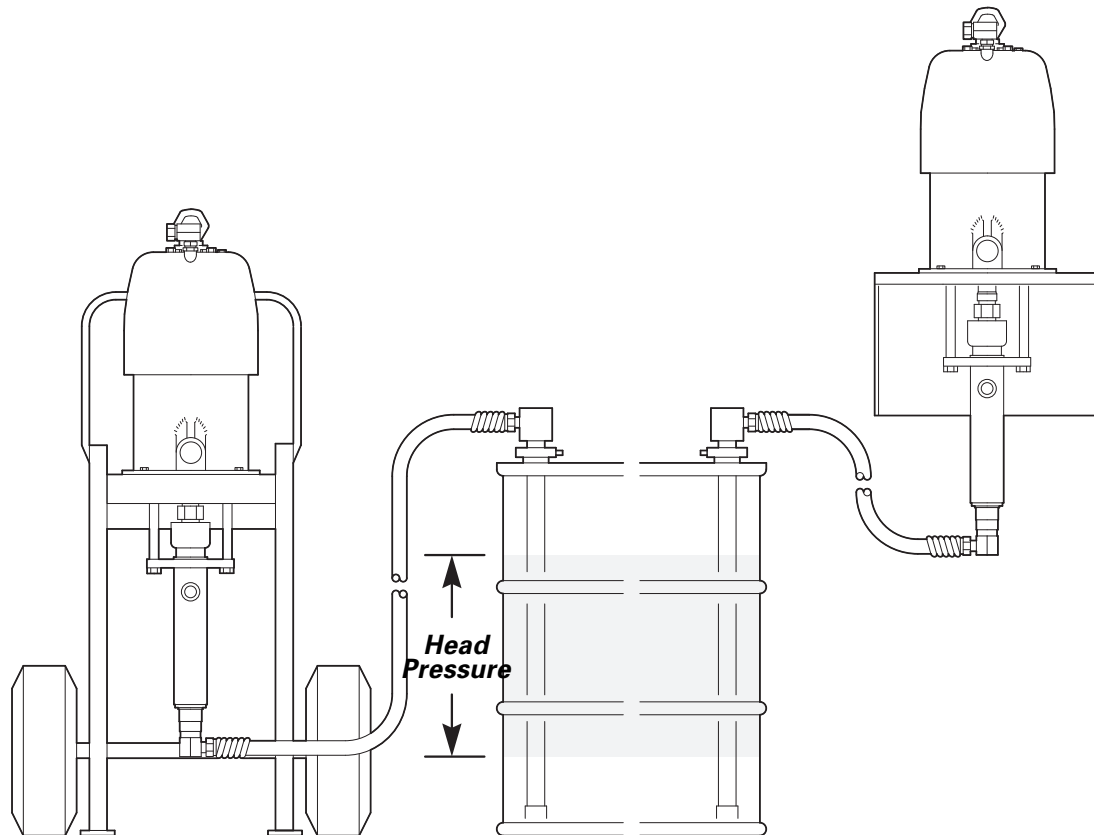

05627

Figure 7: Two types of siphon feed systems: siphon feed with benefit of head pressure (left) standard (right).

Siphon feeding is a good solution for moving fluids of up to 5,000 cp that flow easily. Siphon feeding works well when pumping from a closed head drum, when agitation requirements dictate large blades that do not allow the pump to be in the container, and when your customer prefers a wall mount.

It is important to remember that a long siphon hose or a small diameter siphon hose can make it more difficult to feed a pump, due to greater pressure loss. When considering siphon feeding, be sure to evaluate vertical pressure loss, vapor pressure loss, and especially frictional pressure loss.

Gravity Feed

Gravity feeding is another popular feed method. In gravity feeding, the only pressure being applied is atmospheric pressure and the weight of the fluid. Typically, the fluid flows through the bottom of the container to the pump intake, which is below the fluid level.

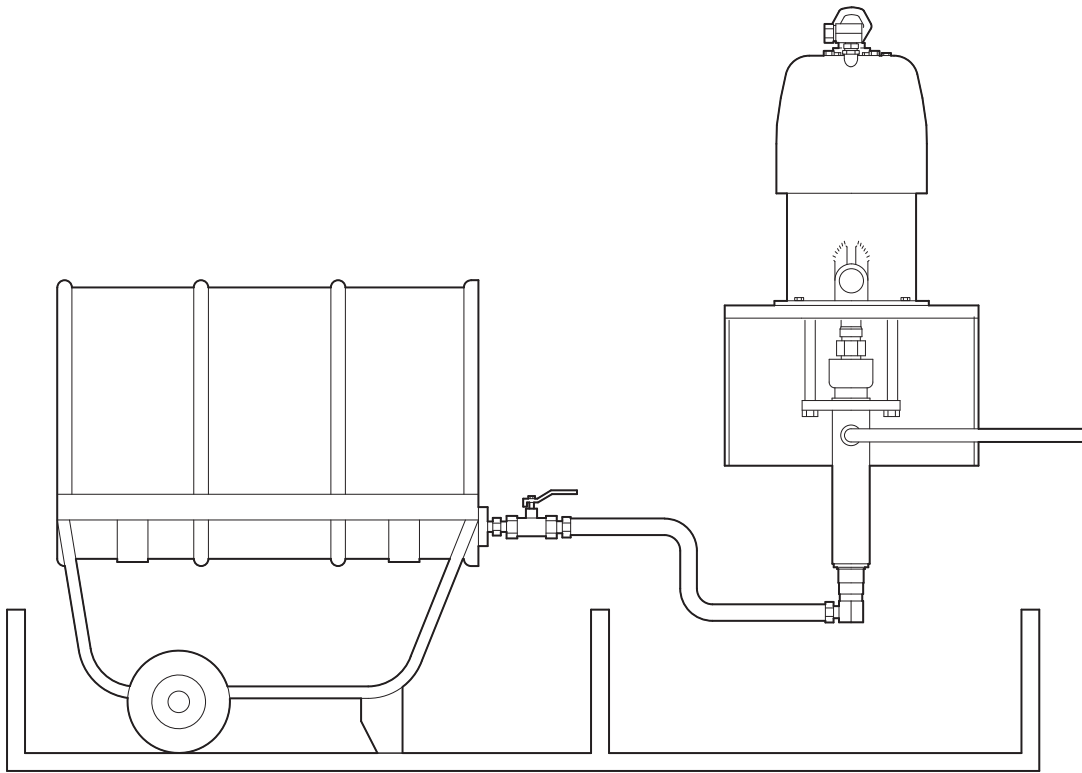

05628

Figure 8: Gravity feed system inside containment barrier.

Gravity feeding works well with fluids that flow easily and have viscosities of up to 5,000 cp. Gravity feeding is common in permanent tank installations and bulk tote tank installations.

When designing a gravity feed system, be sure to size fluid hose or pipe and fittings carefully. Remember that a restricted pump inlet can cause cavitation.

Submersion Feed

In a submersion feed system, as illustrated in Figure 9, the pump is completely submerged below the fluid level.

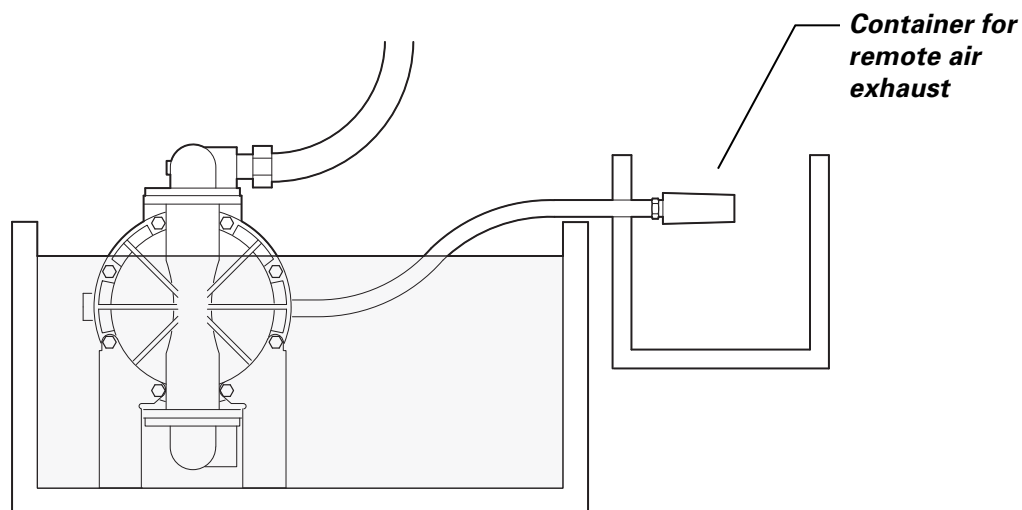

05629

Figure 9: Submersion feed system.

Submersion feeding is used with fluids that range in viscosity from 5,000 to 20,000 cp like maintenance fluids and water waste products, and in de-watering applications. Materials that are too viscous will not load properly.

Diaphragm pumps are the most common type of pump used in submersion feed systems.

Immersion Feed

In immersion feed systems, an extension helps immerse the pump foot valve in the fluid. Bung and cover mounted pumps are commonly used in immersion feeding.

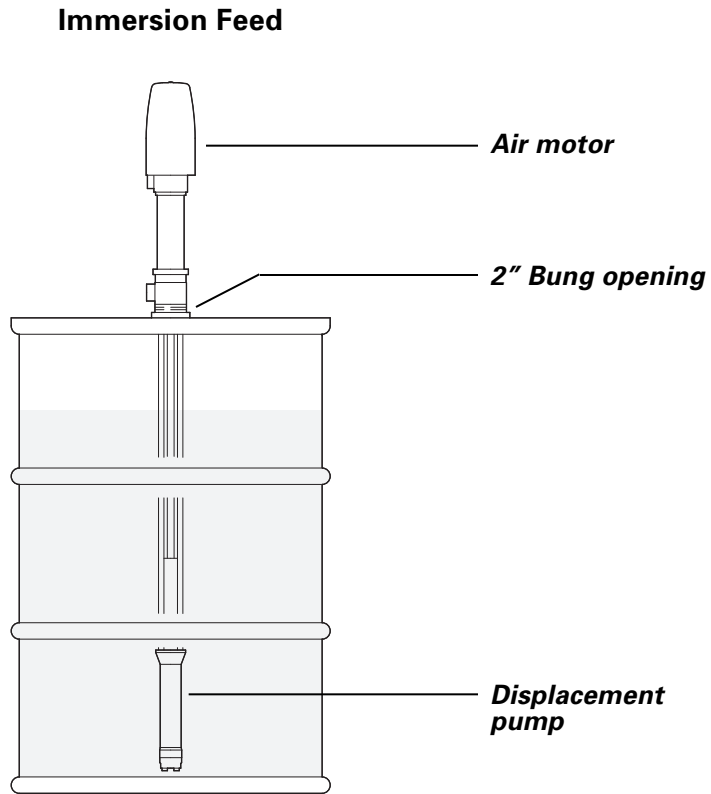

05630

Figure 10: Immersion feed system.

Immersion feeding can be used to load fluids that flow easily, such as paints, oils, and block fillers with viscosities between 5,000 and 20,000 cp. Immersion feeding is commonly used to pump materials from the original shipping container, where the pump can be set into the the 2-inch bung opening.

Since the flow path to the pump inlet is short and offers little resistance to flow, immersion feeding is a very efficient method for feeding a pump. Be sure the outside of the pump housing is compatible with the material being pumped, as well as the usual wetted parts with the material being pumped.

Follower plates are used in immersion feed systems with highly viscous materials (15,000 to 50,000 cp), such as greases in the lubrication industry. The heavy plate floats on the surface of the material to be pumped. Positive fluid pressure results from the pressure differential (atmospheric pressure on top of the plate and a vacuum under the plate).

The follower plate must seal around the exterior surface of the pump tube and the inner surface of the container to be effective. The plate prevents the fluid from *channeling*. An example of channeling is when a knife cuts through a product like mayonnaise and creates an air pocket. (In grease applications, the channels collapse and form air pockets. The air pockets are drawn into the pump, causing cavitation.) The plate also helps isolate the material from contaminants.

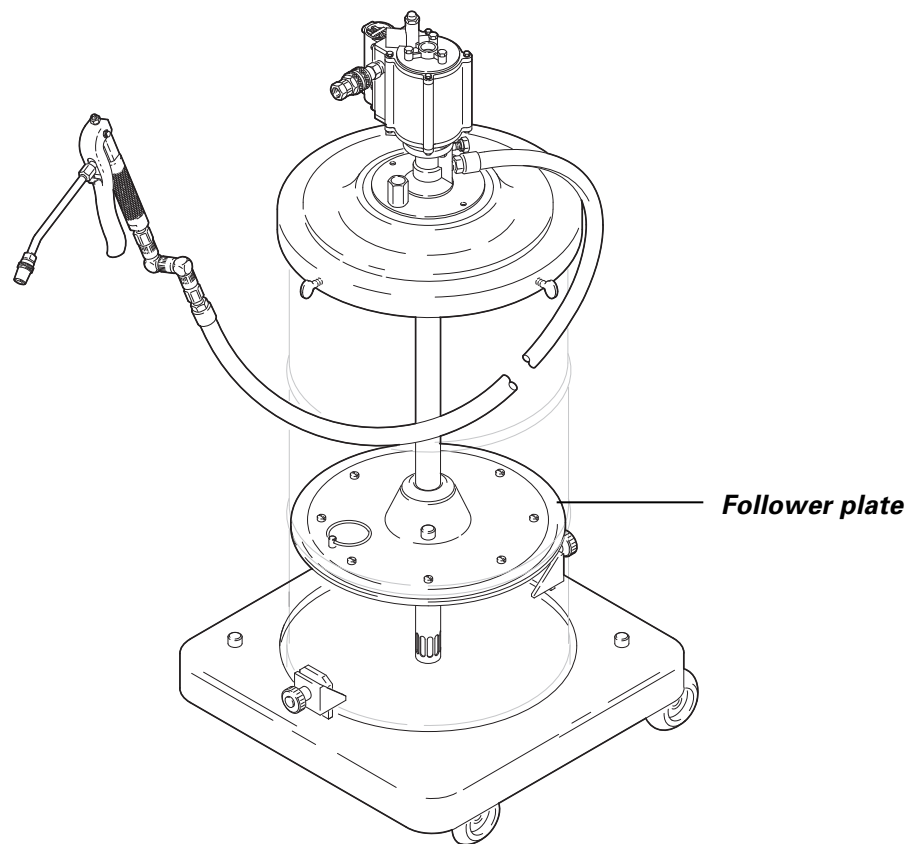

05631

Figure 11: Follower plates are used in immersion feed systems with highly viscous materials.

Pressure Feed

Pressure feeding uses one pump, or another pressure feed source, to feed another pump. Pressure feeding is common with fluids of medium to heavy viscosity, ranging from 5,000 to 150,000 cp. An example of a typical pressure feed application is a 5:1 ratio pump feeding a proportioner, similar to the system illustrated in Figure 12.

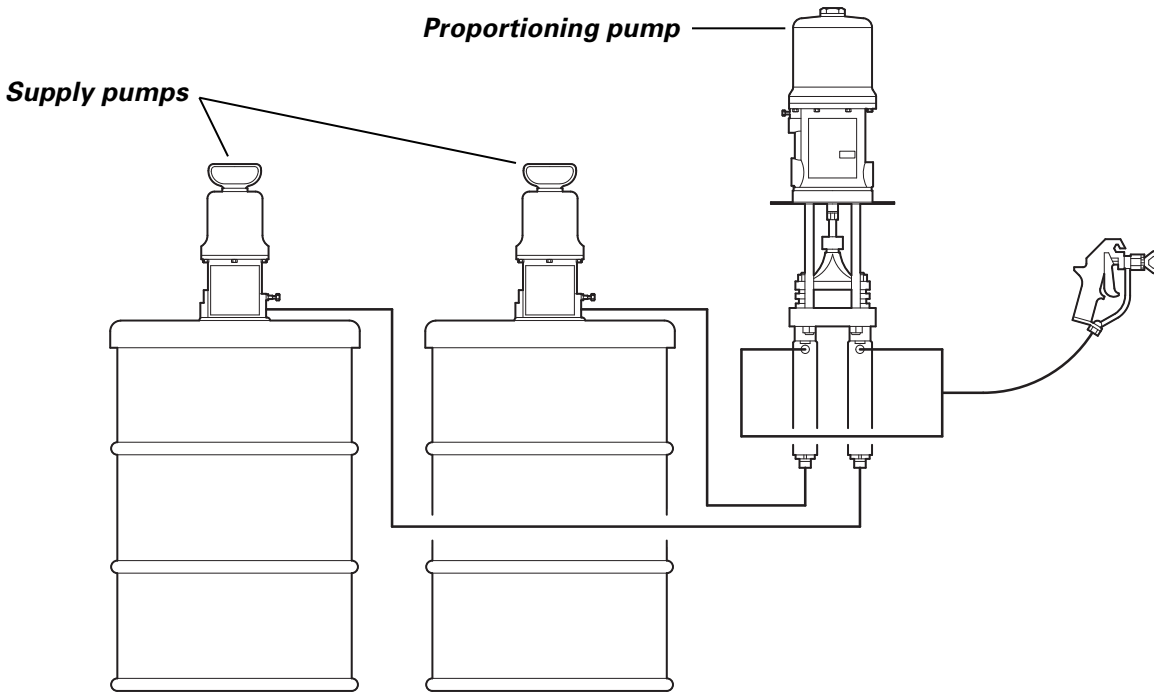

05632

Figure 12: Typical pressure feed system: 5:1 ratio pump feeding a proportioner.

When designing a pressure feed system, it is important to keep in mind the *25 percent pressure feed rule*. This rule says that the feed supply pressure should not exceed 25 percent of the output fluid pressure of the piston pump being fed. You need enough pressure to supply the proper volume to the pump. The goal is to load the pump 100 percent on the upstroke.

(Important! The 25 percent pressure feed rule does not apply to diaphragm pumps or Glutton pumps. These pumps can be damaged with that amount of feed pressure.)

Figure 13 illustrates an example where the output pressure of a proportioning pump cylinder is 2000 psi (138 bar). 25 percent of 2000 psi (138 bar) is 500 psi (34.5 bar). If pressure in the pump being fed is more than 500 psi (34.5 bar), the pump's foot valve will not operate properly and can cause an off-ratio situation in a plural component application. The excess pressure can also cause unusual wear on the pump packings. If the pressure in the pump being fed is significantly less than 500 psi (34.5 bar), again the application can become off ratio due to insufficient loading of material. (Note that this is only if the supply pressure becomes negative.)

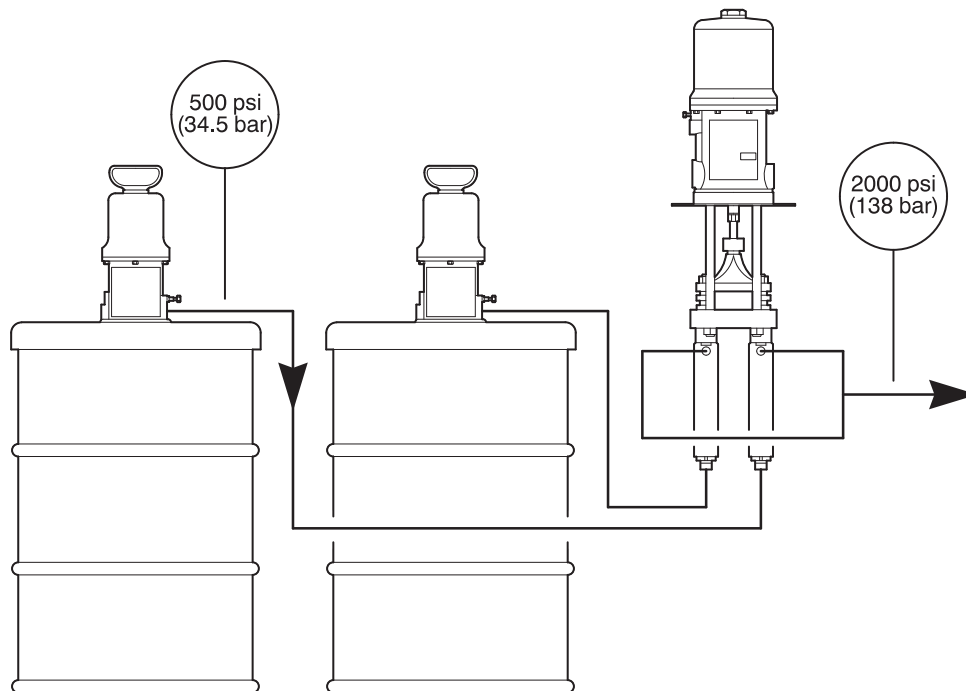

05633

Figure 13: Illustration of 25 percent pressure feed rule, which says that the feed supply pressure should not exceed 25 percent of the output fluid pressure of the piston pump being fed.

There are some situations for which the 25 percent rule may not be appropriate. One example of a situation where it may not be appropriate is when a ram system is used to move a very viscous material. (Ram systems are described later in this module). With heavier viscosity materials, rather than using the 25 percent rule, you may need to use the viscosity of the material and the down force of the ram to calculate the output pressure of your proportioning pump. Or, you could use a higher or lower pressure to create a pressure balance within the system to compensate for different viscosities.

Variations of Pressure Feed

Inductor systems and ram systems are variations of a standard pressure feed system.

An *inductor system* (illustrated in Figure 14) consists of a pump, motor, inductor plate, pneumatic elevator, and stand. The atmospheric pressure on the inductor plate, along with the weight of the plate and the pump, help load and prime the pump.

Inductors are commonly used to move viscous industrial fluids, from 20,000 to 100,000 cp, that flow slowly. You will find inductors used to move food products (like mayonnaise) and greases in low temperature applications. Inductor systems commonly pump materials from their original shipping containers.

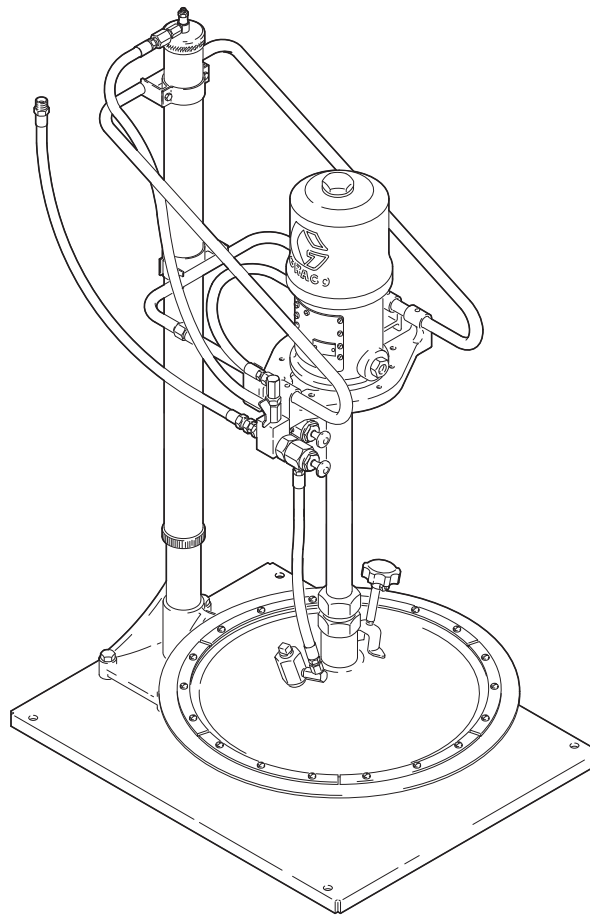

05634

Figure 14: An inductor system is a type of pressure feed system used to move viscous industrial fluids.

A *ram system* (illustrated in Figure 15) consists of a pump, motor, ram plate, hydraulic or pneumatic ram, and stand. The atmospheric pressure on the ram plate, the weight of the plate and pump, and the down force from one or more ram cylinders prime and load the pump. One-, two-, and four-post ram configurations are commonly available.

Rams can move viscous industrial fluids that do not flow easily, from 100,000 to 6,000,000 cp. (For fluids of more than 3,000,000 cp, you should always call Graco Technical Assistance at 1-800-543-0339 before making a feed method recommendation.) One-part silicones are moved with rams. Very heavy greases that need to be pumped in cold weather may also require a ram system to prevent cavitation.

Heated ram plates (also known as *platens*) are used to pump certain types of materials that must be heated to reduce the viscosity so they can flow and be pumped at the available pressure. Heated ram plates may also be used to melt a material from a solid to a liquid.

Pneumatic rams provide the additional pressure often required due to heavier viscosities. An example of this might be when a high-viscosity silicone from a 55-gallon drum is used to fill tubes for caulking guns.

Hydraulic rams develop higher down pressure than pneumatic rams and are used when additional power is required to load the pump. Hydraulic rams are commonly used with extremely viscous materials such as butyls with viscosities over 3,000,000 cp.

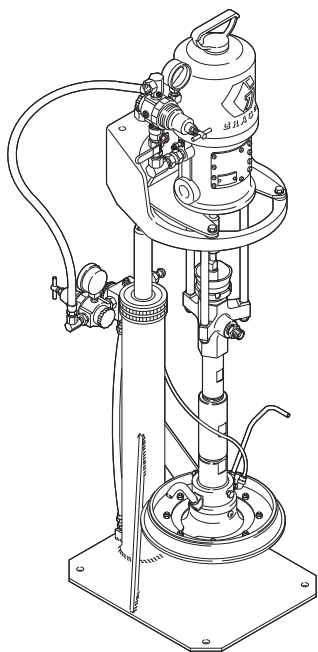

05635

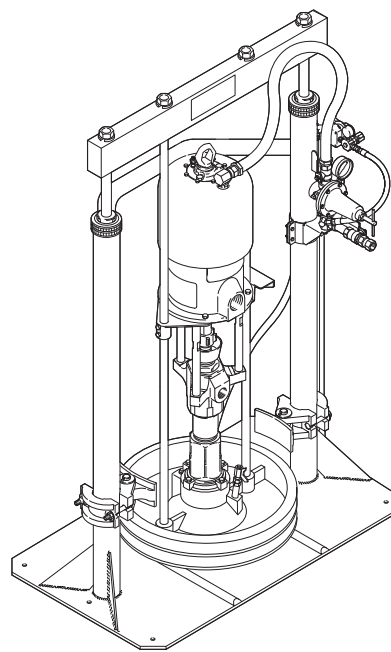

05636

Figure 15: A ram system is a type of pressure feed system used to move very viscous industrial fluids. Pictured here are a one-post ram (left) and a two-post ram (right).

Use following chart as a quick reference to help you narrow your choice of feed methods based on the viscosity of the fluid your customer wants to move:

Feed Methods and Viscosity Summary Chart	
Feed Method	Approximate Viscosity Range
Siphon	up to 5,000 cp
Gravity	up to 20,000 cp
Submersion	up to 5,000 cp
Immersion	5,000 to 20,000 cp
Follower Plates	15,000 to 50,000 cp
Pressure	5,000 to 150,000 cp
Inductors	20,000 to 100,000 cp
Rams	100,000 to 6,000,000 cp

Figure 16: Ranges provided in this chart are for Newtonian-type fluids. Non-Newtonian fluids may react differently.

Bulk Unloading Systems

Bulk unloading systems offer customers cost savings and efficiency. Due to lower cost of materials purchased in bulk and higher container disposal costs, the numbers of customers using these systems continually rises. Bulk unloading systems move greases, food products, sealants and adhesives, and inks. Automotive assembly plants, printing plants, and large commercial packaging plants all use bulk systems.

An example of a bulk unloading system is a “Bag in a Box Evacuation System” (BES), illustrated in Figure 17. The systems also use Uni-drums and funnel-bottomed tote tanks. Since tote tanks are reusable, the customer’s container disposal costs are reduced.

While bulk unloading systems are popular with many customers, you need to be aware of a few issues related to these systems:

- For viscous materials, you will need a self-priming pump.
- You need large supply hoses, especially when gravity feeding.
- With greases, you may need to manually fill and prime the hose and stand.

“Bag in a Box Evacuation System”

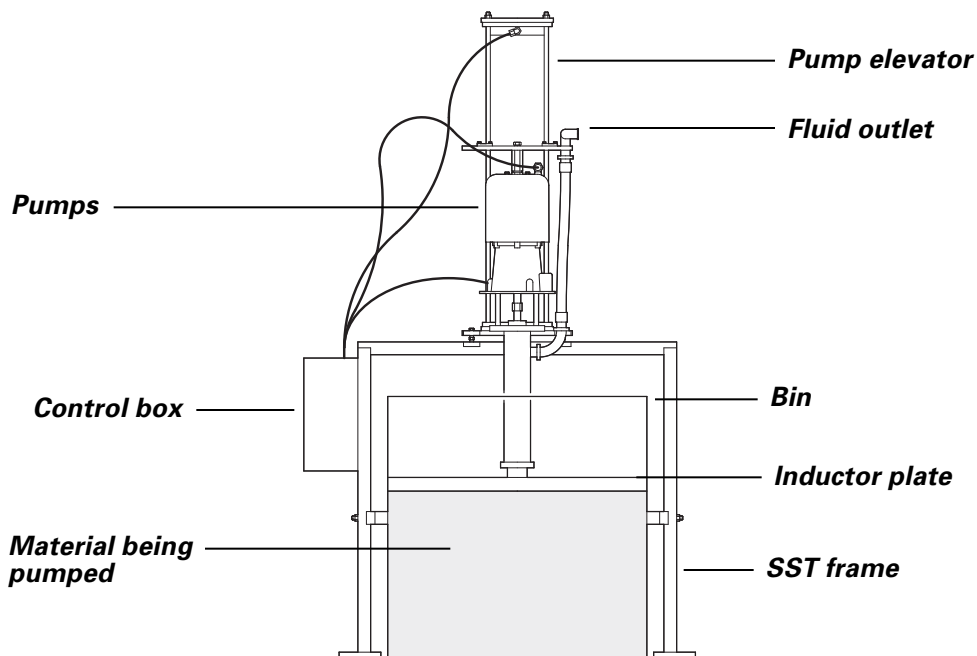

05637

Figure 17: An example of a bulk unloading system.

Progress Check

Directions: After answering the following questions, compare your answers with those provided in the answer key following this progress check. If you respond to any items incorrectly, return to the text and review the appropriate topics.

For items 1 through 5, match the feed method with its description.

Feed Method

- a. Siphon feed
- b. Gravity feed
- c. Submersion feed
- d. Immersion feed
- e. Pressure feed

Description

- ___ 1. With this feed method, the only pressure being applied is atmospheric pressure and the weight of the fluid. This feed method works well with fluids that flow easily and have viscosities of up to 5,000 cp. It is common in permanent tank installations and bulk tote tank installations.
- ___ 2. This feed method uses one pump, or another pressure feed source, to feed another pump. It is common with fluids of medium to heavy viscosity, ranging from 5,000 to 150,000 cp.
- ___ 3. This feed method is used with fluids that range in viscosity from 5,000 to 20,000 cp, like maintenance fluids and water waste products. Materials that are too viscous will not load well with this feed method. Diaphragm pumps are the most common type of pumps used with this feed method
- ___ 4. This feed method is used to load fluids that flow easily, such as paints, oils, and block fillers with viscosities between 5,000 and 20,000 cp. It is commonly used to pump materials from the original shipping container. Bung and cover mounted pumps are typical with this feed method.
- ___ 5. With this feed method, atmospheric pressure pushes the fluid from the top of the fluid container through a hose, into the pump. It is a good method for moving fluids of up to 5,000 cp that flow easily. This feed method works well when pumping from a closed head drum, when agitation requirements dictate large blades that do not allow the pump to be in the container, and when your customer prefers a wall mount.

6. For what types of material or application would you recommend a follower plate to a customer using immersion feeding?

7. State the 25 percent pressure feed rule.

8. An inductor system and a ram system are both variations of a standard pressure feed system. For what types of materials or applications would you recommend an inductor system? For what types of materials or applications would you recommend a ram system?

9. Complete the missing information in this chart.

Feed Methods and Viscosity Summary Chart	
Feed Method	Approximate Viscosity Range
Siphon	up to 5,000 cp
Gravity	
Submersion	
Immersion	5,000 to 20,000 cp
Follower Plates	
Pressure	
Inductors	
Rams	100,000 to 6,000,000 cp

10. Explain the advantages of bulk unloading systems and give several examples of materials or applications for which they are appropriate.

Answers to Progress Check

1. b. Gravity feed
2. e. Pressure feed
3. c. Submersion feed
4. d. Immersion feed
5. a. Siphon feed
6. Follower plates are used in immersion feed systems with highly viscous materials (15,000 to 50,000 cp), such as greases in the lubrication industry.
7. The 25 percent pressure feed rule says that the feed supply pressure should not exceed 25 percent of the output fluid pressure of the piston pump being fed.
8. You might recommend an inductor systems to move viscous industrial fluids, from 20,000 to 100,000 cp, that flow slowly. Inductors can move food products (like mayonnaise) and greases in low temperature applications. You might recommend a ram system to move industrial fluids with viscosities from 100,000 to 6,000,000 cp. Ram systems can move one-part silicones and very heavy greases that need to be pumped in cold weather.

9.

Feed Methods and Viscosity Summary Chart	
Feed Method	Approximate Viscosity Range
Siphon	up to 5,000 cp
Gravity	up to 20,000 cp
Submersion	up to 5,000 cp
Immersion	5,000 to 20,000 cp
Follower Plates	15,000 to 50,000 cp
Pressure	5,000 to 150,000 cp
Inductors	20,000 to 100,000 cp
Rams	100,000 to 6,000,000 cp

10. Bulk unloading systems offer customers cost savings and efficiency. Due to lower cost of materials purchased in bulk and higher container disposal costs, the numbers of customers using these systems continually rises. Bulk unloading systems move greases, food products, sealants and adhesives, and inks. Automotive assembly plants, printing plants, and large commercial packaging plants all use the systems.

Delivery Issues

As you select equipment and accessories for your customer's application, you need to be aware of delivery, pressure, and flow issues that impact your customer's application. In a fluid handling system, there must be enough pressure to move the fluid through the system to feed an applicator. The pump you select must generate enough pressure to overcome any restrictions in the system and push the fluid at the proper velocity through the system.

Pressure in a system is a function of your customer's application—it is a function of the fluid's viscosity, the line size, and the distance the fluid will travel. In this section we will review five categories of applications. Each category lists delivery issues common to that category and includes an example of a customer application. After completing this section, you will be able to:

- Identify the delivery, pressure, and flow issues to be aware of in spray applications.
- Identify the delivery, pressure, and flow issues to be aware of in extrusion applications.
- Identify the delivery, pressure, and flow issues to be aware of in transfer applications.
- Identify the delivery, pressure, and flow issues to be aware of in dispense applications.
- Identify the delivery, pressure, and flow issues to be aware of in paint circulation applications.

Spray Applications

In spray applications, uniform system pressure with minimal fluctuations is critical to providing your customer with consistent finish quality.

An example of a typical spray application is a custom cabinet shop that is spray finishing cabinets with a clearcoat using an HVLV gun. Fluid pressure is between 5-10 psi (.3 and .7 bar) and the fluid flow rate is 6-8 ounces (.16-.22 kg) per minute.

Another example of a spray application is a manufacturer of microwave ovens that is spray finishing the exterior surface of the ovens with an enamel finish using electrostatic spray. Pressure is regulated down to 20-25 psi (1.4-1.7 bar) and the flow rate is 30 ounces (.84 kg) per minute.

Extrusion Applications

In extrusion applications, uniform pressure for uniform flow is required to provide a consistent bead size. It is important to be aware of the total pressure loss for the entire system, including all components of the system between the pump and the application tool. Also, consider the greater pressure due to the heavier viscosity material.

An example of a typical extrusion application is a customer using an adhesive to bond the aluminum parts of a satellite dish together. The customer is extruding a 3/16 inch (.45 cm) bead at 20 feet (6.09 meter) per minute. The adhesive is 120,000 cp and pressure loss in the system is 2,800 psi (193 bar).

Transfer Applications

In transfer applications, you will need to consider fluid viscosity, line size, and line length. Your customer's flow rate expectations should help you determine an appropriate line size to minimize restrictions and pressure loss. Since dispense pressure may not be important, there may be a need for a higher volume, lower pressure pump. In properly designed transfer applications, viscosity and line losses are often low, therefore pressure is usually not an issue. Line size can still be critical.

An example of a typical transfer application is a customer moving five different chemicals from bulk supply into a batch for mixing into a solution that will be applied to mylar tape to make it magnetic. Fluid flow rate is 3 gallons (11.4 liters) per minute on one pump and 0.5 to 1 gallon (1.9 to 3.8 liters) per minute on the other four pumps.

Dispense Applications

In addition to pressure loss due to line restrictions, in dispense applications you need to be aware of pressure loss due to dispense valves, nozzles, and metering. It is important that you match the fluid flow rate to the customer's production expectations.

An example of a typical dispense application is a heavy equipment manufacturer dispensing 90-weight gear oil into a gear box. The flow rate is set at 2 gallons (7.6 liters) per minute to meet the customer's production goals of filling the 20-gallon (75.7 liter) gearbox in ten minutes.

Paint Circulation Applications

In paint circulation applications, you need to be aware of the cumulative pressure loss effect of multiple drops. Make sure you add all dispense points, as well as circulation flow requirements to calculate pressure loss. Be aware of regulations on materials for piping; some areas of the country require a particular type of pipe due to corrosion control or safety guidelines.

An example of a typical paint circulation application is a customer air spraying clearcoat on rivets for the aircraft industry. The system has four gun drops. Fluid flow rate is 1 pint (.11 liter) per minute, per gun. Fluid pressure is 175 psi (12 bar) and air pressure is 65-70 psi (4.5-4.8 bar).

Pipe, Tubing, Fittings, and Hose

Pipe, tubing, fittings, and hose are all critical elements in any fluid handling system. Any one of them may impact the movement of fluids through the system.

After completing this section, you will be able to:

- List the critical components and construction materials for pipe, tubing, fittings, and hose.
- Describe the function of pipe, tubing, fittings, and hose in a fluid handling system.

Pipe

Pipe is typically used for air lines, and occasionally for fluid lines.

Schedule 40 galvanized pipe is most common and is frequently used for low pressure systems, such as compressed air and low pressure paint circulation. Also available is Schedule 80 heavy-duty pipe. Stainless steel pipe is becoming more common due to the increased use of water-borne fluids. Black pipe is often used for piping gas. Pipe is specified by its inside diameter and its weight.

While pipe is usually relatively low in cost, it is heavy compared to tubing, difficult to bend, difficult to flush, installation time is long, and vibration can loosen fittings.

Tubing

Tubing is an excellent choice for fluid lines, but can be used for all materials including oil, paint, water, and air. It works well in both low pressure and high pressure applications. Tubing offers less restriction than pipe due to smooth walls and typically fewer fittings. Tubing is specified by its outside diameter and can be made of three different types of materials.

Steel Tubing

Steel tubing is annealed, so it is easy to bend. Also, the inside is clean and free of rust and scale. Make sure you specify hydraulic grade steel tubing.

Stainless Steel Tubing

Use stainless steel tubing for water-borne or corrosive coatings. Stainless steel tubing is not annealed, so it is more difficult to work with than steel. However, it has a forty percent higher working pressure.

PVC Tubing

The third type of tubing is made of poly vinyl chloride (PVC), a low pressure plastic.

Fittings

For low pressure (air spray) applications, zinc plated brass fittings used with reusable couplings and quick disconnect fittings are a good solution. For high pressure applications, high pressure fittings are permanently coupled by the hose vendor to minimize injection hazard. When using high pressure tubing, welding the tubing and fitting is recommended. Fittings are specified by their diameter, thread type, and thread designation (see following chart).

Thread Types and Designations for Fittings	
Thread Types	Thread Designations
(F) female	NPSM (National Pipe Straight Mechanical)
(FxM) female and male	NPT (National Pipe Tapered)
(M) male	NH (National Garden Hose)
(MBE) male both ends	H (Dryseal Hose Coupling)
(FBE) female both ends	UNEF (Unified Extra Fine Thread)
	UNS (Unified Special Thread)

Figure 18: Fittings are specified by diameter, thread type and thread designation.

Hose

Hose is usually the lowest cost solution in a fluid handling system when flexibility is the primary need. Hose is appropriate where extreme heat and frequent flexing occurs, but make sure the hose you specify has the proper working pressure. Hose also serves the function of isolating equipment from vibration and allows ram and elevator movement.

You should be familiar with the four main components of a basic hose as illustrated in Figure 19.

The *cover material* should be abrasion resistant and compatible with fluids that may be spilled on the floor.

The *electrical ground* is accomplished either by dielectric material in the core or a metal braid. Water-borne materials in electrostatic systems use non-grounded hose.

The *braid material* may either be fabric or metal to add strength or to increase the working pressure performance. However, as working pressure increases, flexibility decreases.

The *tube material* the must be compatible with fluid being pumped and with the flushing fluid.

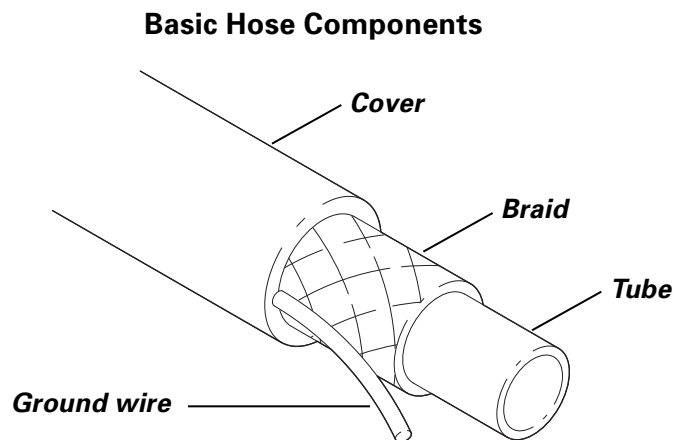

05638

Figure 19: Four main components of a basic hose.

Air Hose

Air hose is lined with a very flexible, rubber-lined material like Neoprene, Buna-N, or Buna-S. Air hose is constructed for very low pressures.

Fluid Hose

Fluid hose is typically nylon-lined, but Teflon may be used where moisture permeation is a concern; for example, with materials like isocyanate. Neoprene or Buna rubber materials are used for moving petroleum-based products like roof coatings or lubricants. Fluid hose construction ranges from low to high pressure.

Progress Check

Directions: After answering the following questions, compare your answers with those provided in the answer key following this progress check. If you respond to any items incorrectly, return to the text and review the appropriate topics.

For items 1 through 5, match the application category with delivery issues you should be aware of for that category.

Application Category

- a. Spray applications
- b. Extrusion applications
- c. Transfer applications
- d. Dispense applications
- e. Paint circulation applications

Delivery Issues

- ___ 1. You must be aware of the cumulative pressure loss effect of multiple drops. It is important to add all dispense points, as well as circulation flow requirement to calculate pressure loss.
- ___ 2. Uniform system pressure with minimal fluctuations is critical to providing your customer with consistent finish quality.
- ___ 3. In addition to pressure loss due to line restrictions, you need to be aware of pressure loss due to valves, nozzles, and metering. It is important to match the fluid flow rate to the customer's production expectations.
- ___ 4. You need to consider fluid velocity, line size, and line length. Use your customer's flow rate expectations to help you determine an appropriate line size, to minimize restrictions and pressure loss. There may be a need for a higher volume, lower pressure pump.
- ___ 5. Uniform pressure for uniform flow is required to provide a consistent bead size. Be aware of the total pressure loss for the entire system, including all components of the system between the pump and the application tool. Also, consider the greater pressure due to the heavier viscosity material.

6. In a fluid handling system, pipe is commonly used for air lines, and occasionally for fluid lines. What type of pipe is available?

7. Tubing is an excellent choice for fluid lines, but can be used for all materials including oil, paint, water, and air. What type of tubing is available?

8. Fittings are specified by what three characteristics?

For items 9 through 12, match the hose component with its description.

Hose Component

- a. Cover material
- b. Electrical ground
- c. Braid material
- d. Tube material

Description

- ___ 9. Accomplished either by dialectic material in the core or a metal braid.
- ___ 10. May be either fabric or metal to add strength or increase working pressure performance.
- ___ 11. Should be abrasion resistant and compatible with fluids that may be spilled on the floor.
- ___ 12. Must be compatible with the fluid being pumped and with the flushing fluid.

Answers to Progress Check

1. e. In paint circulation applications, be aware of the total pressure loss for the entire system, including all components of the system between the pump and the application tool. Also, consider the greater pressure due to the heavier viscosity material.
2. a. In spray applications, uniform system pressure with minimal fluctuations is critical to providing your customer with consistent finish quality.
3. d. In addition to pressure loss due to line restrictions, you need to be aware of pressure loss due to valves, nozzles, and metering in dispense applications. It is important to match the fluid flow rate to the customer's production expectations.
4. c. In transfer applications, you need to consider fluid velocity, line size, and line length. Use your customer's flow rate expectations to help you determine an appropriate line size, to minimize restrictions and pressure loss. There may be a need for a higher volume, lower pressure pump.
5. b. In extrusion applications, uniform pressure for uniform flow is required to provide a consistent bead size. Be aware of the total pressure loss for the entire system, including all components of the system between the pump and the application tool. Also, consider the greater pressure due to the heavier viscosity material.
6. Pipe is available in schedule 40 galvanized steel, schedule 80 heavy-duty steel, stainless steel, and black pipe.
7. Tubing is available in steel, stainless steel, and PVC.
8. Fittings are specified by diameter, thread type, and thread designation.
9. b. In a hose, electrical ground is accomplished by dielectric material in the core or a metal braid.
10. c. In a hose, the braid material may either be fabric or metal to add strength or increase working pressure.
11. a. In a hose, the cover material should be abrasion resistant and compatible with fluids that may be spilled on the floor.
12. d. In a hose, the tube material must be compatible with the fluid being pumped and with the flushing fluid.

Module Evaluation

The purpose of this Module Evaluation is to help the Graco Technical Communications department determine the usefulness and effectiveness of the module.

Instructions: Please complete the evaluation, tear it on the perforation, and return it Graco Technical Communications Department, P.O. Box 1441, Minneapolis, MN 55440-1441, USA.

1. *Based on the objectives, this module:*

- Significantly exceeded my expectations
- Exceeded my expectations
- Met my expectations
- Was below my expectations
- Was significantly below my expectations

2. *Why did you select the above rating?*

3. *How do you plan to use the module information in your job?*

4. *How do you think the module could be improved?*

I verify that I have successfully completed Module No. 321-037

Title Moving Fluids

Signature _____

Date _____



Graco

Technical Communications Dept.

P.O. Box 1441

Minneapolis, MN 55440-1441 U.S.A.

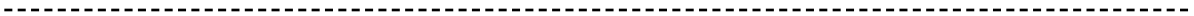

(fold here)

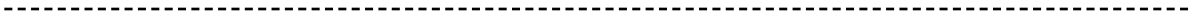

(fold here)

This module was developed by the Graco Technical Communications Department with assistance from the following individual:

Eric Hedman

Brian Johnson

Tom Ruff

Dennis VanKuelen

The Graco Concept and Theory Training program consists of the following topics:

Fluid Basics

Atomization

Electrostatic Spray Finishing

Safety

Airspray Technology

Fluid Types: Paints and Other Coatings

Fluid Types: Lubricants

Fluid Types: Sealants and Adhesives

Airless Atomization

Spraying Techniques

Transfer Efficiency

Fluid Movement

Fluid Controls

Pumps

Motors and Power Sources

Plural Component Paint Handling

Plural Component Sealant and Adhesive Handling

Paint Circulating Systems

Automatic Finishing

Lube Reels and Dispense Valves

Lube Metering Systems

Electronic Fluid Management Systems