

BRONZE OR ALUMINUM CLOSE COUPLED HELICAL ROTOR PUMP

MODEL
111
111B



OBERDORFER PUMPS
A Subsidiary of Thomas Industries Inc.

PIPE SIZE 3/4



FEATURES

- All Bronze or Corrosion Resistant Aluminum Construction
- Carbon Face Mechanical Seal
- Quiet Running Pump
- Can Handle Contaminated Liquids
- Buna Stator and Stainless Steel Rotor
- Easily Mounted in Field to Standard Briggs & Stratton or Tecumseh Engines

CHARACTERISTICS

The turning of the helical shaped rotor within the stationary stator creates a progressing cavity similar to a moving piston. Liquid is thus displaced generating a pumping action.

Unlike piston pumping, extremely high pressure cannot be created because the stator is made of Buna N and is flexible. Because of this flexibility contaminated liquids can be handled.

Close fit of the rotor within the stator permits lifting of liquid on the suction side as high as 20 ft. High starting torque motors are recommended in order to overcome the high starting friction of the stator. The pump is relatively quiet.

ROTATION

This helical rotor design demands a single rotation - clockwise when facing the pump drive shaft. Pump rotation and "in" and "out" ports are indicated on the dimension diagrams on reverse side.

MATERIALS OF CONSTRUCTION

These pump housings and mounting brackets are made from cast aluminum or bronze alloy. The rotor is made from stainless steel with a hard chrome plate for improved wear properties. The stator is made from molded Buna N. The mechanical seal is a carbon and ceramic rotary face type for positive sealing.

LIQUIDS

The corrosion resistant alloys used are compatible with common liquids including water, water solutions, oils and many commercial chemicals. Severe solvents are not compatible with the Buna and should not be pumped.

Pump No.	Engine	Material
111 UGY	3 H.P. Briggs & Stratton No. 80232 - Type 0400-01	Aluminum
111B UGY	3 H.P. Briggs & Stratton No. 80232 - Type 0400-01	Bronze
111	None (Pump Only)	Aluminum
111B	None (Pump Only)	Bronze

GASOLINE ENGINE MOUNTING

This pump is supplied close coupled to gasoline engine or as a pump alone complete with attaching parts and instructions for mounting. Any 2 or 4 cycle gasoline engine having a standard S.A.E. 4 bolt mounting flange and 5/8 inch shaft diameter with keyslot can be used. An engine rating of at least 2.2 horsepower at 3600 R.P.M. is necessary as only about one-half of rated power is available at the recommended pump speed of 2100 R.P.M. Larger horsepower engines (3 H.P. at 3600 R.P.M.) with 5/8 inch shaft diameter and suitable flange mounting provide extra power to compensate for power losses due to carbon deposits and gumming.

CAPACITY - WATER 60°F

AVG. ENGINE SPEED 2100 R.P.M.

Pressure P.S.I.	0	10	20	30	40	50	60	70	80	90	100
Flow G.P.M. (Water)	10	9 1/2	9	8 1/2	8	7 1/2	7	6	5	4 1/2	4

MODEL
111
111B

BRONZE OR ALUMINUM CLOSE COUPLED HELICAL ROTOR PUMP



PARTS LIST - GASOLINE ENGINE MOUNTING

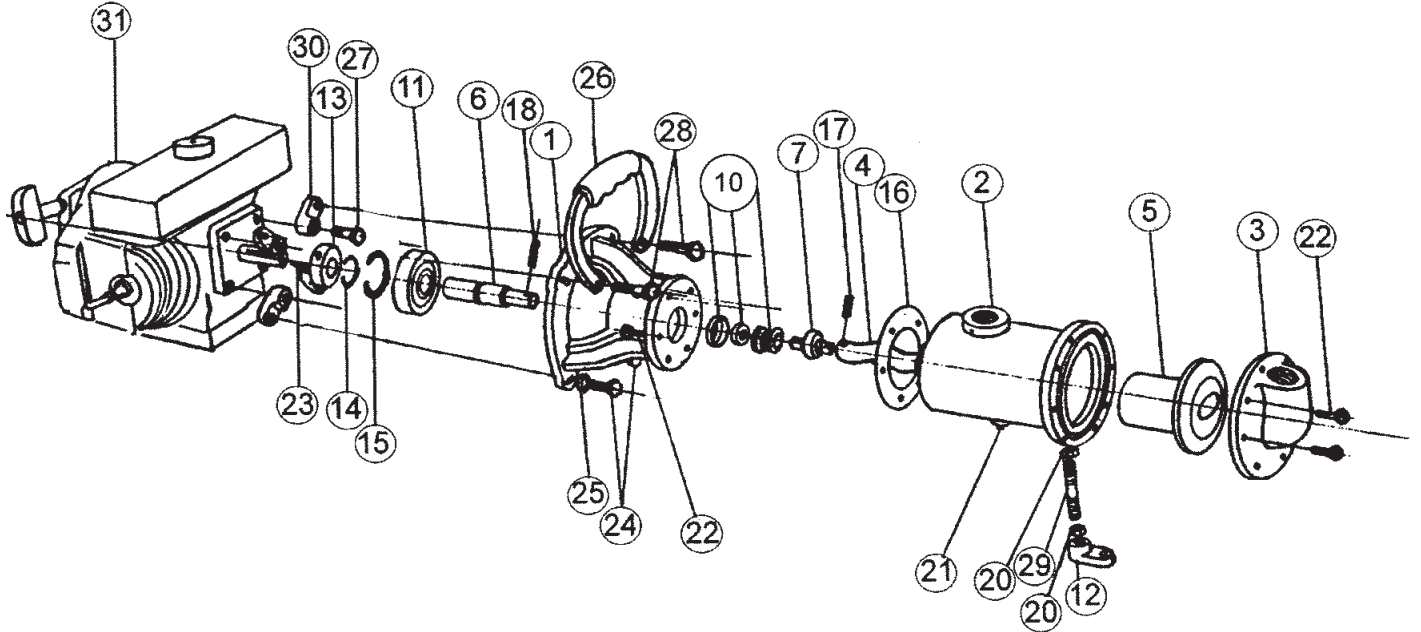

Pump No.	1 Adapter Bracket 1 Req'd	2 Body 1 Req'd	3 Cover 1 Req'd	4* Rotor 1 Req'd	5* Stator 1 Req'd	6 Drive Shaft 1 Req'd	7 Universal Joint 1 Req'd	10* Seal Assem. 1 Req'd	11 Ball Bearing 1 Req'd	12 Foot 1 Req'd	13 Collar 1 Req'd	14 Retaining Ring 1 Req'd	15 Ret. Ring 1 Req'd	16* Gasket 1 Req'd	17* Pin 1 Req'd
111 UGY	5871	5873	5872	5890	5891	5875	5874	32156	5884	5881	5886	5885	6053	5882	5888
111B UGY	7213	6897	6896	5890	5891	5875	5874	32156	5884	5881	5886	5885	6053	5882	5888

* Repair Kit No. 10737 include these parts and compression plate tool for seal removal

18*	19	20	21	22	23	24	25	26*	26**	27	28	29	30
Pin	Nut	Plug	Screw	Key	Screw	Washer	Handle	Screw	Screw	Screw	Stud	Lug	Engine
1 Req'd	1 Req'd	2 Req'd	14 Req'd	1 Req'd	2 Req'd	4 Req'd	1 Req'd	4 Req'd	4 Req'd	2 Req'd	1 Req'd	4 Req'd	1 Req'd
5889	5597	5908	5897	5912	5916	5915	5919	5923	5930	5595	5922	5921	7230
5889	5597	5395	5897	5912	5916	5915	7402	5923	5930	5595	5922	5921	7230

DIMENSIONS

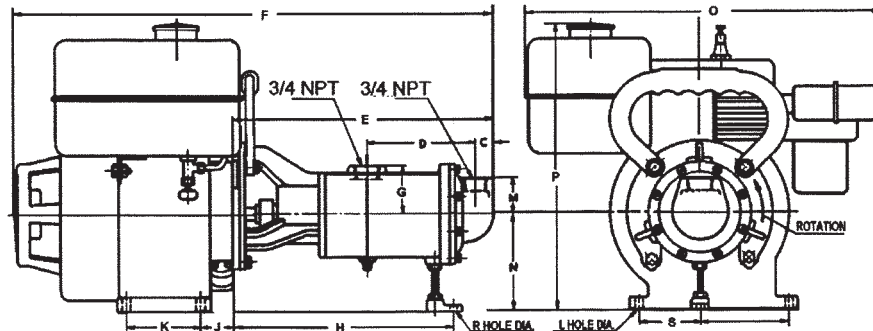

Pump No.	C	D	E	F	G	H	J	K	L	M	N	O	P	R	S	T
*111 UGY & 111B UGY	13/16	4 9/16	11 1/4	20 17/32	2 1/16	9 19/32	1 13/32	3 1/8	11/32	1 9/16	4 3/16	15 1/2	12 7/16	11/32	2 19/32	3 25/32

* With Briggs & Stratton Engine No. 80232 having 5/8 dia. keyed shaft.