

BRONZE OR ALUMINUM PEDESTAL HELICAL ROTOR PUMP

**MODEL
121
121B**



PIPE SIZE 3/4

CAPACITY - WATER 60°F
GALLONS PER MIN. - WATER & HORSEPOWER*

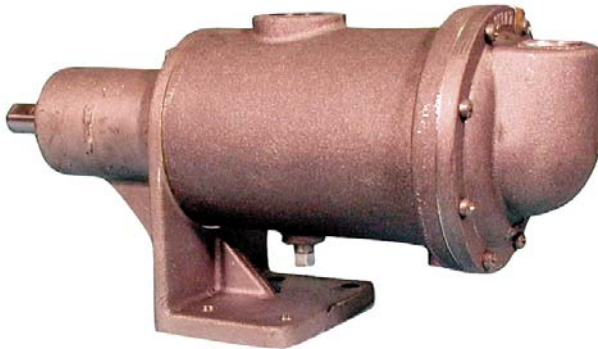

Pump No.	Material
121	Aluminum
121B	Bronze

Pump R.P.M.	Pressure P.S.I.											
	0		20		40		60		80		100	
	GPM	HP	GPM	HP	GPM	HP	GPM	HP	GPM	HP	GPM	HP
400	1.4	1/4	1.3	1/4	1.2	1/4	1.1	1/4	0.9	1/4	0.7	1/4
600	2.4	1/4	2.3	1/4	2.1	1/4	1.8	1/4	1.6	1/3	1.2	1/3
800	3.6	1/4	3.4	1/4	3	1/4	2.7	1/3	2.1	1/2	1.6	1/2
1000	4.6	1/4	4.2	1/4	3.7	1/3	3.2	1/2	2.7	1/2	2	1/2
1200	5.6	1/4	5.1	1/4	4.6	1/3	3.9	1/2	3.3	1/2	2.6	1/2
1400	6.7	1/4	5.9	1/3	5.1	1/3	4.4	1/2	3.7	1/2	3.1	3/4
1600	7.8	1/4	6.8	1/3	5.9	1/2	5	1/2	4.2	3/4	3.5	3/4
1725	8.5	1/4	7.5	1/3	6.5	1/2	5.5	1/2	4.5	3/4	3.7	3/4

Viscosity Saybolt Seconds Universal S.S.U.	Maximum Recommended Pump R.P.M.	Liquid Example
50	1725	Water
500	1400	Corn Syrup
1000	1200	SAE 30 Oil
5000	800	Mineral Oil
10000	600	SAE 50 Oil
50000	400	Molasses

FEATURES

- All Bronze or Corrosion Resistant Aluminum Construction
- Heavy Duty Ball Bearings
- Designed for Pulley Drive Applications
- Quiet Running
- Can Handle Contaminated Liquids
- Carbon Face Mechanical Seal
- Buna Stator and Stainless Steel Rotor

SPEED AND DRIVE

Viscous or thick liquids must be pumped at slower speeds as indicated in the above table. Speed reduction from standard electric motor speed can be obtained by pulleys in the direct ratio of speed reduction desired - large pulley on pump, small pulley on motor.

Heavy liquids can be pumped at higher speeds but require more horsepower in direct amount to their specific gravity - for example, a liquid with a specific gravity of 1.3 would require 1.3 times the original horsepower.

CHARACTERISTICS

The turning of the helical shaped rotor within the stationary stator creates a progressing cavity similar to a moving piston. Liquid is thus displaced generating a pumping action. Unlike piston pumping, extremely high pressure cannot be created because the stator is made of Buna N and is flexible. Because of this flexibility contaminated liquids can be handled.

Close fit of the rotor within the stator permits lifting of liquid on the suction side as high as 20 ft. High starting torque motors are recommended in order to overcome the high starting friction of the stator. The pump is relatively quiet.

ROTATION

This helical rotor design demands a single rotation - clockwise when facing the pump drive shaft. Pump rotation and "in" and "out" ports are indicated on the dimension diagrams on reverse side.

MATERIALS OF CONSTRUCTION

These pump housings and mounting brackets are made from cast aluminum or bronze alloy. The rotor is made from stainless steel with a hard chrome plate for improved wear properties. The stator is made from molded Buna N. The mechanical seal is a carbon and ceramic rotary face for positive sealing.

LIQUIDS

The corrosion resistant alloys used are compatible with common liquids including water, water solutions, oils and many commercial chemicals. Severe solvents are not compatible with the Buna and should not be pumped. Viscous liquids can be pumped, but at slower speeds. Samples of liquids, viscosity and recommended pump shaft R.P.M. are given on this page. Contaminated liquids can be pumped because of the flexible Buna stator.

MODEL
121
121B

BRONZE OR ALUMINUM HELICAL ROTOR PUMP



PARTS LIST

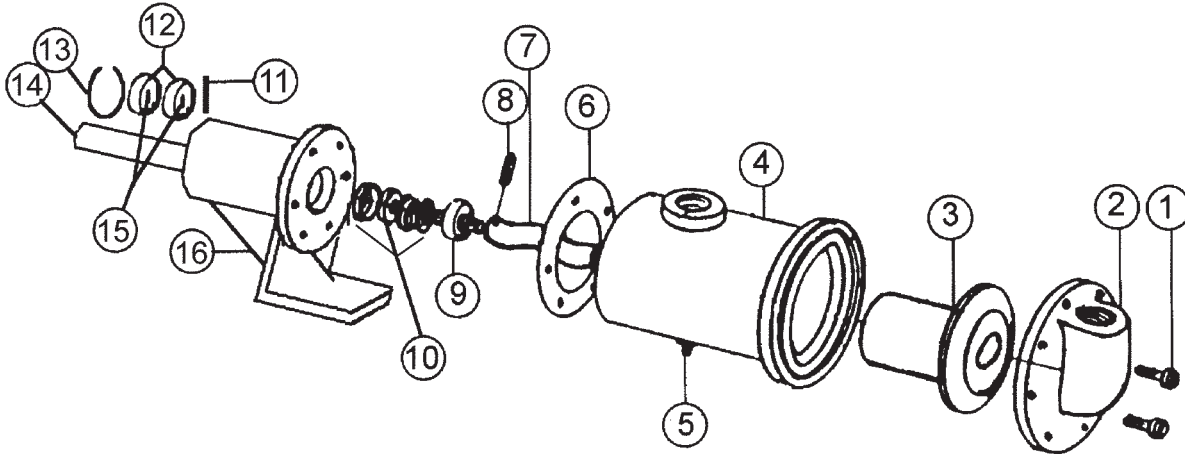

Pump No.	1 Screw	2 Cover	3* Stator	4 Body	5 Plug	6* Gasket	7* Rotor	8* Pin	9 Universal Joint
	14 Reqd	1 Reqd	1 Reqd	1 Reqd	1 Reqd	1 Reqd	1 Reqd	1 Reqd	1 Reqd
121	5897	5872	5891	5873	5908	5882	5890	5888	5874
121B	5897	6896	5891	6897	5395	5882	5890	5888	5874

10* Seal Assembly	11 Pin	12 Ball Bearing	13 Snap Ring	14 Shaft	15 Snap Ring	16 Pedestal
1 Reqd	1 Reqd	2 Reqd	1 Reqd	1 Reqd	1 Reqd	1 Reqd
32156	5889	5928	5925	5927	5926	5924
32156	5889	5928	5925	5927	5926	6895

* Repair Kit #10737. Kit includes these parts. (and others for 101/101B) as well as compression plate tool for seal removal.

DIMENSIONS

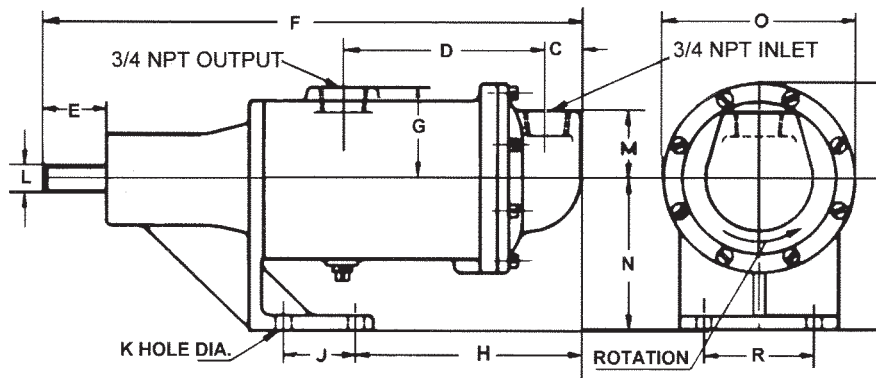

Pump No.	C	D	E	F	G	H	J	K	L	M	N	O	P	R
121 & 121B	13/16	4 9/16	1 3/8	12 1/8	2 1/16	5 1/8	1 5/8	11/32	5/8	1 9/16	3 1/2	4 3/8	5 11/16	2 1/2