

BRONZE OR ALUMINUM CLOSE COUPLED HELICAL ROTOR PUMP

MODEL
101
101B



OBERDORFER PUMPS

A Subsidiary of Thomas Industries Inc.

PIPE SIZE 3/4



FEATURES

- All Bronze or Corrosion Resistant Aluminum Construction
- Easily Mounted in Field to your own 56 Frame Motor & 56C for explosion-proof motors
- Carbon Face Mechanical Seal
- Quiet Running
- Can Handle Contaminated Liquids
- Buna Stator and Stainless Steel Rotor

Pump No.	Motor *	Enclosure	Frame	Body Construction
101	Pump Only		56	Aluminum
101-J25	1/2 HP, 1 Phase, 115/230 V	ODP		
101-J54	1/2 HP, 3 Phase, 208-220/440 V	ODP		
101-M07	3/4 HP, 1 Phase, 115/230 V	ODP		
101-M51	3/4 HP, 3 Phase, 220/440 V	ODP		
101B	Pump Only		56	Bronze
101B-J08	1/2 HP, 1 Phase, 115/230 V	TE		
101B-J25	1/2 HP, 1 Phase, 115/230 V	ODP		
101B-J54	1/2 HP, 3 Phase, 208-220/440 V	ODP		
101B-M07	3/4 HP, 1 Phase, 115/230 V	ODP		
101B-M51	3/4 HP, 3 Phase, 220/440 V	ODP		
101G	Pump Only		56C	Aluminum
101G-J97	1/2 HP, 3 Phase, 240/480 V	TE		
101G-M97	3/4 HP, 3 Phase, 230/460 V	TE		
101BG	Pump Only		56C	Bronze
101BG-J97	1/2 HP, 3 Phase, 240/480 V	TE		
101BG-M97	3/4 HP, 3 Phase, 230/460 V	TE		

* Other motors available

ELECTRIC MOTOR MOUNTING

This pump is supplied close coupled to electric motor or as a pump alone complete with attaching parts and instructions for mounting. Any 56 frame electric motor (or 56C frame) with 5/8 inch shaft diameter, 1725 R.P.M. and of horsepower rating as listed above can be used. The motor can be rigid or resilient mounted, sleeve or ball bearings, 50°C rise, capacitor start, counter-clockwise, rotation from shaft end. (For Gas Engine version, see models 111-UGY/111B-UGY)

CAPACITY - WATER 60° F 1725RPM

Pressure P.S.I.	0	10	20	30	40	50	60	70	80	90	100
Flow G.P.M. (Water)	8 1/2	8	7 1/2	7	6 1/2	6	5 1/2	5	4 1/4	3 3/4	3 1/4
Electric Motor H.P.	1/2	1/2	1/2	1/2	1/2	1/2	1/2	1/2	3/4	3/4	3/4

(FOR PERFORMANCE AT REDUCED MOTOR SPEEDS, SEE MODEL 121/121B)

CHARACTERISTICS

The turning of the helical shaped rotor within the stationary stator creates a progressing cavity similar to a moving piston. Liquid is thus displaced generating a pumping action. Unlike piston pumping, extremely high pressure cannot be created because the stator is made of Buna N and is flexible. Because of this flexibility contaminated liquids can be handled.

Close fit of the rotor within the stator permits lifting of liquid on the suction side as high as 20 ft. High starting torque motors are recommended in order to overcome the high starting friction of the stator. The pump is relatively quiet.

ROTATION

This helical rotor design demands a single rotation - clockwise when facing the pump drive shaft. Pump rotation and "in" and "out" ports are indicated on the dimension diagrams on reverse side.

MATERIALS OF CONSTRUCTION

These pump housings and mounting brackets are made from cast aluminum or bronze alloy. The rotor is made from stainless steel with a hard chrome plate for improved wear properties. The stator is made from molded Buna N. The mechanical seal is a carbon and ceramic mechanical rotary face type for positive sealing.

LIQUIDS

The corrosion resistant alloys used are compatible with common liquids including water, water solutions, oils and many commercial chemicals. Severe solvents are not compatible with the Buna and should not be pumped.

MODEL
101
101B

BRONZE OR ALUMINUM HELICAL ROTOR PUMP



OBERDORFER PUMPS
A Subsidiary of Thomas Industries Inc.

PARTS LIST

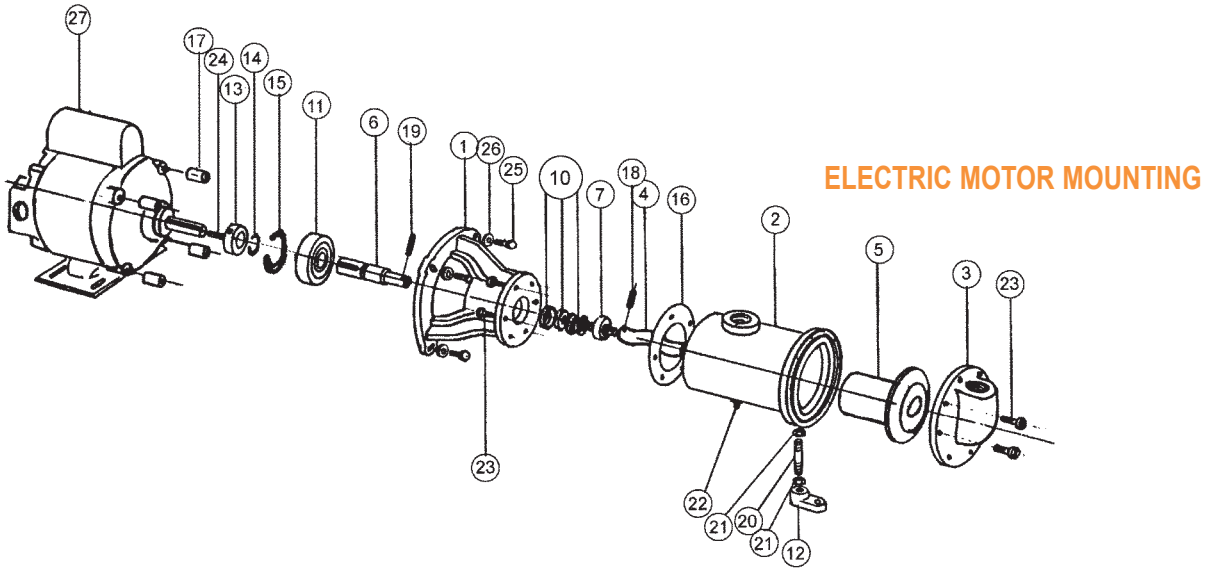

Pump No.	1	2	3	4*	5*	6	7	10*	11	12	13	14	16*	17	18*	19*
	Adapter Bracket	Body	Cover	Rotor	Stator	Drive Shaft	Universal Joint	Seal Assem.	Ball Bearing	Foot	Collar	Retaining Ring	Gasket	Nut	Pin	Pin
	1 Reqd	1 Reqd	1 Reqd	1 Reqd	1 Reqd	1 Reqd	1 Reqd	1 Reqd	1 Reqd	1 Reqd	1 Reqd	1 Reqd	1 Reqd	1 Reqd	1 Reqd	1 Reqd
101 J25	5871	5873	5872	5890	5891	5875	5874	32156	5884	5881	5886	5885	5882	6350	5888	5889
101 M07	5871	5873	5872	5890	5891	5875	5874	32156	5884	5881	5886	5885	5882	6350	5888	5889
101B J25	7213	6897	6896	5890	5891	5875	5874	32156	5884	5881	5886	5885	5882	6350	5888	5889
101B M07	7213	6897	6896	5890	5891	5875	5874	32156	5884	5881	5886	5885	5882	6350	5888	5889

* Repair Kit No. 10737 include these parts and compression plate tool for seal removal

20	21	22	23	24	25	26	27
Body	Nut	Plug	Screw	Key	Stud	Acorn Nut	Motor
1 Reqd	2 Reqd	1 Reqd	14 Reqd	1 Reqd	4 Reqd	4 Reqd	4 Reqd
5873	5597	5908	5897	5912	6349	6351	5918
5873	5597	5908	5897	5912	6349	6351	5913
6897	5597	5908	5897	5912	6349	6351	5918
6897	5597	5908	5897	5912	6349	6351	5913

DIMENSIONS

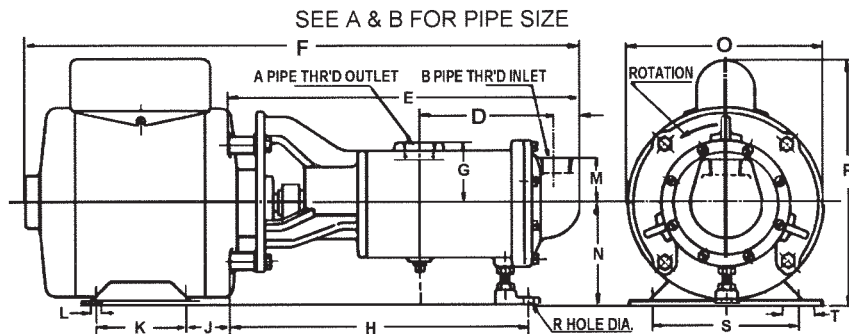

Pump No.	C	D	E	F	G	H	J	K	L	M	N	O	P	R	S	T
101 J25	13/16	4 9/16	11 7/8	18 1/2	2 1/16	10 7/32	1 1/16	3	11/32	1 9/16	3 1/2	6 1/2	8 9/16	11/32	4 7/8	1 3/16
101B J25																