

# Performance Specifications

RATIO:	1:1
MAX. G.P.M. (LPM):	170 (644)
DISPLACEMENT GALLONS (Liters) PER CYCLE:	1.4 (5.3)
AIR INLET:	3/4" NPTF (f)
AIR EXHAUST:	1-1/2" X 11 NPTF (f)
FLUID INLET:	2" NPTF (f), BSP (f) or Flange
FLUID OUTLET:	2" NPTF (f), BSP (f) or Flange
MAX. OP. PRESSURE PSI (bar):	120 (8.3)
PASS SOLIDS MAX. DIA. IN. (mm):	1/4 (6.4)
WEIGHT LBS. (Kgs.):	64 (29) Aluminum 133 (60) Cast Iron 154 (70) Stainless Steel (Note: add 34 lbs. (15 kg) for Stainless or Cast Iron Motor)
MAX. DRY SUCTION LIFT:	19 ft. (Rubber fitted)

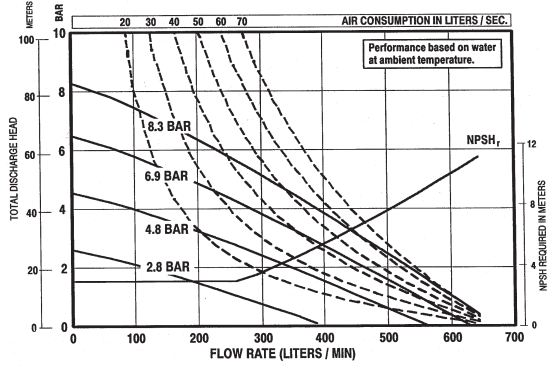
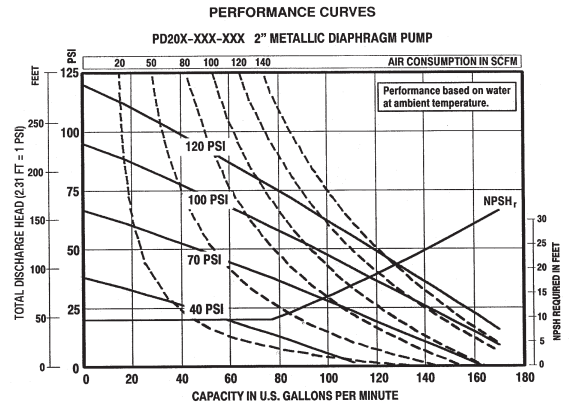

# Dimensional Data

Air Motor Muffler **Now** Included! (Muffler Dimensions Not Shown)

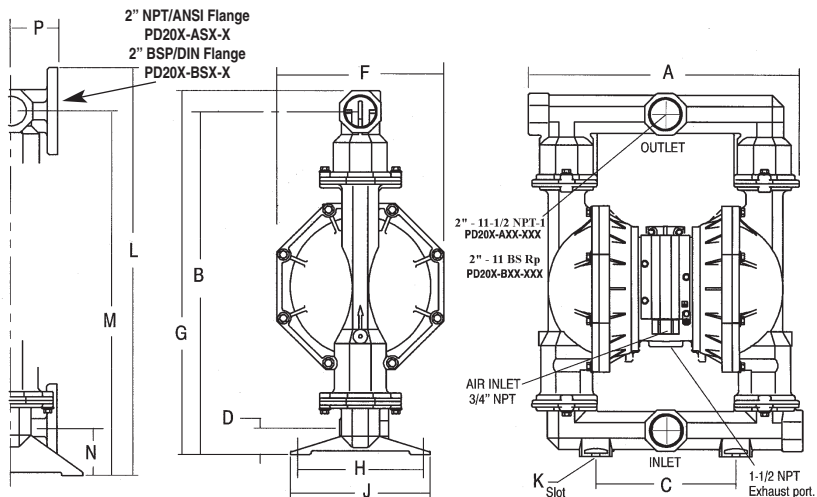

**DIMENSIONS**

A	19-3/4" (502 mm)	F	12" (305 mm)	L	28-5/8" (727 mm)
B	24-3/4" (629 mm)	G	26-1/4" (667 mm)	M	25-5/8" (651 mm)
C	10-1/16" (256 mm)	H	9-1/16" (230 mm)	N	3-3/8" (86 mm)
D	1-7/8" (48 mm)	J	10-1/16" (256 mm)	P	2-1/4" (82.5 mm)
		K	9/16" (14 mm)		

# Accessories

## Recommended Filter-Regulator (See Page 38)

Filter / Regulator: P29241-610

For complete airline connection kit, see page 34, item "B". Pulsation Dampener, see page 25.



P29241-610

For Diaphragm Pump Accessories see pages 34-36.

For recommended key models, refer to the ARO diaphragm pump price book (Form 2240-2). If the specific model you seek is not in the price book, consult the factory for further selection assistance.



Screened Inlet Kits Available. See Page 34.

# Ordering

Best Selling Models | PD20A-AAP-GGG, PD20A-ACP-AAA, PD20A-ASP-KTT, PD20A-AAP-KTT, PD20A-ASP-AAA, PD20C-ASS-KTT

Base Model	Center Section	Port	Wetted End	Hardware	Seat Material	Ball Check/ Diaphragm
<b>P D 2 0</b>	<b>X</b>	<b>X</b>	<b>X</b>	<b>X</b>	<b>X</b>	<b>X</b>
2" Pump	A Aluminum C Cast Iron S 316 St. Steel	A NPT B BSP	A Aluminum C Cast Iron S 316 St. Steel	P Plated Steel S Stainless Steel	AA Santoprene/Santoprene GG Nitrile/Nitrile TT Teflon®/Teflon	A Santoprene G Nitrile H 440 SS Hardened K Kynar (PVDF) S 316 St. Steel

**NOTE:** Side Port option not available on Stainless Steel Models.

**IRARO** | One Aro Center I.P.O. Box 151 | Bryan, Ohio 43506-0151  
(419) 636-4242 | (419) 633-1674 Fax | www.arozone.com

The most advanced process pump on the market

