

Pump Performance

- Air Inlet Pressure Range 30 - 120 PSI (2 - 8.3 bar)
- Fluid Pressure Range 1200 - 4800 PSI (81.6 - 326.5 bar)
- Max. Rec'd Cycles Per Minute . 60
- Displacement Per Cycle 14.5 in³ (237.6 cm³)
- Cycles Per Gallon (Liter) 16 (4.2)
- Flow @ 60 Cycles / Minute 3.7 GPM (13.9 lpm)
- Noise Level @ 60 Psi 89.8 db(A)

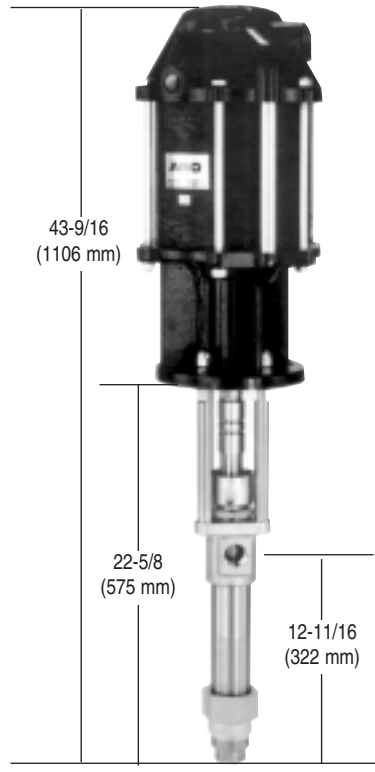

650883-X4X-B

Pump Specifications

- Lower Pump Material 316 Stainless Steel
- Plunger Material See "Plunger Options" Below
- Cylinder Material See "Plunger Options" Below
- Air Motor 66523-B
- Motor Repair Kit 66614
- Motor Diameter 8"
- Stroke 6"
- Air Inlet 3/4" NPT(F)
- Exhaust Port 1-1/4" NPT(F)
- Two-Ball Pump Model 66300-X4X
- Lower Pump Repair Kit 637305-X43
- Material Inlet 1" NPT(F) 2" NPT(M)
- Material Outlet 1" NPT(F)
- Weight 68.1 lbs. (30.9 kgs.)

Ordering

- 6 5 0 8 8 3 - X 4 X - B**
- Packings** ————— **Plungers**
- 3** : Teflon
 - C** : UHMW-PE
 - G** : UHMW-PE/Leather Staggered
 - P** : UHMW-PE/Teflon Staggered (Upper), UHMW-PE (Lower)
 - R** : Teflon/UHMW-PE Staggered (Upper), Teflon (Lower)
 - D** : 17-4 S. S. Hard Chrome Plated
 - G** : 17-4 S.S. "Ultra" Coated

Accessories

- Air F/R/L:** 28353
- Airline Oil:** 62274
- Air Motor Muffler:** 92460
- Wet Sol:** 66333-B
- Floor/Follower Adapter:** 67136
- Rams:** Page 14
- Floor Mounts:** 65138

