

DV 720 Series Timer Drains



Features:

Compact Size

Nema 4X

Power On Light

Valve On Light

Dual Timing Adjustments

Manual Override

CRUS rated

Strainer/Shut-off Valve/Option

Made in U.S.A.

Valve Connection: 1/4" NPT
Max. Pressure: 250 psi. to 300psi.
Seat Material: Viton
Voltage: 120 volt
Enclosure: Nema 4
Adjustable Timing: .5 - 10 sec. "on"& .5-45 min. "off"
Power Connection: 6' Grounded Cord

Its compact size and light weight allow the timer to be installed directly on drain points on filters, separators, dryers, drop legs, and air compressor receivers. The sealed high impact timer enclosure provides weather tight protection.

A bright yellow light indicates that power is applied to the timer, an additional yellow light indicates when power is being applied to the valve.

The timer/drain is useful over a wide range of applications because its dual timer allows the user to accurately set the correct drain cycle. A manual test button provides confirmation of the valve operation. The strainer/shut-off valve prevents the valve from being clogged up with scale.

AIR SYSTEM PRODUCTS, INC.

51 Beach Ave. Lancaster, NY. 14086

Tel: (716) 683-0435 Fax: (716) 683-7128 Web: www.airsyspro.com

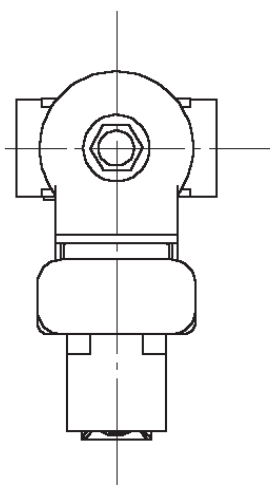

DIMENSIONAL DATA

MODEL #	"A"	"B"	"C"	"D"
DV720-66	.25	1.4	3.8	3.4
DV720-22	.25	2.2	4.9	3.9
DV720-23	.38	2.2	4.9	3.9
DV720-24	.50	2.2	4.9	3.9

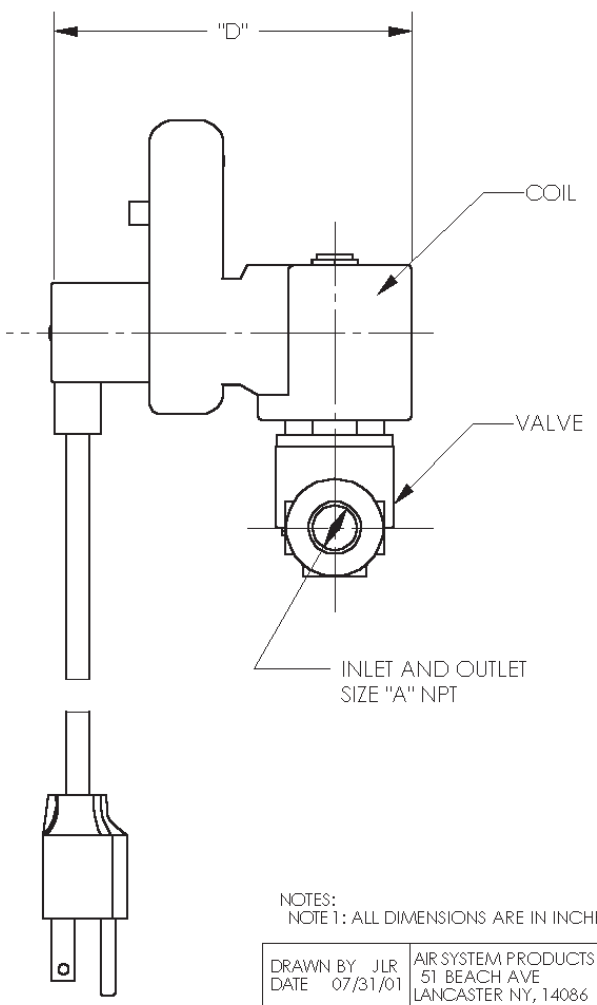
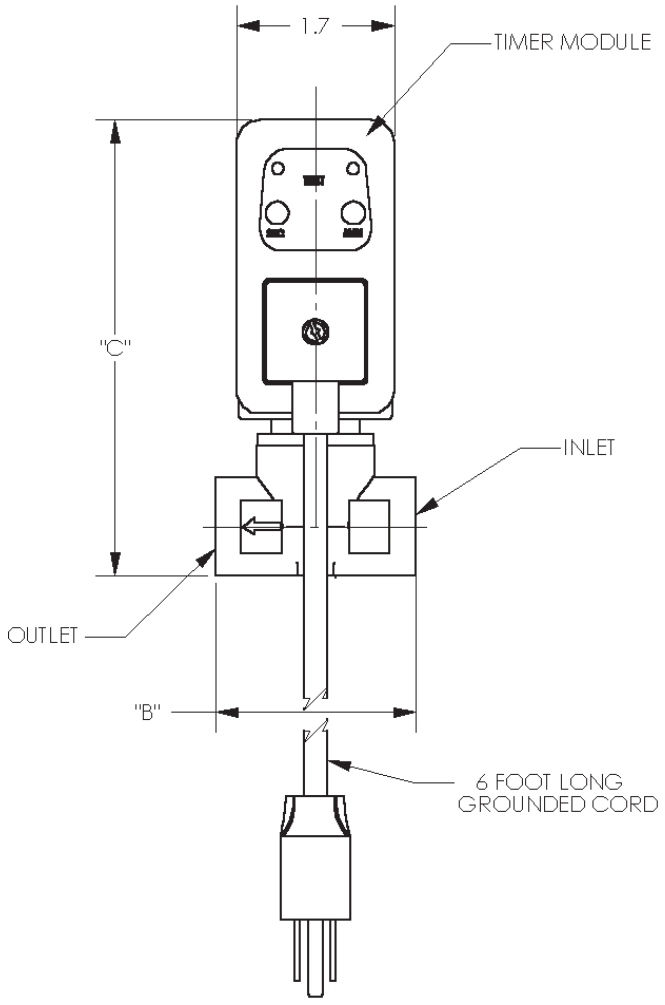
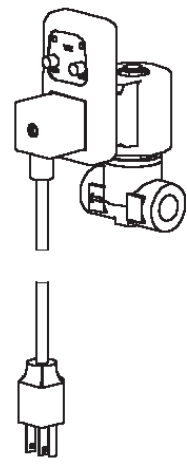

NOTES:
NOTE 1: ALL DIMENSIONS ARE IN INCHES.

DRAWN BY JLR DATE 07/31/01	AIR SYSTEM PRODUCTS INC 51 BEACH AVE LANCASTER NY, 14086
TITLE DV720 SERIES OUTLINE ELEVATION	
DRAWING # DV720-OUTLINE REV	