



***Achieving Assembly Excellence***

[www.AIMCO-GLOBAL.com](http://www.AIMCO-GLOBAL.com)

# TABLE OF CONTENTS

## ACRADYNE®

IEC CONTROLLERS	10-12
TOOLWARE	13
1000 SERIES NUTRUNNERS	14-15
1000, 2000 & 5000 SERIES PISTOL GRIP NUTRUNNERS	16-17
2000, 3000 & 5000 SERIES ANGLE/INLINE NUTRUNNERS	18-21
5000 SERIES FIXTURED NUTRUNNERS	22
TUBENUT NUTRUNNERS	23
HOLD & DRIVE NUTRUNNERS	24
MID-EXIT CABLE NUTRUNNERS	25
RIV-NUT NUTRUNNERS	26
HT SERIES NUTRUNNERS	27-29
TOOL/SPINDLE SELECTION GUIDE	30-31
ACCESSORIES	32-34
ACRADYNE® SYSTEMS	35

## URYU

FIXTURED F-SERIES NUTRUNNERS	36-39
CONTROLLERS	40-42
CONTROLLED PULSE TOOLS	43-47
CONTROLLER ACCESSORIES	48-49

## AUDITOR™

TORQUE MEASUREMENT: OVERVIEW	50-52
TORQUE CUBE™	53
DESKTOP TESTERS	54
TORQUE DATA ANALYZERS	55-56
TRANSDUCERS	57-58
RUNDOWN FIXTURES	59
WIRELESS TRANSDUCER	59
DIGITAL WRENCH SERIES	60
ELECTRONIC TORQUE WRENCHES	61
TORQUE MEASUREMENT ACCESSORIES	61
PRESET TORQUE WRENCHES	62
HIGH-CAPACITY TEST STANDS	63-64
UFT SERIES JOINT SIMULATORS	65
TORQUE CART / TOOLSTRAC	66-67
APPENDICES	68-71

## POWER TOOLS

AIMCO PULSE TOOLS: OVERVIEW	72-73
UAT SERIES	74-75
OMEGA PULSE TOOLS: ULT SERIES	76-77
OMEGA PULSE TOOLS: UL SERIES	78
ACRA-PULSE® SERIES	79-81
UDPB PULSE SERIES CORDLESS TOOLS	82
NUTRUNNERS: OVERVIEW	83
NUTRUNNERS	84-85
SCREWDRIVERS: OVERVIEW	86
SCREWDRIVERS	87-89
SIGNATURE SERIES CORDLESS TOOLS	90-92
ELECTRIC SCREWDRIVERS	94-96
IMPACT TOOLS	97
GRINDERS AND SANDERS	98
DRILLS & PERCUSSION TOOLS	99

## ASSEMBLY SYSTEMS

SCREW PRESENTERS: OVERVIEW	100
A-50 SCREW PRESENTERS	101
SCREW FEEDERS	102

## TOOL SUPPORT SYSTEMS

BALANCERS	103-104
RETRACTORS	104
ERGO-ARM® TOOL SUPPORT SYSTEMS	105
ERGO-ARM® ACCESSORIES / LINEAR ARM	106
CUSTOM REACTION DEVICES	106
CARBON TORQUE ARMS	107
WORKSTATION COMPONENTS AND ASSEMBLIES	108-109
AIR PREPARATION UNITS	110
AIR LINE	111-112

## FASTENER TOOLS

STANDARD FASTENER TOOLS	113-115
ERGO-DRIVE® SERIES	116-117
CUSTOM / SPECIAL PARTS	118-121
CONVERSION CHARTS	122

## AIMCO

For over 40 years AIMCO has been working with manufacturers around the world, we are the complete global source for all assembly needs involving threaded fastening. AIMCO can effectively and swiftly meet your needs whether you're in Thailand fastening a 3mm nut at 3Nm, or in Tennessee, USA torquing the last lug nut. AIMCO provides the tools and solutions, on a global scale, that guarantee the success of your project. AIMCO is the single source for your assembly needs regardless of your global location. It is with great pride that AIMCO can say the products that we manufacture are **MADE IN THE USA.**



## PRODUCTIVITY

*The speed and efficiency of the assembly process*

Every manufacturer wants to produce finished goods in the most cost-effective manner possible. Whether the customer is a large automotive manufacturer, building several hundred vehicles daily, or an electronics company producing individual, custom made components, AIMCO provides products and services that allow each company to work at their ideal pace in order to keep its processes running efficiently.



## ERGONOMICS

*The relationship between assembler and the assembly process*

Employees are the most important assets of any company. Protecting these individuals from job related health issues is critical. To help its customers face the challenges surrounding ergonomics, AIMCO focuses on providing products that combine a lack of torque reaction, low vibration, light weight, as well as quiet and simple operation. These features allow assemblers to do their job in the safest possible manner and help manufacturers avoid the often hidden costs of workplace injuries.



## RELIABILITY

*The total cost of tool maintenance and repair*

To keep production lines running, tools must perform reliably. AIMCO helps manufacturers face the challenges of maintenance, repair and lost labor time by offering products with superior workmanship and durability. By combining high quality products with a detailed and flexible service-training program, AIMCO ensures its tools will meet the customer's expectations of reliability.



## QUALITY

*The ability of the tool to adhere to process requirements*

The most important challenge faced by many companies is to meet the customer's demands for quality. AIMCO provides assembly tools that have been tested and proven to be able to meet the most stringent engineering specifications. AIMCO backs those tools up with its innovative Auditor™ torque measurement products. This allows manufacturers to focus on their most important goal—creating a quality product.





PERQ<sup>®</sup> is the industry-standard formula that matches the needs of manufacturers with the assembly tools they use in their processes.

AIMCO and its distributors evaluate each manufacturer based on the PERQ<sup>®</sup> formula to determine that company's unique blend of the PERQ<sup>®</sup> elements – productivity, ergonomics, reliability and quality – we then provide tooling options that will enhance that mix. The end result is a manufacturing process that runs efficiently, produces high quality products and does so at the lowest possible cost.

Combining PERQ<sup>®</sup> with AIMCO's vast experience and unequalled service will enable any manufacturer to succeed in the global marketplace.

Each of the PERQ<sup>®</sup> elements acts as a gear – each interacts with the others to affect the overall profitability of the manufacturing process. AIMCO looks at each step in the manufacturing process to determine the best type of tool, or equipment, for that application. Only AIMCO, with its extensive product lineup, can offer the manufacturer the ideal tool for the job, whether it be continuous drive or pulse tool, electric, pneumatic or battery powered.

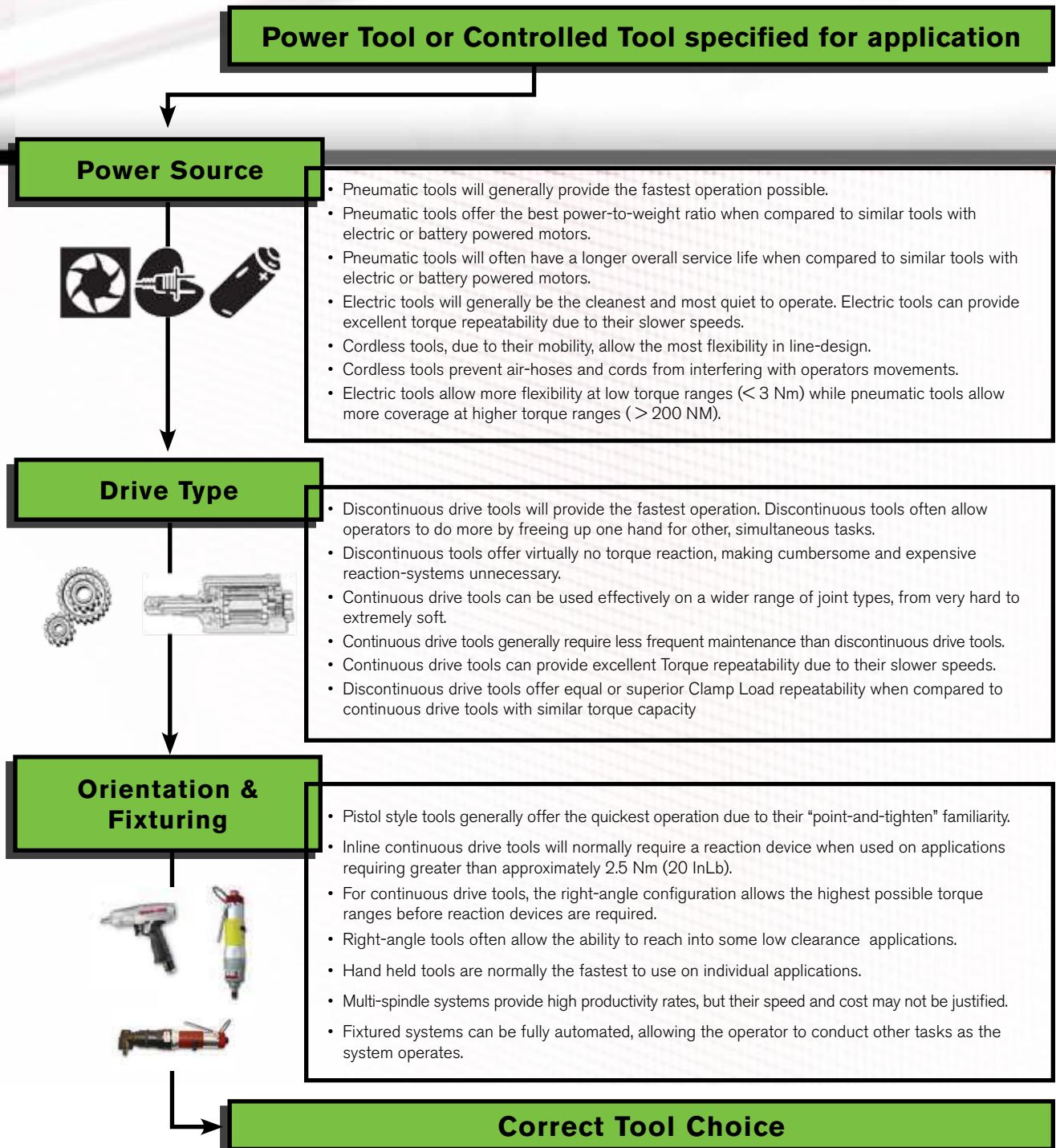



## OVERVIEW

*The speed and efficiency of the assembly process*

AIMCO's commitment to you doesn't end with the purchase of our tools. Our goal is to educate you and your team on the most effective and efficient ways to utilize our tools; therefore, consistently producing a quality product.

One of the many benefits of purchasing AIMCO tools is the opportunity to attend our Tool-U training. AIMCO believes this is one of the greatest assets we can offer you. AIMCO has spent valuable time

and dollars in setting up a training program at our corporate headquarters in Portland, Oregon, that will enable your team to receive effective technical and practical training. Our training program is not performed in just one corner of our facility; virtually our entire facility is accessed for training individuals tailored to their specific needs and applications. This is essential for the continued success of our training.



# Tool University Training

The objective of the Tool-U program is to train your team from a technical aspect, learning how to effectively trouble shoot in order to reduce down time, as well as testing and proper use of the tool for maximum performance.

We do not depend on just one individual to train our customers; AIMCO utilizes a team of experts to share their knowledge with you. Our training programs have been designed to cover all elements influencing the fastening process. The first key to

success is understanding the mechanics of the fastened joint; AIMCO then explores the synergy between the joint, power tool, torque measurement and operator handling. The knowledge you gain from participating in the Tool University program can be applied to almost any assembly process regardless of the tool brand.

AIMCO is so committed to ensuring you receive proper training that this program is offered to our customers at no charge.



# SERVICE

## OVERVIEW

*The speed and efficiency of the assembly process*

AIMCO's Technical and Repair Service departments are one of the biggest value adds in the industry. We don't just work for you, we work with you. AIMCO's Repair and Technical Field Services provide support unmatched by our competitors. Our skilled technicians work closely with our Technical Services group, as well as our expert team of engineers, to share knowledge, keep up with new technologies, and improve processes.



## GUARANTEED

*The relationship between assembler and the assembly process*

When AIMCO receives tools and equipment for servicing, they are pre-tested and inspected to identify issues and provide pertinent feedback to the user on getting the most out of their tool investment. We provide precise repair estimates giving the best value for your money. Repairs are completed using factory standards, parts, and processes. Once a repair is complete, it is tested, and/or calibrated, using N.I.S.T. certified measuring equipment, and guaranteed to perform to factory specifications.







# ACRADYNE® iEC CONTROLLER



## FEATURES AND BENEFITS

- Data Storage – Standard units store 2,040 rundowns. 10 million rundowns or more are possible with advanced network capable units.
- ToolWare – Custom designed software application means no licensing fees.
- Backwards Compatible – Works with any AcraDyne® DC tool.
- Parameter Set Select and Indication – Change operations and clear indication of your current operations with one button.
- External Port Software Updates – Plug-in capability for software updates.
- Tool Calibration Routines – Stores the calibration directly in the tool's memory for easy plug and play into any AcraDyne controller.
- Rundown Storage – Data stored for the last 2,048 rundowns can be viewed as raw data or graphed with statistical information. This data can also be saved in .csv format and opened directly with MicroSoft® Excel or other programs.
- Programmable Torque Filter Frequency – Satisfies customer specific filter requirements.
- Programmable Calibration and Service Interval Alerts – Configure alerts to indicate service or calibration due for a tool based on number of cycles or months since the last service or calibration.
- Real Time Clock – For time and date stamping, rundown information and other logged data.
- Bar Code Scanning.
- Network Capabilities – Capable of interfacing with plant controls.
- Graphing Capabilities – To track and monitor tightening strategies.
- Multiple Fastening Strategies – Program up to 32 parameter sets to handle 32 different torques and types of joints or link them for multi-step capabilities.
- Connection Capabilities – Connects with Parallel (legacy), USB or Ethernet.



## NETWORK CAPABILITIES AND ADVANCED FEATURES

- Network Compatible with the following protocols: PROFIBUS, DeviceNET, Open Protocol, Modbus TCP and PFCS.
- 10 Million Rundown Storage Capacity.
- Data Retrieval using standard FTP methods.
- Toolware management software accessible through Ethernet and is port selectable.
- Real time ascii text string of data accessible through Ethernet port.
- Static IP addressable.
- Parameter selection can be made through serial port and/or through use of bar code readers.

# ACRADYNE® iEC CONTROLLER

## ACCURATE

- Controlled tightening improves quality.
- Process controls ensure no missed screws, stripped threads, re-hits or damaged threads.
- Reduces human error.
- Consistent torque control.
- Accurate tightening means better end product quality.
- No premature shut-off.

## RELIABLE

- Reliable and accurate assembly - no guess work.
- Automatically set your torque and reduce operator error.
- No counting required.
- Collect and analyze your production data.

## PRODUCTIVE

- Increased productivity means increased profits.
- Replace up to eight conventional tools with one controlled system.
- Quieter operation.
- No oil contamination from air tool exhaust.

## CONTROL STRATEGIES (CW OR CCW)

- Torque Control (TC) – Provides target torque with high and low limits with simple pass or fail criteria for tightening threaded fasteners.
- Torque Control with Angle Monitoring (TC/AM) – For tightening threaded fasteners, allows you to monitor angle and rotation to detect any changes in the joint rate which would indicate process problems.
- Torque Monitoring with Angle Control (TM/AC) – For controlling the amount of fastener rotation.
- Torque Control and Angle Control (TC/AC) – Providing both torque and angle targets, and high and low limits, further refining the pass or fail criteria for critical applications.

## ADVANCED CONTROL FEATURES

- Start Delay – Allows the controller to ignore initial torque reading for a period of time to aid in thread cutting fasteners, prevailing load, and high inertial load applications.
- Rundown Back-off Rundown (RBR) Strategies – Used when joint conditioning is required. The controller runs to an initial torque, reverses to a pre-programmed angle, and then rundown to final torque.
- Rundown Back-off (RB) Strategies – Allows the tool to rundown to an initial torque, then reverse to a pre-programmed angle.
- Tubenut Control – Runs a tubenut wrench to torque, then returns to the home position when the run command is removed. A patented safety algorithm reduces the risk of pinch point injury.

Model	Standard Features	KDM	Serial Port Rs232	24V I/O	Additional Serial Port(s)	Ethernet	DeviceNET	PROFIBUS	Ethernet #2
IEC352	X		X	X					
IEC352K	X	X	X	X					
IEC353	X		X	X	2	X			
IEC353K	X	X	X	X	2	X			
IEC354E	X		X	X	2	X			X
IEC354D	X		X	X	1	X	X		
IEC354P	X		X	X	1	X		X	
IEC354KE	X	X	X	X	2	X			X
IEC354KD	X	X	X	X	1	X	X		
IEC354KP	X	X	X	X	1	X		X	

# ACRADYNE® iEC CONTROLLER

## NETWORK CONNECTIVITY

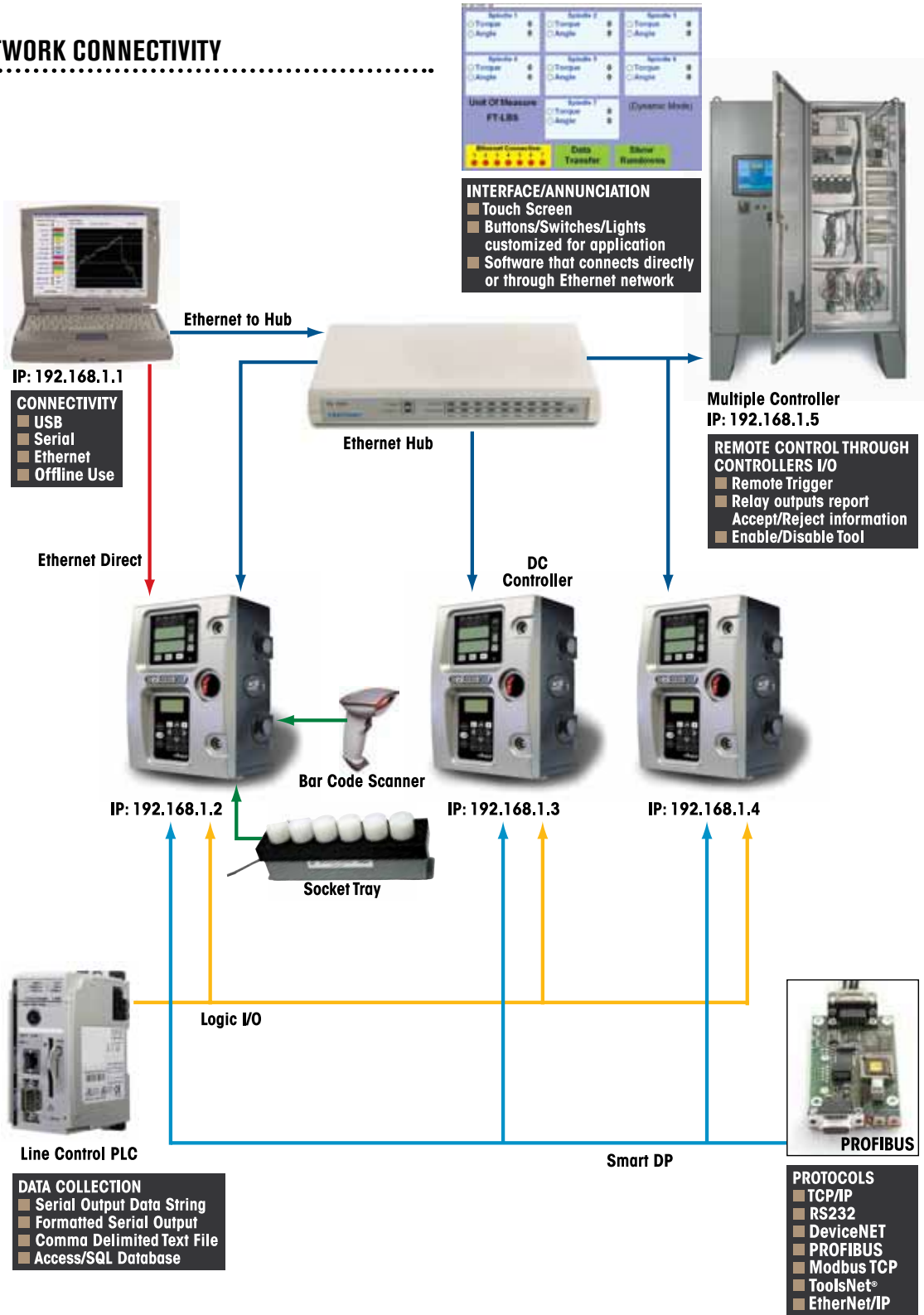

## TOOLWARE

ToolWare is AcraDyne's software package designed specifically for AcraDyne® tools and controllers. Provided at no cost to all users, this comprehensive, user friendly program allows programming, analysis and diagnostics via Ethernet, USB or parallel connection to any Windows® computer workstation. The software automatically detects the controller or can be used offline.

### EASY PARAMETER SET SET-UP



Adding and editing parameter sets is simple with ToolWare Intuitive Parameter Set-up Function.

### CURVEWARE™

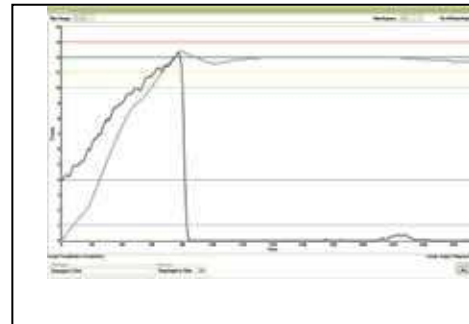

With CurveWare™, fast access to torque and angle curves allows the tool and controller to be programmed for optimal performance on any application.

### STATISTICS

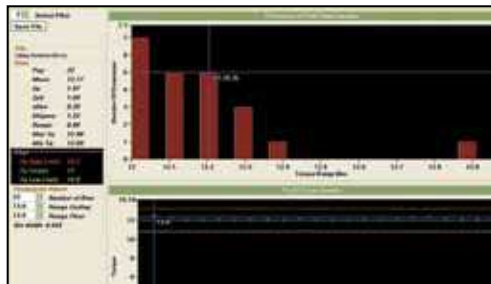

Vital statistics and rundown plots can be quickly viewed to assure the assembly process is being performed properly.

### BATCH PROCESSING



Whether simple or complex, batch jobs can be quickly set up using a variety of programming options.

### I/O MONITOR



For testing and visualization of processes, the I/O Monitor feature allows fast and informative observation of the controller's Fixed Logic I/O.

### CALIBRATION MAINTENANCE SCHEDULING



Programmable intervals and alerts provide immediate notice that the tool and/or controller are in need of scheduled preventive maintenance or calibration.

# ACRADYNE® 1000 SERIES NUTRUNNERS

## FEATURES AND BENEFITS

Superior -

- Size
- Speed
- Duty Cycle

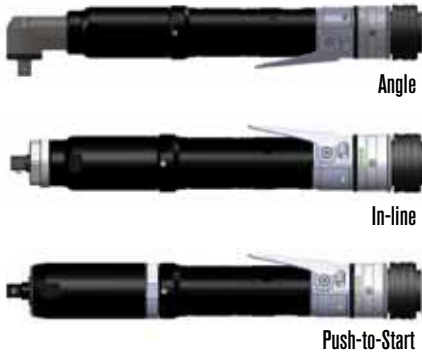

## APPLICATION DATA

1000 SERIES	NM	MAX TORQUE	FT-LB	NM	TORQUE RANGE	FT-LB	FREE SPEED RPM	LB	WEIGHT (-) SOCKET	KG	OUTPUT DRIVE
<b>ANGLE*</b>											
AEN4B12004B(Q)	4		3	1 - 4		0.7 - 3	3,111	2.0		0.91	1/4 Q.C.
AEN4C12009B(F)	9		6.6	2.3 - 9		1.7 - 6.6	1,750	2.2		1.00	3/8 SQ. DR.
AEN4C12014B(F)	14		10.3	3.5 - 14		2.6 - 10.3	875	2.2		1.00	3/8 SQ. DR.
AEN4C12018B(F)	18		13.3	4.5 - 18		3.3 - 13.3	691	2.2		1.00	3/8 SQ. DR.
AEN4C12022B(F)	22		16.2	5.5 - 22		4.1 - 16.2	560	2.2		1.00	3/8 SQ. DR.
<b>IN-LINE**</b>											
AES4A12003B(V)(Q)	3		2.2	0.8 - 3		0.6 - 2.2	2,625	2.0		0.91	3/8 SQ. DR.
AES4A12006B(V)(Q)	6		4.4	1.5 - 6		1.1 - 4.4	2,625	2.0		0.91	3/8 SQ. DR.
AES4A12011B(V)	11		8.1	2.8 - 11		2 - 8.1	1,313	2.2		1.00	3/8 SQ. DR.
AES4A12014B(V)	14		10.3	3.5 - 14		2.6 - 10.3	1,037	2.2		1.00	3/8 SQ. DR.
AES4A12018B(V)	18		13.3	4.5 - 18		3.3 - 13.3	840	2.2		1.00	3/8 SQ. DR.
AES4A12022B(V)	22		16.2	5.5 - 22		4.1 - 16.2	656	2.2		1.00	3/8 SQ. DR.
<b>PUSH-TO-START</b>											
AEL4A12003B	3		2.2	0.8 - 3		0.6 - 2.2	2,625	2.0		0.91	3/8 SQ. DR.
AEL4A12006B	6		4.4	1.5 - 6		1.1 - 4.4	2,625	2.0		0.91	3/8 SQ. DR.
AEL4A12011B	11		8.1	2.8 - 11		2 - 8.1	1,313	2.2		1.00	3/8 SQ. DR.
AEL4A12014B	14		10.3	3.5 - 14		2.6 - 10.3	1,037	2.2		1.00	3/8 SQ. DR.
AEL4A12018B	18		13.3	4.5 - 18		3.3 - 13.3	840	2.2		1.00	3/8 SQ. DR.
AEL4A12022B	22		16.2	5.5 - 22		4.1 - 16.2	656	2.2		1.00	3/8 SQ. DR.
<b>FIXTURED***</b>											
AEF4(A)(C)(X)12003B(B)	3		2.2	0.8 - 3		0.6 - 2.2	2,625	2.0		0.91	3/8 SQ. DR.
AEF4(A)(C)(X)12006B(B)	6		4.4	1.5 - 6		1.1 - 4.4	2,625	2.0		0.91	3/8 SQ. DR.
AEF4(A)(C)(X)12011B(B)	11		8.1	2.8 - 11		2 - 8.1	1,313	2.2		1.00	3/8 SQ. DR.
AEF4(A)(C)(X)12014B(B)	14		10.3	3.5 - 14		2.6 - 10.3	1,037	2.2		1.00	3/8 SQ. DR.
AEF4(A)(C)(X)12018B(B)	18		13.3	4.5 - 18		3.3 - 13.3	840	2.2		1.00	3/8 SQ. DR.
AEF4(A)(C)(X)12022B(B)	22		16.2	5.5 - 22		4.1 - 16.2	656	2.2		1.00	3/8 SQ. DR.

\* Add "F" to part numbers for flush socket.

\*\* Add "Q" to part number for quick change output. "V" indicates extended Ergo-Drive output.

\*\*\* Add "A" to part numbers for 1/2" sliding spindle models. Add "C" to part numbers for 1-3/4" sliding spindle models. Add "X" to part numbers for fixed 3/8" square drive output models.

\*\*\* Add "B" part numbers for bottom exit cable.

# ACRADYNE® 1000 SERIES NUTRUNNERS

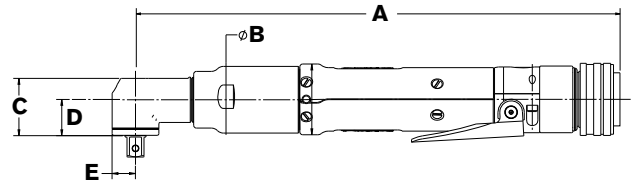

## DIMENSIONS

ANGLE	IN	(A)	MM	IN	(B)	MM	IN	(C)	MM	IN	(D)	MM	IN	(E)	MM
AEN4B12004B	11.65		295.9	1.47		37.3	.98		24.8	.62		15.8	.40		10.2
AEN4C12009B	11.00		279.5	1.47		37.3	1.29		32.8	.82		20.9	.52		13.1
AEN4C12014B	11.66		296.4	1.47		37.3	1.29		32.8	.82		20.9	.52		13.1
AEN4C12018B	11.66		296.4	1.47		37.3	1.29		32.8	.82		20.9	.52		13.1
AEN4C12022B	11.66		296.4	1.47		37.3	1.29		32.8	.82		20.9	.52		13.1

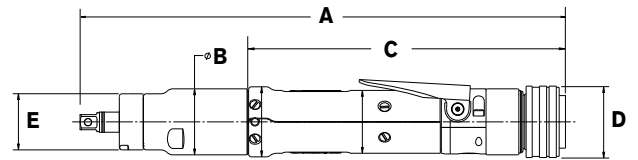

## DIMENSIONS

IN-LINE	IN	(A)	MM	IN	(B)	MM	IN	(C)	MM	IN	(D)	MM	IN	(E)	MM
AES4A12003B	11.12		282.7	1.47		37.3	7.38		187.5	1.59		40.4	1.25		31.8
AES4A12006B	11.12		282.7	1.47		37.3	7.38		187.5	1.59		40.4	1.25		31.8
AES4A12011B	11.44		290.5	1.47		37.3	7.38		187.5	1.59		40.4	1.25		31.8
AES4A12014B	11.44		290.5	1.56		39.6	7.38		187.5	1.59		40.4	1.25		31.8
AES4A12018B	11.44		290.5	1.47		37.3	7.38		187.5	1.59		40.4	1.25		31.8
AES4A12022B	11.44		290.5	1.47		37.3	7.38		187.5	1.59		40.4	1.25		31.8
PUSH-TO-START	IN	(A)	MM	IN	(B)	MM	IN	(C)	MM	IN	(D)	MM	IN	(E)	MM
AEL4A12003B	11.31		287.3	1.56		39.6	7.38		187.5	1.59		40.4	1.25		31.8
AEL4A12006B	11.32		287.4	1.56		39.6	7.38		187.5	1.59		40.4	1.25		31.8
AEL4A12011B	11.62		295.4	1.56		39.6	7.38		187.5	1.59		40.4	1.25		31.8
AEL4A12014B	11.62		295.4	1.56		39.6	7.38		187.5	1.59		40.4	1.25		31.8
AEL4A12018B	11.62		295.4	1.56		39.6	7.38		187.5	1.59		40.4	1.25		31.8
AEL4A12022B	11.62		295.4	1.56		39.6	7.38		187.5	1.59		40.4	1.25		31.8

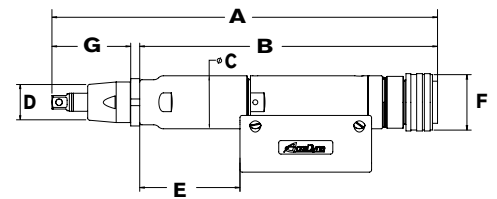

## DIMENSIONS

FIXTURED	IN	(A)	MM	IN	(B)	MM	IN	(C)	MM	IN	(D)	MM	IN	(E)	MM	IN	(F)	MM	IN	(G)	MM
AEF4A12003B	11.53		292.9	9.10		231.04	1.47		37.3	1.13		28.57	2.06		52.2	1.59		40.4	2.18		55.5
AEF4A12006B	11.53		292.9	9.10		231.04	1.47		37.3	1.13		28.57	2.06		52.2	1.59		40.4	2.18		55.5
AEF4A12011B	12.20		309.8	9.10		231.04	1.47		37.3	1.13		28.57	2.72		69.1	1.59		40.4	2.18		55.5
AEF4A12014B	12.20		309.8	9.10		231.04	1.47		37.3	1.13		28.57	2.72		69.1	1.59		40.4	2.18		55.5
AEF4A12018B	12.20		309.8	9.10		231.04	1.47		37.3	1.13		28.57	2.72		69.1	1.59		40.4	2.18		55.5
AEF4A12022B	12.20		309.8	9.10		231.04	1.47		37.3	1.13		28.57	2.72		69.1	1.59		40.4	2.18		55.5
AEF4C12003B	15.32		389.2	9.10		231.04	1.47		37.3	1.13		28.57	2.06		52.2	1.59		40.4	5.98		151.8
AEF4C12006B	15.32		389.2	9.10		231.04	1.47		37.3	1.13		28.57	2.06		52.2	1.59		40.4	5.98		151.8
AEF4C12011B	15.99		406.1	9.10		231.04	1.47		37.3	1.13		28.57	2.72		69.1	1.59		40.4	5.98		151.8
AEF4C12014B	15.99		406.1	9.10		231.04	1.47		37.3	1.13		28.57	2.72		69.1	1.59		40.4	5.98		151.8
AEF4C12018B	15.99		406.1	9.10		231.04	1.47		37.3	1.13		28.57	2.72		69.1	1.59		40.4	5.98		151.8
AEF4C12022B	15.99		406.1	9.10		231.04	1.47		37.3	1.13		28.57	2.72		69.1	1.59		40.4	5.98		151.8
AEF4X12003B	9.35		237.5	9.10		231.04	1.47		37.3	1.13		28.57	2.06		52.2	1.59		40.4	.80		20.4
AEF4X12006B	9.35		237.5	9.10		231.04	1.47		37.3	1.13		28.57	2.06		52.2	1.59		40.4	.80		20.4
AEF4X12011B	10.00		254.4	9.10		231.04	1.47		37.3	1.13		28.57	2.72		69.1	1.59		40.4	.80		20.4
AEF4X12014B	10.00		254.4	9.10		231.04	1.47		37.3	1.13		28.57	2.72		69.1	1.59		40.4	.80		20.4
AEF4X12018B	10.00		254.4	9.10		231.04	1.47		37.3	1.13		28.57	2.72		69.1	1.59		40.4	.80		20.4
AEF4X12022B	10.00		254.4	9.10		231.04	1.47		37.3	1.13		28.57	2.72		69.1	1.59		40.4	.80		20.4

# ACRADYNE® PISTOL GRIP NUTRUNNERS

## FEATURES AND BENEFITS

- Cable configurations available in rear exit, bottom exit, or right angle exit.
- Configured with AcraDyne's multi-function button (MFB) enabling flexibility in operation.
- On board lights and audible signal for operator feedback.



Top Exit Cable



Rear Exit Cable



Bottom Exit Cable

## APPLICATION DATA

1000 SERIES*	NM	MAX TORQUE	FT-LB	NM	TORQUE RANGE	FT-LB	FREE SPEED RPM	LB	WEIGHT (-) SOCKET	KG	OUTPUT DRIVE
AEP4(A)(R)(T)12003B(V)(Q)	3		2.2	0.8 - 3		0.6 - 2.2	2,625	2.2		1.00	3/8 SQ. DR.*
AEP4(A)(R)(T)12006B(V)(Q)	6		4.4	1.5 - 6		1.1 - 4.4	2,625	2.2		1.00	3/8 SQ. DR.*
AEP4(A)(R)(T)12011B(V)(Q)	11		8.1	2.8 - 11		2 - 8.1	1,313	2.3		1.04	3/8 SQ. DR.
AEP4(A)(R)(T)12014B(V)(Q)	14		10.3	3.5 - 14		2.6 - 10.3	1,037	2.3		1.04	3/8 SQ. DR.
AEP4(A)(R)(T)12018B(V)	18		13.3	4.5 - 18		3.3 - 13.3	840	2.3		1.04	3/8 SQ. DR.
AEP4(A)(R)(T)12022B(V)	22		16.2	5.5 - 22		4.1 - 16.2	656	2.3		1.04	3/8 SQ. DR.
2000 SERIES*	NM	MAX TORQUE	FT-LB	NM	TORQUE RANGE	FT-LB	FREE SPEED RPM	LB	WEIGHT (-) SOCKET	KG	OUTPUT DRIVE
AEP4(A)(R)(T)22020B(V)	20		14.8	5 - 20		3.7 - 14.8	1,313	2.4		1.09	3/8 SQ. DR.
AEP4(A)(R)(T)22025B(V)	25		18.4	6.3 - 25		4.6 - 18.4	1,037	2.4		1.09	3/8 SQ. DR.
AEP4(A)(R)(T)22030B(V)	30		22.0	7.5 - 30		5.5 - 22.0	840	2.4		1.09	3/8 SQ. DR.
AEP4(A)(R)(T)22035B(V)	35		25.8	8.8 - 35		6.5 - 25.8	747	2.4		1.09	3/8 SQ. DR.
AEP4(A)(R)(T)22040B(V)	40		29.5	10 - 40		7.4 - 29.5	656	2.4		1.09	3/8 SQ. DR.

\* Add "Q" to part numbers for 1/4" quick change output standard

Add "A" to part numbers for bottom exit cable models,

Add "R" to part numbers for rear exit cable models,

Add "T" to part numbers for top exit cable models,

Add "V" to part numbers for extended Ergo-Drive output.

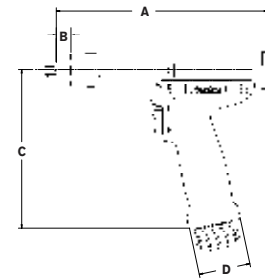

## DIMENSIONS

1000 SERIES	IN	(A)	MM	IN	(B)	MM	IN	(C)	MM	IN	(D)	MM
AEP412003B	7.34		186.3	0.54		13.7	6.01		152.6	1.96		49.7
AEP412006B	7.34		186.3	0.54		13.7	6.01		152.6	1.96		49.7
AEP412011BV	8.00		203.3	0.54		13.7	6.01		152.6	1.96		49.7
AEP412014BV	8.00		203.3	0.54		13.7	6.01		152.6	1.96		49.7
AEP412018BV	8.00		203.3	0.54		13.7	6.01		152.6	1.96		49.7
AEP412022BV	8.00		203.3	0.54		13.7	6.01		152.6	1.96		49.7
2000 SERIES	IN	(A)	MM	IN	(B)	MM	IN	(C)	MM	IN	(D)	MM
AEP422020B	8.66		219.9	0.56		14.2	6.87		174.4	1.96		49.7
AEP422025B	8.66		219.9	0.56		14.2	6.87		174.4	1.96		49.7
AEP422030B	8.66		219.9	0.56		14.2	6.87		174.4	1.96		49.7
AEP422035B	8.66		219.9	0.56		14.2	6.87		174.4	1.96		49.7
AEP422040B	8.66		219.9	0.56		14.2	6.87		174.4	1.96		49.7

# ACRADYNE® PISTOL GRIP NUTRUNNERS



AEP35075AV  
AEP35090AV  
AEP35110AV  
AEP35135AV  
AEP35170AV



AEP35280A  
AEP35350A  
AEP35420A  
AEP35515A  
AEP35635A

## APPLICATION DATA

5000 SERIES	NM	MAX TORQUE	FT-LB	NM	TORQUE RANGE	FT-LB	FREE SPEED RPM	LB	WEIGHT (-) SOCKET	KG	OUTPUT DRIVE
AEP35075A(V)(T)	75		55.4	19 - 75		14 - 55.4	944	9.2		4.17	1/2 SQ. DR.
AEP35090A(V)(T)	90		66.4	23 - 90		17 - 66.4	767	9.2		4.17	1/2 SQ. DR.
AEP35110A(V)(T)	110		81.2	28 - 110		20.7 - 81.2	634	9.2		4.17	1/2 SQ. DR.
AEP35135A(V)(T)	135		99.6	34 - 135		25.1 - 99.6	515	9.2		4.17	1/2 SQ. DR.
AEP35170A(V)(T)	170		125.5	43 - 170		31.7 - 125.5	418	9.2		4.17	1/2 SQ. DR.
AEP35280A(T)	280		206.6	70 - 280		51.7 - 206.6	236	13.6		6.17	3/4 SQ. DR.
AEP35350A(T)	350		258.3	88 - 350		64.9 - 258.3	192	13.6		6.17	3/4 SQ. DR.
AEP35420A(T)	420		310	105 - 420		77.5 - 310	159	13.6		6.17	3/4 SQ. DR.
AEP35515A(T)	515		380.1	128 - 515		94.5 - 380.1	129	13.6		6.17	3/4 SQ. DR.
AEP35635A(T)	635		468.6	159 - 635		117.3 - 468.6	104	13.6		6.17	3/4 SQ. DR.

Add "V" to part numbers for extended Ergo-Drive output.  
Add "T" to part numbers for top exit cable models.

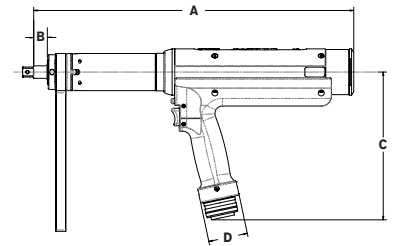

## DIMENSIONS

5000 SERIES	IN	(A)	MM	IN	(B)	MM	IN	(C)	MM	IN	(D)	MM
AEP35075AV	15.95		405.2	.68		17.4	7.37		187.1	1.96		49.7
AEP35090AV	15.95		405.2	.68		17.4	7.37		187.1	1.96		49.7
AEP35110AV	15.95		405.2	.68		17.4	7.37		187.1	1.96		49.7
AEP35135AV	15.95		405.2	.68		17.4	7.37		187.1	1.96		49.7
AEP35170AV	15.95		405.2	.68		17.4	7.37		187.1	1.96		49.7
AEP35280A	18.43		468.2	1.11		28.1	7.37		187.1	1.96		49.7
AEP35350A	18.43		468.2	1.11		28.1	7.37		187.1	1.96		49.7
AEP35420A	18.43		468.2	1.11		28.1	7.37		187.1	1.96		49.7
AEP35515A	18.43		468.2	1.11		28.1	7.37		187.1	1.96		49.7
AEP35635A	18.43		468.2	1.11		28.1	7.37		187.1	1.96		49.7



# ACRADYNE® ANGLE NUTRUNNERS

## FEATURES AND BENEFITS

AcraDyne® angle nutrunners provide a solution to space-limited fastening applications that are not practical with inline or pistol model tools. A compact, durable head houses a precision right angle gear set which fits into the tightest of spaces and delivers a highly accurate fastening cycle. Lightweight materials and a uniform body diameter provide a comfortable grip and an ergonomically placed start lever allows for simple control. AcraDyne® angle nutrunners offer the perfect solution for any handheld, precision fastening application.



## APPLICATION DATA

2000 SERIES*	NM	MAX TORQUE	FT-LB	NM	TORQUE RANGE	FT-LB	FREE SPEED RPM	LB	WEIGHT (-) SOCKET	KG	OUTPUT DRIVE
AEN32015B(F)(DL)	15		11.0	3 - 12		2.2 - 8.9	1,481	2.7		1.22	3/8 SQ. DR.
AEN32025B(F)(DL)	25		18.0	5 - 20		3.7 - 14.8	833	2.7		1.22	3/8 SQ. DR.
AEN32030B(F)(DL)	30		22.0	6 - 24		4.4 - 17.7	803	2.8		1.27	3/8 SQ. DR.
AEN32040B(F)(DL)	40		29.5	8 - 32		5.9 - 23.6	574	2.8		1.27	3/8 SQ. DR.
3000 SERIES*	NM	MAX TORQUE	FT-LB	NM	TORQUE RANGE	FT-LB	FREE SPEED RPM	LB	WEIGHT (-) SOCKET	KG	OUTPUT DRIVE
AEN33042B(F)(DL)	42		31	9.5 - 38		7 - 28	1,095	4.4		2.00	3/8 SQ. DR.
AEN33053B(F)(DL)	53		39.1	12 - 48		8.9 - 35.4	1,095	4.4		2.00	3/8 SQ. DR.
AEN33060B(F)(DL)	60		44	12 - 48		8.9 - 35.4	845	6.6		2.99	1/2 SQ. DR.
AEN33090B(F)(DL)	90		66	18 - 72		13.2 - 53.1	568	6.6		2.99	1/2 SQ. DR.
AEN33120B(F)(DL)	120		88.5	24 - 96		17.7 - 70.8	442	9.3		4.22	1/2 SQ. DR.
AEN33200B(F)(DL)	200		147.5	40 - 160		29.5 - 118	245	9.4		4.26	3/4 SQ. DR.
AEN33300B(F)(DL)	300		221	60 - 240		44.2 - 177	151	10.0		4.54	3/4 SQ. DR.

\* Add "F" to part numbers for flush socket.  
Add "DL" to part numbers for double levers.

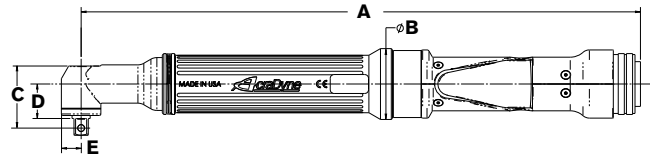

## DIMENSIONS

2000 SERIES	IN	(A)	MM	IN	(B)	MM	IN	(C)	MM	IN	(D)	MM	IN	(E)	MM
AEN32015B	14.61		371	1.85		47	1.37		34.8	.90		22.9	.52		13.1
AEN32025B	14.61		371	1.85		47	1.37		34.8	.90		22.9	.52		13.1
AEN32030B	14.42		366.2	1.85		47	1.65		41.8	1.16		29.4	.70		17.8
AEN32040B	14.42		366.2	1.85		47	1.65		41.8	1.16		29.4	.70		17.8
3000 SERIES	IN	(A)	MM	IN	(B)	MM	IN	(C)	MM	IN	(D)	MM	IN	(E)	MM
AEN33042B	16.63		422.33	1.85		47	1.66		42.11	1.17		29.67	.7		17.78
AEN33053B	16.63		422.33	1.85		47	1.66		42.11	1.17		29.67	.7		17.78
AEN33060B	18.92		480.53	1.85		47	1.90		48.36	1.37		34.90	.83		20.96
AEN33090B	18.92		480.53	1.85		47	1.90		48.36	1.37		34.90	.83		20.96
AEN33120B	21.00		533.46	1.85		47	2.78		70.59	2.08		52.81	1.05		26.67
AEN33200B	23.21		589.64	1.85		47	2.59		65.75	1.89		47.98	1.05		26.67
AEN33300B	23.58		598.88	1.85		47	2.90		73.53	1.97		50.04	1.25		31.75

# ACRADYNE® ANGLE NUTRUNNERS



AEN 5000 Series Models

## APPLICATION DATA

5000 SERIES	NM	MAX TORQUE	FT-LB	NM	TORQUE RANGE	FT-LB	FREE SPEED RPM	LB	WEIGHT (-) SOCKET	KG	OUTPUT DRIVE
AEN35090A(F)	90		66.4	23 - 90		17 - 66.4	607	6.9		3.13	1/2 SQ. DR.
AEN35140A(F)	140		103.3	35 - 140		25.8 - 103.3	472	10.4		4.72	3/4 SQ. DR.
AEN35175A(F)	175		129.1	44 - 175		32.5 - 129.1	384	10.5		4.76	3/4 SQ. DR.
AEN35225A(F)	225		166	56 - 225		41.3 - 166	291	12.3		5.58	3/4 SQ. DR.
AEN35285A(F)	285		210.2	71 - 285		52.4 - 210.2	236	12.3		5.58	3/4 SQ. DR.
AEN35350A(F)	350		258.3	88 - 350		64.5 - 258.3	191	12.3		5.58	3/4 SQ. DR.

Add "F" to part numbers for flush socket.

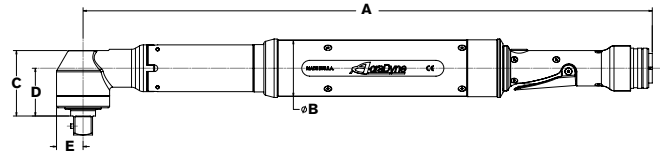

## DIMENSIONS

5000 SERIES	IN	(A)	MM	IN	(B)	MM	IN	(C)	MM	IN	(D)	MM	IN	(E)	MM
AEN35090A	22.59		573.7	2.31		58.7	1.90		48.4	1.37		34.9	.81		20.6
AEN35140A	22.52		571.9	2.31		58.7	2.59		65.8	1.89		48	1.05		26.7
AEN35175A	22.52		571.9	2.31		58.7	2.59		65.8	1.89		48	1.05		26.7
AEN35225A	22.88		581.1	2.31		58.7	2.90		73.5	1.97		50	1.25		31.8
AEN35285A	22.88		581.1	2.31		58.7	2.90		73.5	1.97		50	1.25		31.8
AEN35350A	22.88		581.1	2.31		58.7	2.90		73.5	1.97		50	1.25		31.8

# ACRADYNE® IN-LINE NUTRUNNERS

## FEATURES AND BENEFITS

AcraDyne® inline nutrunners are the perfect choice for fixtured fastening applications because of their compact size and durability. A uniform body diameter and a hex shaped mounting point allow for simple installation into fixture plates. Simply machine a female hex into a steel plate, insert the nutrunner, secure with the factory supplied nut and your fastening machine is assembled. A reaction bar for use in handheld applications is also included with all AcraDyne® inline nutrunners.



AES 2000 Series Models

AES 3000 Series Models

## APPLICATION DATA

2000 SERIES*	NM	MAX TORQUE	FT-LB	NM	TORQUE RANGE	FT-LB	FREE SPEED RPM	LB	WEIGHT (-) SOCKET	KG	OUTPUT DRIVE
AES32010B(V)(Q)	10		7.4	2 - 8		1.5 - 5.9	2,222	2.5		1.13	3/8 SQ. DR.*
AES32020B(V)(Q)	20		14.8	4 - 16		3.0 - 11.8	1,250	2.5		1.13	3/8 SQ. DR.*
AES32025B(V)(Q)	25		18.4	5 - 20		3.7 - 14.8	893	3.2		1.45	3/8 SQ. DR.*
AES32038B(V)	38		28.0	7.5 - 30		5.5 - 22.1	595	4.2		1.91	3/8 SQ. DR.
3000 SERIES*	NM	MAX TORQUE	FT-LB	NM	TORQUE RANGE	FT-LB	FREE SPEED RPM	LB	WEIGHT (-) SOCKET	KG	OUTPUT DRIVE
AES33040B(V)(-2)	40		29.5	8 - 32		5.9 - 23.6	1,314	6.4		2.90	1/2 SQ. DR.
AES33060B(V)(-2)	60		44.0	12 - 48		8.9 - 35.4	883	6.4		2.90	1/2 SQ. DR.
AES33100B(V)(-2)	100		73.8	20 - 80		14.75 - 59.0	489	8.1		3.67	1/2 SQ. DR.
AES33150B(V)(-2)	150		110.6	30 - 120		22.1 - 88.5	329	8.1		3.67	1/2 SQ. DR.
AES33230B(V)(-2)	230		169.6	46 - 184		33.9 - 135.7	221	8.1		3.67	1/2 SQ. DR.
AES33400B(V)(-2)	400		295	80 - 320		59 - 236	122	13.0**		5.90**	3/4 SQ. DR.
AES33600B(V)(-2)	600		440	120 - 480		89 - 354	82	13.0**		5.90**	3/4 SQ. DR.

\* Add "Q" to part numbers for 1/4" quick change output standard. Add "V" to part numbers for standard spindle models. Add "-2" to part numbers for 2" sliding spindle models.

\*\*Including reaction bar and fixture nut

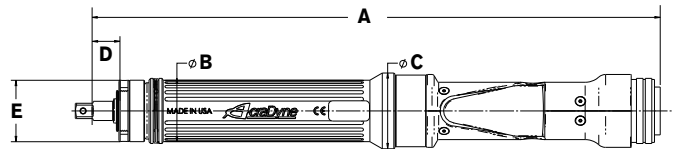

## DIMENSIONS

2000 SERIES	IN	(A)	MM	IN	(B)	MM	IN	(C)	MM	IN	(D)	MM	IN	(E)	MM
AES32010B	13.85		351.7	1.59		40.4	1.85		47	.56		14.3	1.50		38.1
AES32020B	13.85		351.7	1.59		40.4	1.85		47	.56		14.3	1.50		38.1
AES32025B	13.85		351.7	1.59		40.4	1.85		47	.56		14.3	1.50		38.1
AES32038B	16.69		424	1.50		38.1	1.85		47	.51		12.9	1.50		38.1
3000 SERIES	IN	(A)	MM	IN	(B)	MM	IN	(C)	MM	IN	(D)	MM	IN	(E)	MM
AES33040B	18.24		463.38	1.94		49.28	1.85		47	.68		17.17	1.85		47
AES33060B	18.24		463.38	1.94		49.28	1.85		47	.68		17.17	1.85		47
AES33100B	22.56		572.99	1.94		49.28	1.85		47	.68		17.17	1.85		47
AES33150B	22.56		572.99	1.94		49.28	1.85		47	.68		17.17	1.85		47
AES33230B	22.56		572.99	1.94		49.28	1.85		47	.68		17.17	1.85		47
AES33400B	24.90		532.36	1.94		49.28	1.85		47	1.11		28.08	2.64		67.1
AES33600B	24.90		532.36	1.94		49.28	1.85		47	1.11		28.08	2.64		67.1

# ACRADYNE® IN-LINE NUTRUNNERS



AES 5000 Series Models

## APPLICATION DATA

5000 SERIES	NM	MAX TORQUE	FT-LB	NM	TORQUE RANGE	FT-LB	FREE SPEED RPM	LB	WEIGHT (-) SOCKET	KG	OUTPUT DRIVE
AES35075A(V)	75	55.4	19 - 75	14 - 55.4	944	9.2	4.17	1/2 SQ. DR.			
AES35090A(V)	90	66.4	23 - 90	17 - 66.4	767	9.2	4.17	1/2 SQ. DR.			
AES35110A(V)	110	81.2	28 - 110	20.7 - 81.2	634	9.2	4.17	1/2 SQ. DR.			
AES35135A(V)	135	99.6	34 - 135	25.1 - 99.6	515	9.2	4.17	1/2 SQ. DR.			
AES35170A(V)	170	125.5	43 - 170	31.7 - 125.5	418	9.2	4.17	1/2 SQ. DR.			
AES35280A	280	206.6	70 - 280	51.7 - 206.6	236	12.8	5.81	3/4 SQ. DR.			
AES35350A	350	258.3	88 - 350	64.9 - 258.3	192	12.8	5.81	3/4 SQ. DR.			
AES35420A	420	310	105 - 420	77.5 - 310	159	12.8	5.81	3/4 SQ. DR.			
AES35515A	515	380.1	128 - 515	94.5 - 380.1	129	12.8	5.81	3/4 SQ. DR.			
AES35635A	635	468.6	159 - 635	117.3 - 468.6	104	12.8	5.81	3/4 SQ. DR.			

Add "V" to part numbers for extended Ergo-Drive output.

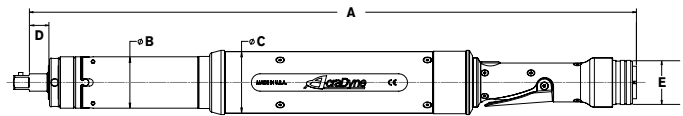

## DIMENSIONS

5000 SERIES	IN	(A)	MM	IN	(B)	MM	IN	(C)	MM	IN	(D)	MM	IN	(E)	MM
AES35075A	21.86	555.2	1.85	47	2.31	58.7	.68	17.4	1.78	45.2					
AES35090A	21.86	555.2	1.85	47	2.31	58.7	.68	17.4	1.78	45.2					
AES35110A	21.86	555.2	1.85	47	2.31	58.7	.68	17.4	1.78	45.2					
AES35135A	21.86	555.2	1.85	47	2.31	58.7	.68	17.4	1.78	45.2					
AES35170A	21.86	555.2	1.85	47	2.31	58.7	.68	17.4	1.78	45.2					
AES35280A	24.22	615.1	2.64	67.1	2.31	58.7	1.11	28.1	1.78	45.2					
AES35350A	24.22	615.1	2.64	67.1	2.31	58.7	1.11	28.1	1.78	45.2					
AES35420A	24.22	615.1	2.64	67.1	2.31	58.7	1.11	28.1	1.78	45.2					
AES35515A	24.22	615.1	2.64	67.1	2.31	58.7	1.11	28.1	1.78	45.2					
AES35635A	24.22	615.1	2.64	67.1	2.31	58.7	1.11	28.1	1.78	45.2					

# ACRADYNE® FIXTURED NUTRUNNERS



Standard Spindle, Rear Exit Cable



Standard Spindle, Bottom Exit Cable



2" Sliding Spindle, Rear Exit Cable



2" Sliding Spindle, Bottom Exit Cable

## APPLICATION DATA

5000 SERIES	NM	MAX TORQUE	FT-LB	NM	TORQUE RANGE	FT-LB	FREE SPEED RPM	LB	WEIGHT (-) SOCKET	KG	OUTPUT DRIVE
AEF35075A(V)(VB)(-2)(B-2)	75	55.3	19 - 75	14 - 55.3	944	9.6	4.35	1/2 SQ. DR.			
AEF35090A(V)(VB)(-2)(B-2)	90	66.4	23 - 90	17 - 66.4	767	9.6	4.35	1/2 SQ. DR.			
AEF35110A(V)(VB)(-2)(B-2)	110	81.1	28 - 110	20.7 - 81.1	634	9.6	4.35	1/2 SQ. DR.			
AEF35135A(V)(VB)(-2)(B-2)	135	99.6	34 - 135	25.1 - 99.6	515	9.6	4.35	1/2 SQ. DR.			
AEF35170A(V)(VB)(-2)(B-2)	170	125.4	43 - 170	31.7 - 125.4	418	9.6	4.35	1/2 SQ. DR.			

Add "V" to part numbers for standard spindle with rear exit cable models. Add "VB" to part numbers for standard spindle with bottom exit cable models.

Add "-2" to part numbers for 2" sliding spindle with rear exit cable models. Add "B-2" to part numbers for 2" sliding spindle with bottom exit cable models.

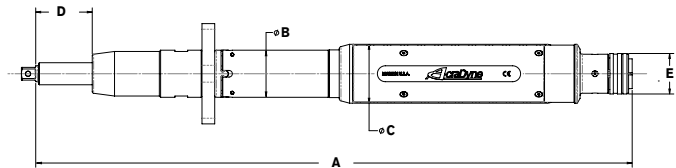

## DIMENSIONS

5000 SERIES	IN (A)	MM	IN (B)	MM	IN (C)	MM	IN (D)	MM	IN (E)	MM
AEF35075A	17.67	448.8	1.85	47	2.31	58.7	.72	18.4	1.59	40.4
AEF35090A	17.67	448.8	1.85	47	2.31	58.7	.72	18.4	1.59	40.4
AEF35110A	17.67	448.8	1.85	47	2.31	58.7	.72	18.4	1.59	40.4
AEF35135A	17.67	448.8	1.85	47	2.31	58.7	.72	18.4	1.59	40.4
AEF35170A	17.67	448.8	1.85	47	2.31	58.7	.72	18.4	1.59	40.4
AEF35075A	23.43	595.1	1.85	47	2.31	58.7	2.22	56.4	1.59	40.4
AEF35090A	23.43	595.1	1.85	47	2.31	58.7	2.22	56.4	1.59	40.4
AEF35110A	23.43	595.1	1.85	47	2.31	58.7	2.22	56.4	1.59	40.4
AEF35135A	23.43	595.1	1.85	47	2.31	58.7	2.22	56.4	1.59	40.4
AEF35170A	23.43	595.1	1.85	47	2.31	58.7	2.22	56.4	1.59	40.4

# ACRADYNE® TUBENUT NUTRUNNERS

## FEATURES AND BENEFITS

- Patented Safety Algorithm.
- Transducer senses resistance in the initial 90 degrees of rotation and returns to open upon any resistance encountered.
- Proven, durable Tubenut head design.
- Simple, one touch back to open operation for maximum productivity.



AET 2000 Series Model

AET 1000 Series Model

AET 2000 Series Model with Double Levers

WITH INNOVATIVE SAFETY SENSOR TECHNOLOGY!

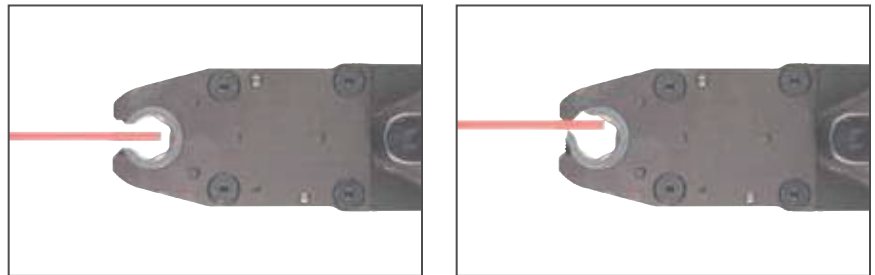

## APPLICATION DATA

1000 SERIES*	NM	MAX TORQUE	FT-LB	NM	TORQUE RANGE	FT-LB	FREE SPEED RPM	LB	WEIGHT (-) SOCKET	KG	IN	OUTPUT RIVE	MM
AET4A12018B(DL)	18	13.3	13.3	3.6 - 14.4	2.7 - 10.6	10.6	516	3.1	1.41	1.41	1/4 - 7/16	7 - 12	
AET4A12025B(DL)	25	18.4	18.4	5 - 20	3.7 - 14.8	14.8	387	3.1	1.41	1.41	3/8 - 5/8	10 - 17	
2000 SERIES*	NM	MAX TORQUE	FT-LB	NM	TORQUE RANGE	FT-LB	FREE SPEED RPM	LB	WEIGHT (-) SOCKET	KG	IN	OUTPUT RIVE	MM
AET32020B(DL)	20	14.8	14.8	4 - 16	3.0 - 11.8	11.8	622	3.1	1.41	1.41	1/4 - 7/16	7 - 12	
AET32025B(DL)	25	18.4	18.4	5 - 20	3.7 - 14.8	14.8	466	4.0	1.81	1.81	3/8 - 5/8	10 - 17	
AET32035B(DL)	35	25.8	25.8	7 - 28	5.2 - 20.7	20.7	347	4.5	2.04	2.04	1/2 - 7/8	13 - 24	
AET32050B(DL)	50	36.9	36.9	10 - 40	7.4 - 29.5	29.5	257	5.6	2.54	2.54	5/8 - 1-3/16	17 - 32	

\*Add "DL" to part numbers for double levers. Request specific socket size when placing your order. AIMCO offers a wide variety of socket sizes to fit your needs.

## SPECIALIZED HEADS

AIMCO is able to provide specialized heads for almost any application. Tubenut, Hold and Drive, Crow Foot, Offsets and Sliding Spindles are just a few of the head styles available. Let us know your requirements and we will help select the head configuration to get the job done.



# ACRADYNE® HOLD & DRIVE NUTRUNNERS

## FEATURES AND BENEFITS

- Torques Ranging from 20Nm – 200Nm.
- Very Robust modern design.
- 1" and 2" travels are standard.
- Sockets and holders are custom to order.



## APPLICATION DATA

MODEL*	NM	MAX TORQUE	FT-LB	NM	TORQUE RANGE	FT-LB	FREE SPEED RPM	WEIGHT LB		MIN/MAX SOCKET
AEH4F12020B(-1,2)	20		14.75	4 - 16		3.0 - 11.8	533	-1=2.8, -2=3.0		9/16 (14MM) / 13/16, (21MM)
AEH4F12026B(-1,2)	26		19.18	5.2 - 20.8		3.8 - 15.4	432	-1=2.8, -2=3.1		9/16 (14MM) / 13/16, (21MM)
AEH32025B(-1,2)	25		18.44	5 - 20		3.7 - 14.8	833	-1 = 3.5, -2 = 3.5		9/16 (14MM) / 13/16, (21MM)
AEH32030B(-1,2)	30		22.13	6 - 24		4.4 - 17.7	803	-1 = 3.5, -2 = 3.6		9/16 (14MM) / 13/16, (21MM)
AEH32040B(-1,2)	40		29.50	8 - 32		5.9 - 23.6	574	-1 = 3.5, -2 = 3.7		9/16 (14MM) / 13/16, (21MM)
AEH33053B(-1,2)	53		39.09	12 - 48		8.9 - 35.4	1,095	-1=5.6, -2=5.8		9/16 (14MM) / 13/16, (21MM)
AEH33060B(-1,2)	60		44.25	12 - 48		8.9 - 35.4	845	-1=7.3, -2=7.5		5/8 (16MM) / 1-1/4, (32MM)
AEH33090B(-1,2)	90		66.38	18 - 72		13.2 - 53.1	568	-1=7.3, -2=7.6		5/8 (16MM) / 1-1/4, (32MM)
AEH33120B(-1,2)	120		88.51	24 - 96		17.7 - 70.8	442	-1=10.0, -2=10.3		5/8 (16MM) / 1-1/4, (32MM)
AEH33200B(-1,2)	200		147.51	40 - 160		29.5 - 118	245	-1=10.0, -2=10.4		5/8 (16MM) / 1-1/4, (32MM)
AEH35140B(-1,2)	140		103.26	35 - 140		25.8 - 103.3	472	-1=10.6, -2=11.0		5/8 (16MM) / 1-1/4, (32MM)
AEH35175B(-1,2)	175		129.1	44 - 175		32.5 - 129.1	384	-1=10.6, -2=11.1		5/8 (16MM) / 1-1/4, (32MM)

\* Add "1" to part numbers for 1" travel. Add "2" to part numbers for 2" travel.

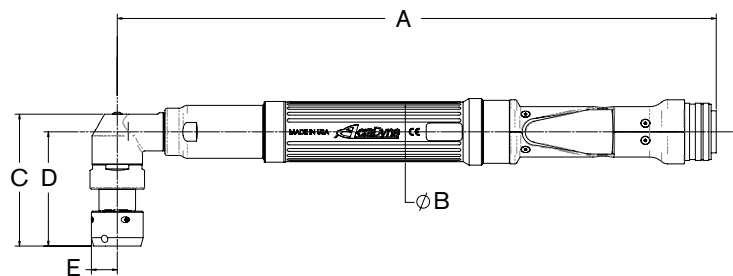

## DIMENSIONS\*

MODEL	IN	(A)	MM	IN	(B)	MM	IN	(C)*	MM	IN	(D)*	MM	IN	(E)	MM
AEH4F12020B	14.59		370.7	1.59		40.4	3.72		94.4	3.17		80.6	.76		19.3
AEH4F12026B	14.59		370.7	1.59		40.4	3.72		94.4	3.17		80.6	.76		9.3
AEH32025B	14.59		370.7	1.85		47	3.72		94.4	3.17		80.6	.76		19.3
AEH32030B	14.59		370.7	1.85		47	3.72		94.4	3.17		80.6	.76		19.3
AEH32040B	14.59		370.7	1.85		47	3.72		94.4	3.17		80.6	.76		19.3
AEH33053B	16.79		426.5	1.85		47	3.72		94.4	3.17		80.6	.76		19.3
AEH33060B	18.92		480.53	1.96		49.8	4.04		102.5	3.37		85.66	.94		23.9
AEH33090B	18.92		480.53	1.96		49.8	4.04		102.5	3.37		85.66	.94		23.9
AEH33120B	21.00		533.49	1.96		49.8	4.87		123.66	4.09		103.82	1.13		28.6
AEH33200B	23.21		589.5	1.96		49.8	4.87		123.66	4.09		103.82	1.13		28.6
AEH35140B	22.52		572.0	2.31		58.7	4.87		123.66	4.09		103.82	1.13		28.6
AEH35170B	22.52		572.0	2.31		58.7	4.87		123.66	4.09		103.82	1.13		28.6

# ACRADYNE® MID-EXIT CABLE NUTRUNNERS

## FEATURES AND BENEFITS

- **Length**
  - The tool's length is reduced by the cable exiting in front of the grip surface for the operator's hand.
- **Ergonomics**
  - Torque reaction is reduced relative to pistol style tools.
  - The hand is positioned farther away from the application for more leverage. This is maximized by the cable being in front of the hand. The handle is inline putting less stress on the wrist.
- **Cable management**
  - If used with a spring balancer the tool hangs naturally near its center of gravity and the cable can be controlled by the balancer.
  - The position of the cable in front can make it easier for the operator to manage the cable. This is especially beneficial where one plane has length constraints and at 90° is free from obstruction (vertical for Doors-On).



Specialized heads and blades available by request.

## APPLICATION DATA

MODEL*	NM	MAX TORQUE	FT-LB	NM	TORQUE RANGE	FT-LB	FREE SPEED RPM	LB	WEIGHT (-) SOCKET	KG	OUTPUT DRIVE
AEN4C22015BM(F)	15	11.06	11.06	3.75 - 15	2.77 - 11.06	700	2.6	1.18	3/8 SQ. DR.		
AEN4D22023BM(F)	23	16.96	16.96	5.75 - 23	4.24 - 16.96	750	2.9	1.32	3/8 SQ. DR.		
AEN4D22029BM(F)	29	21.39	21.39	7.25 - 29	5.35 - 21.39	592	2.9	1.32	3/8 SQ. DR.		
AEN4D22035BM(F)	35	25.81	25.81	8.75 - 35	6.45 - 25.81	480	2.9	1.32	3/8 SQ. DR.		
AEN4F22030BM(F)	30	22.13	22.13	7.5 - 30	5.53 - 22.13	675	3.3	1.50	3/8 SQ. DR.		
AEN4F22037BM(F)	37	29.29	29.29	9.25 - 37	6.82 - 29.29	533	3.3	1.50	3/8 SQ. DR.		
AEN4F22044BM(F)	44	32.46	32.46	11 - 40	8.11 - 29.50	432	3.3	1.50	3/8 SQ. DR.		
AES4A22020BM	20	14.8	14.8	5 - 20	3.7 - 14.8	1050	2.4	1.09	3/8 SQ. DR.		
AES4A22025BM	25	18.4	18.4	6.3 - 25	4.6 - 18.4	830	2.4	1.09	3/8 SQ. DR.		
AES4A22030BM	30	22.0	22.0	7.5 - 30	5.5 - 22.0	672	2.4	1.09	3/8 SQ. DR.		
AES4A22040BM	40	29.5	29.5	10 - 40	7.4 - 29.5	525	2.4	1.09	3/8 SQ. DR.		

\* Add "F" to part numbers for flush socket.

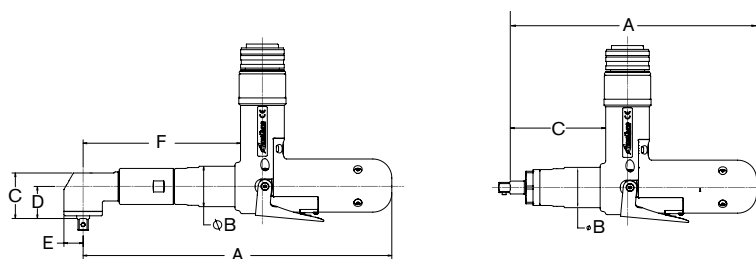

## DIMENSIONS

	IN (A)	MM	IN (B)	MM	IN (C)	MM	IN (D)	MM	IN (E)	MM	IN (F)	MM
AEN4C22015BM	9.02	229.1	1.47	37.3	1.29	32.8	.82	20.9	.52	13.1	5.53	140.4
AEN4D22023BM	11.1	280.3	1.47	37.3	1.42	36.1	.92	23.4	.56	14.1	5.67	144.1
AEN4D22029BM	11.1	280.3	1.47	37.3	1.42	36.1	.92	23.4	.56	14.1	5.67	144.1
AEN4D22035BM	11.1	280.3	1.47	37.3	1.42	36.1	.92	23.4	.56	14.1	5.67	144.1
AEN4F22030BM	11.24	285.6	1.47	37.3	1.66	42.1	1.17	29.7	.70	17.8	5.73	145.6
AEN4F22037BM	11.24	285.6	1.47	37.3	1.66	42.1	1.17	29.7	.70	17.8	5.73	145.6
AEN4F22044BM	11.24	285.6	1.47	37.3	1.66	42.1	1.17	29.7	.70	17.8	5.73	145.6
AES4A22020BM	9.0	228.1	1.47	37.3	3.49	88.6						
AES4A22025BM	9.0	228.1	1.47	37.3	3.49	88.6						
AES4A22030BM	9.0	228.1	1.47	37.3	3.49	88.6						
AES4A22040BM	9.0	228.1	1.47	37.3	3.49	88.6						



# ACRADYNE® RIV-NUT NUTRUNNERS

## FEATURES AND BENEFITS

- Top and Rear exit cable available standard.
- Straight, Fixtured and Push to Start models are available by request.



## APPLICATION DATA

MODEL*	NM	MAX TORQUE	FT-LB	NM	TORQUE RANGE	FT-LB	FREE SPEED RPM	LB	WEIGHT	KG	OUTPUT DRIVE
AEP4(A,R,T)12011BR	11		8.1	2.8 - 11		2 - 8.1	1,313	2.3	1.04		3/8 SQ. DR.
AEP4(A,R,T)12014BR	14		10.3	3.5 - 14		2.6 - 10.3	1,037	2.3	1.04		3/8 SQ. DR.
AEP4(A,R,T)12018BR	18		13.3	4.5 - 18		3.3 - 13.3	840	2.3	1.04		3/8 SQ. DR.
AEP4(A,R,T)12022BR	22		16.2	5.5 - 22		4.1 - 16.2	656	2.3	1.04		3/8 SQ. DR.
AEP4(A,R,T)22020BR	20		14.8	5 - 20		3.7 - 14.8	1,313	2.4	1.09		3/8 SQ. DR.
AEP4(A,R,T)22025BR	25		18.4	6.3 - 25		4.6 - 18.4	1,037	2.4	1.09		3/8 SQ. DR.
AEP4(A,R,T)22030BR	30		22.0	7.5 - 30		5.5 - 22.0	840	2.4	1.09		3/8 SQ. DR.
AEP4(A,R,T)22040BR	40		29.5	10 - 40		7.4 - 29.5	656	2.4	1.09		3/8 SQ. DR.

\* Add "A" to part numbers for bottom exit cable models, Add "R" to part numbers for rear exit cable models, Add "T" to part numbers for top exit cable models.

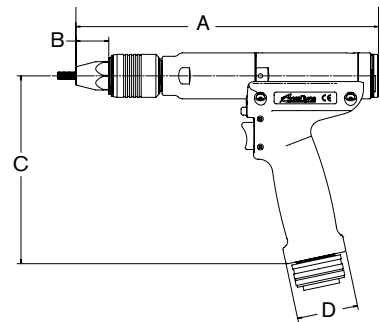

## DIMENSIONS

MODEL	IN	(A)	MM	IN	(B)	MM	IN	(C)*	MM	IN	(D)*	MM
AEP412011BR	9.68		245.9	1.05		26.7	6.87		174.5	1.96		49.8
AEP412014BR	9.68		245.9	1.05		26.7	6.87		174.5	1.96		49.8
AEP412018BR	9.68		245.9	1.05		26.7	6.87		174.5	1.96		49.8
AEP412022BR	9.68		245.9	1.05		26.7	6.87		174.5	1.96		49.8
AEP422020BR	10.18		258.6	1.05		26.7	6.87		174.5	1.96		49.8
AEP422025BR	10.18		258.6	1.05		26.7	6.87		174.5	1.96		49.8
AEP422030BR	10.18		258.6	1.05		26.7	6.87		174.5	1.96		49.8
AEP422040BR	10.18		258.6	1.05		26.7	6.87		174.5	1.96		49.8

# ACRADYNE® HIGH TORQUE TOOLS

## FEATURES AND BENEFITS

Critical high torque assembly applications demand tools that will deliver torque with superior performance and durability. The precision design of the HT Series from AcraDyne® combine these features in an electric tool that surpasses the competition on productivity and ergonomics. AcraDyne's transducer torque control system provides consistent, reliable torque values as well as the ability to monitor rotational angle during the tightening process. When combined with AcraDyne's Tool Controllers, customers have a high torque assembly system that can handle the toughest and most important critical bolting applications with the ease and accuracy they demand.

- Faster Free Speed – Up to three times faster than the competition.
- Accurate built-in transducer ensures that torque values are accurate. No “guesstimates”.
- Closed Loop Torque Control System.
- Interchangeable Tools, Cables and Controllers – Calibrations are specific to the tool not the system as a whole.
- Universal Controller for all AcraDyne® tools.
- On-tool LED's for Accept / Reject signals.
- Designed and **MADE IN THE USA.**



FIXTURED TYPE (AEF)



REAR MOUNTED PISTOL (AED)



STRAIGHT LEVER TYPE (AES)



AXIAL TYPE (AEJ)

MODEL* (handle type)	SERIES	APPROX. TORQUE		APPROX. SPEED	WEIGHT		LENGTH		DIA.		DRIVE in	SOUND LEVEL dB(A)
		Nm	ft-lb	rpm	kg	lb	mm	in	mm	in		
( )4(A)(B)66500A	6000	500	370	120	5.7	12.5	300	11.8	66	2.6	0.75	66
( )4(A)(B)66750A	6000	750	550	85	5.7	12.5	300	11.8	66	2.6	0.75	66
( )4(A)(B)771000A(B)	7000	1,000	750	65	5.7	15	300	11.8	66	3.0	1	66
( )4(A)(B)772500A(B)	7000	2,500	1,850	25	8.1	17	328	12.9	76	3.0	1	66
( )4(A)(B)883000A1	8000	3,000	2,200	20	12.3	27	376	14.8	86	3.6	1	66
( )4(A)(B)883000A	8000	3,000	2,200	20	12.3	27	376	14.8	86	3.6	1.5	66
( )4(A)(B)884100A1	8000	4,650	3,400	12	12.3	27	376	14.8	86	3.6	1	66
( )4(A)(B)884100A	8000	4,650	3,400	12	12.3	27	376	14.8	86	3.6	1.5	66
( )4(A)(B)896500A	9000	6,500	4,800	7	15	33	457	18	101	4.0	1.5	66
( )4(A)(B)898100A**	9000	8,100	6,000	5	15	33	457	18	101	4.0	1.5	66

\*Add "A" to part numbers for fixed gearcase models. Add "B" to part numbers for clutched gearcase models. For fixtured type, add "B" to part numbers for bottom exit cable.

\*\*Under development

# ACRADYNE® HT RIGHT ANGLE AND GEARHEAD TOOLS

## FEATURES AND BENEFITS

- Custom made to fit virtually any application.
- Same high durability gearing as on AcraDyne's standard HT Series of tools.
- Model types available:
  - HT Right Angle tools
  - HT Offset Gearhead tools
  - HT Right Angle with Offset Head
- Torque ranges from 400Nm to 4650Nm.
- Right angle air tools to 2500Nm also available.



# ACRADYNE® HIGH TORQUE TOOLS

## CABLES

Newly designed cable and connectors for excellent ergonomics, maximum-quality signal transfer and full CE compliance.

MODEL	LENGTH
24330	3 meter
25350	5 meter
24320	10 meter
27110	3 meter, lightweight
27115	5 meter, lightweight
27112	10 meter, lightweight



## BREAKAWAY CABLE CONNECTOR

Ensures disconnect of cable should stress in excess of 40 lbs occur.



## REACTION BARS

Each tool includes a standard spline-attachment reaction device. Custom reaction devices are also available; contact your AIMCO sales representative for more details, 1-800-852-1368.

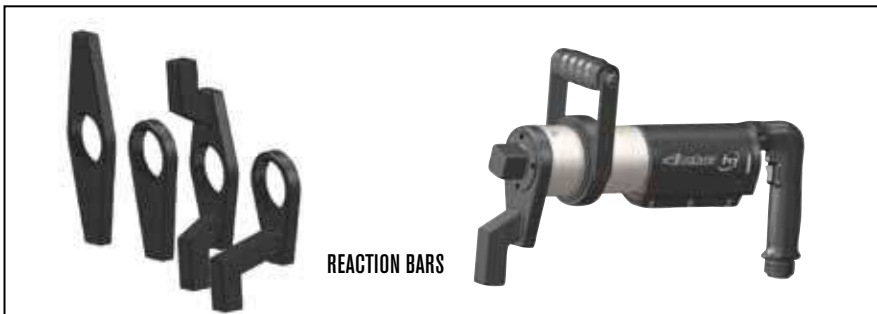

MODEL	DESCRIPTION
26810	Single Ended, Flat, 6000 Series
26815	Single Ended, Standard Offset, 6000 Series
26830	Double Ended, Flat, 6000 Series
26835	Double Ended, Standard Offset, 6000 Series
26800	Single Ended, Flat, 7000 Series
26805	Single Ended, Standard Offset, 7000 Series
26820	Double Ended, Flat, 7000 Series
26825	Double Ended, Standard Offset, 7000 Series
25277	Single Ended, flat, 8000 Series
25274	Single Ended, 3.35" offset, 8000 Series
25275	Single Ended, 4.00" offset, 8000 Series
25278	Double Ended, flat, 8000 Series
25276	Double Ended, 3.35" offset, 8000 Series
27255	Single Ended, flat, 9000 Series
26840	Single Ended, 3.35" offset, 9000 Series

## ACCESSORIES

Custom accessories are also available for your application; contact your AIMCO sales representative for more details, 1-800-852-1368.



MODEL	DESCRIPTION
26477	Swivel Bail Assembly, 6000 Series
26478	Swivel "D" Handle Assembly, 6000 Series
26479	Stationary Bail Assembly, 6000 Series
26337	Rear Fixed Hoist Ring Sub-Assembly, 6000 Series
26327	Swivel Bail Assembly, 7000 Series
26328	Swivel "D" Handle Assembly, 7000 Series
26336	Fixed Handle Sub-Assembly, 7000 Series
26337	Rear Fixed Hoist Ring Sub-Assembly, 7000 Series
25291	Swivel Handle, 8000 Series
25287	Swivel Bail Hoist, 8000 Series
25497	Rear fixed hoist ring, 8000 Series
25289	Fixed hoist (handle not included), 8000 Series
25280	Auxiliary Handle, 8000 Series
26822	Mounting Flange, 7000 Series
27045	Sliding Spindle, 7000 Series

# DC TOOLS: TOOL/SPINDLE SELECTION GUIDE

MODEL	RPM	LENGTH		WEIGHT		TORQUE, Nm																			
		in	mm	lb	kg	5	10	15	20	25	50	75	100	125	150	175	200	225	250	275	300	325	350	375	400
<b>ANGLE</b>																									
AEN4B12004B	3,111	11.65	295.9	2.0	0.91																				
AEN4C12009B	1,750	11.00	279.5	2.2	0.91																				
AEN4C12014B	875	11.66	296.4	2.2	1.00																				
AEN4C12018B	691	11.66	296.4	2.2	1.00																				
AEN4C12022B	560	11.66	296.4	2.2	1.00																				
AEN32015B	1481	14.8	376.7	2.7	1.22																				
AEN32025B	833	14.8	376.7	2.7	1.22																				
AEN32030B	803	14.6	371.9	2.8	1.27																				
AEN32040B	574	14.6	371.9	2.8	1.27																				
AEN33042B	1,095	16.6	422.3	4.4	2.00																				
AEN33053B	1,095	16.6	422.3	4.4	2.00																				
AEN33060B	845	19.1	485.7	6.6	2.99																				
AEN33090B	568	19.1	485.7	6.6	2.99																				
AEN33120B	442	21.2	539.0	9.3	4.22																				
AEN33200B	245	23.4	594.4	9.4	4.26																				
AEN33300B	151	23.8	603.8	10.0	4.54																				
AEN35090B	607	22.6	573.7	6.9	3.13																				
AEN35140B	472	22.5	571.9	10.4	4.72																				
AEN35175B	384	22.5	571.9	10.5	4.76																				
AEN35225B	291	22.9	581.1	12.3	5.58																				
AEN35285B	236	22.9	581.1	12.3	5.58																				
AEN35350B	191	22.9	581.1	12.3	5.58																				
<b>INLINE</b>																									
AES4A12003B_	2,625	11.12	282.7	2.0	0.91																				
AES4A12006B_	2,625	11.12	282.7	2.0	0.91																				
AES4A12011BV	1,313	11.44	290.5	2.2	1.00																				
AES4A12014BV	1,037	11.44	290.5	2.2	1.00																				
AES4A12018BV	840	11.44	290.5	2.2	1.00																				
AES4A12022BV	656	11.44	290.5	2.2	1.00																				
AES32010B_	2222	14.3	363.7	2.5	1.13																				
AES32020B_	1250	14.3	363.7	2.5	1.13																				
AES32025B_	893	14.3	363.7	3.2	1.45																				
AES32038BV	595	17.2	435.9	4.2	1.91																				
AES33040BV	1314	18.7	475.7	6.4	2.90																				
AES33060BV	883	18.7	475.7	6.4	2.90																				
AES33100BV	489	23.1	585.7	8.1	3.67																				
AES33150BV	329	23.1	585.7	8.1	3.67																				
AES33230BV	221	23.1	585.7	8.1	3.67																				
AES33400BV	122	25.5	647.7	13.0*	5.90*																				
AES33600BV**	82	25.5	647.7	13.0*	5.90*																				
AES35075BV	944	21.9	555.2	9.2	4.17																				
AES35090BV	767	21.9	555.2	9.2	4.17																				
AES35110BV	634	21.9	555.2	9.2	4.17																				
AES35135BV	515	21.9	555.2	9.2	4.17																				
AES35170BV	418	21.9	555.2	9.2	4.17																				
AES35280B	236	24.2	615.1	12.8	5.81																				
AES35350B	192	24.2	615.1	12.8	5.81																				
AES35420B	159	24.2	615.1	12.8	5.81																				
AES35515B***	129	24.2	615.1	12.8	5.81																				
AES35635B****	104	24.2	615.1	12.8	5.81																				

\*Including reaction bar and fixture nut.

\*\*Torque Range: 120-480 Nm Max Torque: 600 Nm

\*\*\* Torque Range: 128-515 Nm \*\*\*\*Torque Range: 159-635 Nm

Recommended Torque Range

Max Torque



# ACRADYNE® ACCESSORIES

## CABLE ASSEMBLIES

The AcraDyne® DC electric nutrunner tool system uses a single cable to carry all necessary conductors for superior ergonomics and durability.

- Flexible polyurethane cover for maximum durability, abrasion and transmission fluid resistant.
- Quick disconnects at both ends facilitate tool changeover and troubleshooting.
- The CAN data/signal is via RJ45 for products such as the KDM, socket tray or computer.

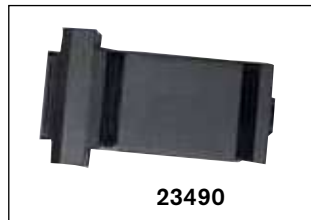
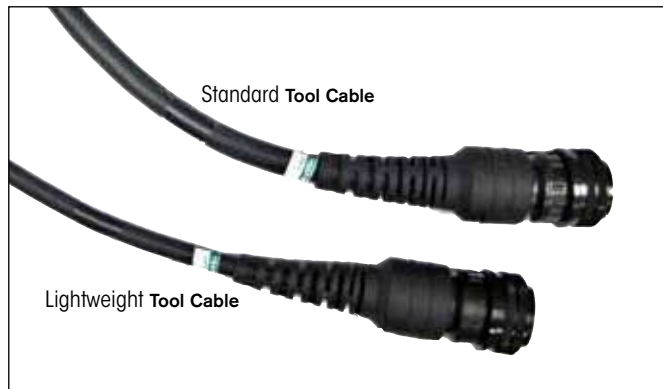

MODEL	DESCRIPTION	LENGTH	
		m	ft
<b>TOOL CABLES</b>			
24330	Cable G3 Tool Cable 3M	3	9.8
25350	Cable G3 Tool Cable 5M	5	16.4
24320	Cable G3 Tool Cable 10M	10	32.8
27110	Cable G3 Tool Cable 3M Lightweight	3	9.8
27115	Cable G3 Tool Cable 5M Lightweight	5	16.4
27122	Cable G3 Tool Cable 10M Lightweight	10	32.8
25646	G1 iEC to G3 Cable Adapter		
26934	G3 iEC to G1 Cable Adapter		
27210	G3 Tool to G1 Cable Adapter		
26364	Right Angle Cable Adapter		
26709	G3 Tool to G1 Cable (Cable Tester only)		
26700	Cable Tester Unit, G3		
26594	Conversion Kit G1 iEC to G3 iEC		
27370	Conversion Kit G3 iEC to G1 iEC		
25491	Breakaway Cable Connector – Ensures disconnect of cable should stress in excess of 40 lbs occur		
<b>EXTENSION</b>			
24320	Extension cable 10M	10	32.8
25518	Extension cable 20M	20	65.6
<b>DATA</b>			
20403	Data/signal connection cable – Accessories to controller	2.0	6
23490	I/O Wiring Connector – Simple Module to facilitate connections to I/O on IEC Controllers		
AEC-CIM	Interface module which allows communication between a computer and an AcraDyne® controller through USB or CAN connections. All necessary cables included.		

## KEYPAD DISPLAY MODULE (KDM)

- For tool setup, statistical display, and basic diagnostics, can be built-in, handheld, or remotely mounted.
- For remote mounting. Connects to AcraDyne® controllers via 20403 data cable (Can only be used by connection to a controller).



## SOCKET TRAY

- Simply remove the assigned socket to select the application to be run.
- Quick and easy set up. Parameters assigned to socket position automatically.
- Optional self illuminating socket receptacles.
- Delrin® blanks may be easily machined by the customer to accommodate custom socket profiling.
- Nothing to break, wear out or maintain.
- Proximity sensors detect presence of socket.
- Can also be used with UEC style controllers.

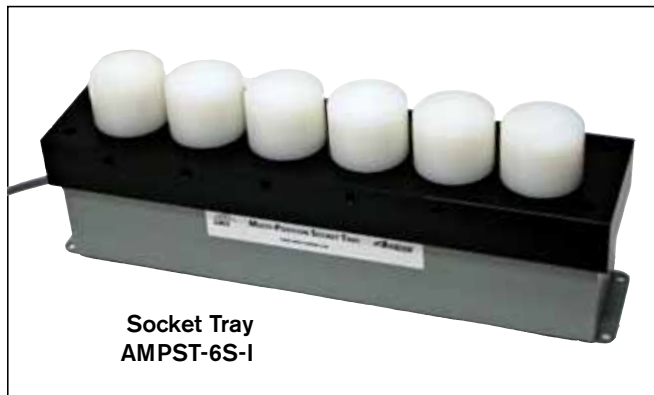

MODEL	DESCRIPTION
AMPST-2-I	2 Position Socket Tray for iEC Controllers
AMPST-4-I	4 Position Socket Tray for iEC Controllers
AMPST-6S-I	6 Position Socket Tray for iEC Controllers, Straight Line
AMPST-6-I	6 Position Socket Tray for iEC Controllers
AMPST-8-I	8 Position Socket Tray for iEC Controllers

## TOOL BAILS

- AcraDyne's spring bails are designed for use with any of the AcraDyne® 1000, 2000 or 3000 Series tools.
- The spring bails snap on quickly and firmly at any place on the body of the tool for perfect balance and secure suspension.



MODEL	DESCRIPTION
25501	Wire Bail for 1000-Series Tools
26568	Cable Bail to Hang Tool Vertically for GenIII Cables
21159	2000/3000 Vertical Tool Hanger for Gen1 Tools
21208	Spring Bail for 2000-Series Tools
23662	Rotating Bail for 2000-Series Tools
23575	Rotating Bail for 3000-Series Tools

## UNIVERSAL TOOL BASKET



## SLIDING SPINDLES



MODEL	DESCRIPTION
20712	Sliding Spindle 2" Stroke 2000 Series Tools
20848	Sliding Spindle 2" Stroke 3000 Series Tools



# ACRADYNE® ACCESSORIES

## TORQUE TUBES

- Made to order Torque Tubes to suit the specific application.
- Counteract torque reactive forces.
- Suspend from a variety of options.
- Pneumatic Counter Balance with high resolution adjustments.
- Quick and easy quotation process.

### Support Mounting Options



Double Clevis

Single Clevis

Flat Clevis

### Tool Mounting Options



Square Plate

Vertical Tool

Horizontal Tool

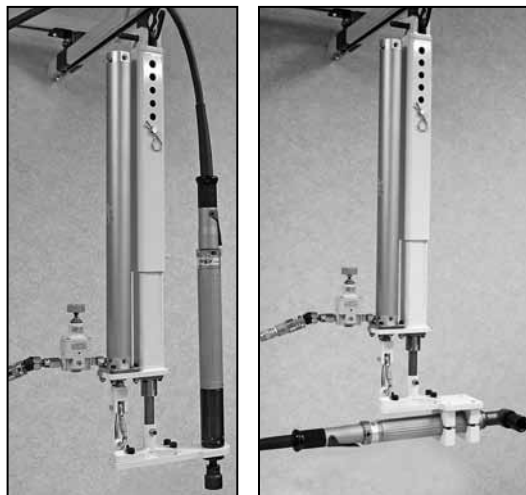

## CARBON ARMS

- With the Carbon Torque Arm, the assembly operation will be smooth and comfortable since the arm is absorbing the torque reaction generated by the tool.
- The Carbon Arm is ergonomic and easy to use due to the telescopic design that allows maximum movement and flexibility.
- Extremely durable and requires no maintenance.

MODEL	DESCRIPTION
CLR55-1230	55Nm, Max Length 1230 mm
CLR55-2000	55Nm, Max Length 1800 mm
CLR55-2500	55 Nm, Max Length 2430 mm
CLR100-1230	100 Nm, Max Length 1230 mm
CLR100-2000	100 Nm, Max Length 1800 mm
CLR100-2500	100 Nm, Max Length 2430 mm
CLR150-1230	150 Nm, Max Length 1230 mm
CLR150-2000	150 Nm, Max Length 1800 mm
CLR150-2500	150 Nm, Max Length 2430 mm
CLR220-1230	220 Nm, Max Length 1230 mm
CLR220-2000	220 Nm, Max Length 1800 mm
CLR220-2500	220 Nm, Max Length 2430 mms

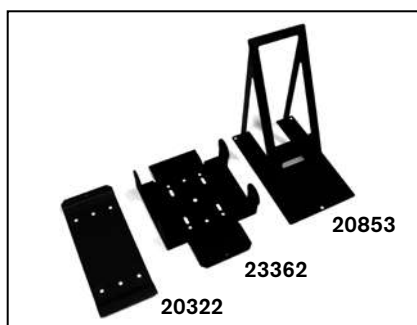

## CONTROLLER BRACKETS

MODEL	DESCRIPTION
20322	Wall Plate Bolts to wall allows controller bracket (23362) to hang without hard fastening
23362	Controller Bracket Included with all iEC and iControl AcraDyne Controllers. Bolts to wall or hang of optional Wall Plate (20322)
20853	Table Stand Free standing platform enables Controller Bracket (23362) to simply hang from.

## MOUNTING BRACKETS

MODEL	DESCRIPTION
25717	Mounting Bracket for 1000-Series Angle Tools
25843	Mounting Bracket for 1000-Series Push-To-Start Tools
26443	Mounting Bracket for Straight and Pistol 1000/2000-Series
24924	Mounting Flange for Straight and Pistol 1000/2000-Series
25718	Mounting Bracket for 3000/5000-Series Angle Tools
26570	Mounting Bracket for 3000/5000-Series Straight Tools
25265	Anglehead Mounting Bracket (Cradle type) for 3000/5000 Angle Tools over 225Nm



## TOOL BODY JACKETS

Keep your tools protected and avoid accidental damage to the application with AIMCO's tool body jackets.

MODEL	DESCRIPTION
BJ10051	For 1000 series angle tools
BJ10052	For 2015, 2025 series angle tools
BJ10053	For 2030, 2040, 2055 series angle tools
BJ10054	For 3060, 3090 series angle tools
BJ10055	For 3120, 3200 series angle tools

## BARCODE READER



MODEL	DESCRIPTION
LS4208	RS232 Barcode Reader Kit
LS4278	RS232 Wireless Barcode Reader Kit

## LIGHT TOWER

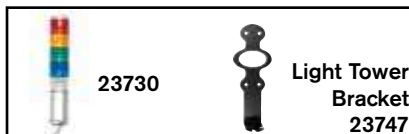

23730

Light Tower Bracket  
23747



## MULTIPLE NUTRUNNING SYSTEMS

AIMCO is able to integrate the AcraDyne® tool spindle into a customized Multiple Nutrunning System. From simple systems vertically suspended above the part to assembly stations that integrate with your line, AIMCO can handle your project.

**LET US KNOW YOUR REQUIREMENTS AND WE WILL PROPOSE A SOLUTION TAILORED TO YOUR NEEDS.**



## SMALL ENGINE MANUFACTURER

- Air cooled small vehicle engine assembly.
- Ten spindle 2.4–2.8 kgf-m
- Integrated PLC control of system functions.
- Supplied overhead rail follows line and returns powerhead to home position.
- Powerhead features single lever control and visual confirmation of accepted torque.

## FEATURES AND BENEFITS

- Nutrunner sequencing - Allows nutrunners to be sequenced at each phase of the tightening process providing even distribution of torque and load to each fastener.
- Even torque distribution - Where there is uneven torque distribution, part damage or distortion could occur with possible fastener failure or loss of residual clamp load.
- Snug, threshold, final torque in one pass - No need for multiple torque stage sequencing. Fixtured nutrunners save time and effort.
- No missed fasteners - With multiple nutrunners there is a spindle dedicated to each location, ensuring quality on every rundown on every bolt.
- Better residual torques - Synchronized controlled fastening allows residual torque levels to be consistent with the dynamic torque specification.
- Saving in cycle time - Compared to using a single nutrunner tool with many rundowns, running all fasteners simultaneously reduces in-station cycle time.
- Cost saving benefits - Saving installation cycle time frees operators to handle additional tasks and potentially reduce labor costs.
- Collect data - Most common methods of collecting data for quality control and statistical analysis can be implemented from a serial data string using RS232 to formatted data from a network database.

## ENGINE MANUFACTURER

- Gasoline generator assembly.
- Six spindle 30 Nm
- Replaced hand assembly with rotation pattern to simultaneous rundown.

## AUTOMOTIVE MANUFACTURER

- Wheel lug nut assembly.
- Four spindle 105 Nm
- Rotating spindle trunnion.
- Replaced competitive system.
- Built-in PC for data storage.
- Custom display panel showing application.
- Cpk range of 3.2–6.9 far exceed quality requirements.



# FIXTURED F-SERIES NUTRUNNERS

## FEATURES AND BENEFITS



- Reduced Cable Numbers – Integral type tube containing torque sensor cable and resolver cable.
- Enhanced Memory Capacity – Designed with increased memory capacity for improved efficiency of assembly line and tightening data control.
- Open Network Communication – We have prepared various types of communication boards for your specifications (M-NET, Device net, Inter-bas, CC-link).
- Automatic Setting (Automatic recommended value input) – Advance value preparation per application will help you simplify your parameter setting.
- Space Saving – One piece structure contained spindle controller and driver unit reduces space occupancy by 40% to 60% .

NO. OF SPINDLES	VOLUME & WIDTH BEFORE		VOLUME & WIDTH WITH F-SERIES			
	cm	mm	UEC-F024		UEC-F120	
1-Spindle	16,800	200	6,360	150	8,268	195
2-Spindle	24,360	290	8,904	210	12,084	285
5-Spindle	47,040	560	16,536	390	24,804	585
10-Spindle	84,840	1,010	29,256	690	48,336	1,140

## F-SERIES NETWORK CONNECTIVITY

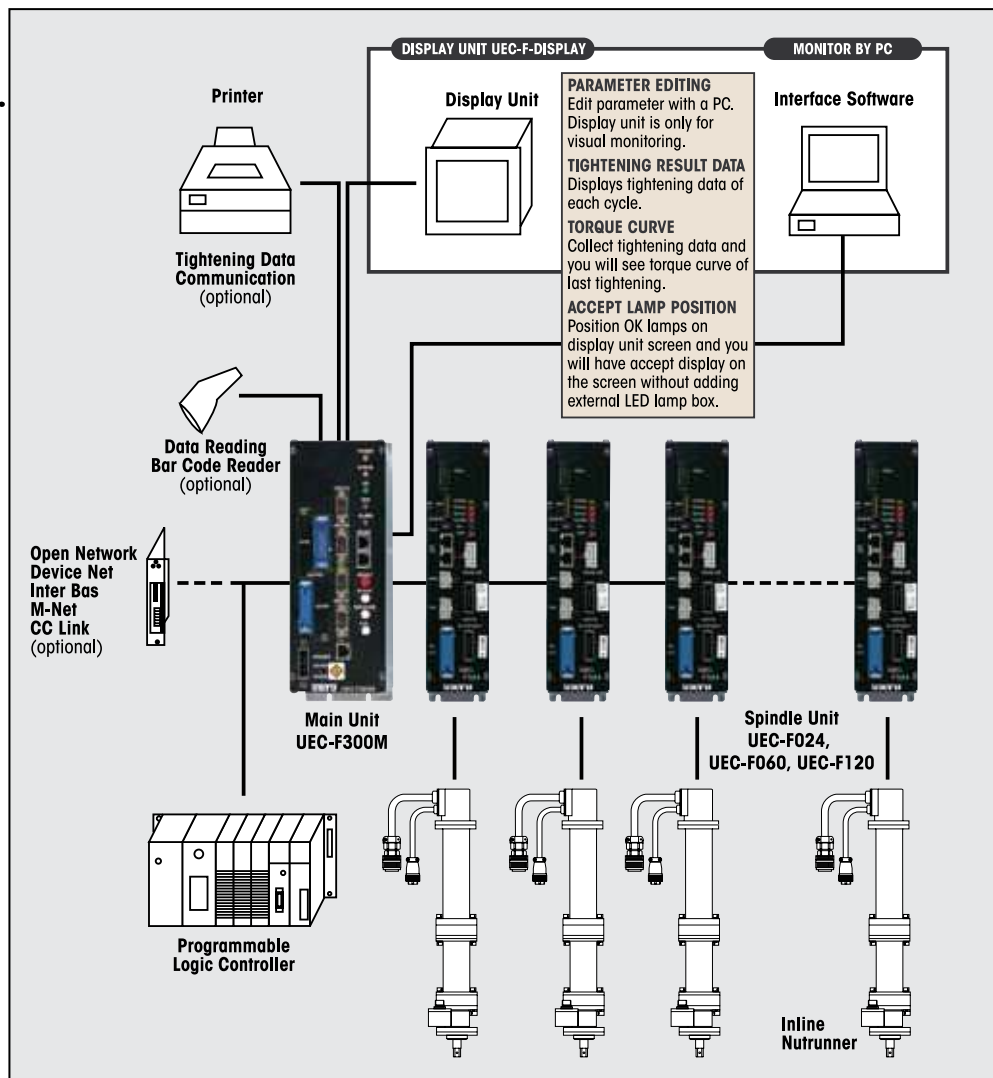

# FIXTURED F-SERIES NUTRUNNERS

Main unit UEC-F300M

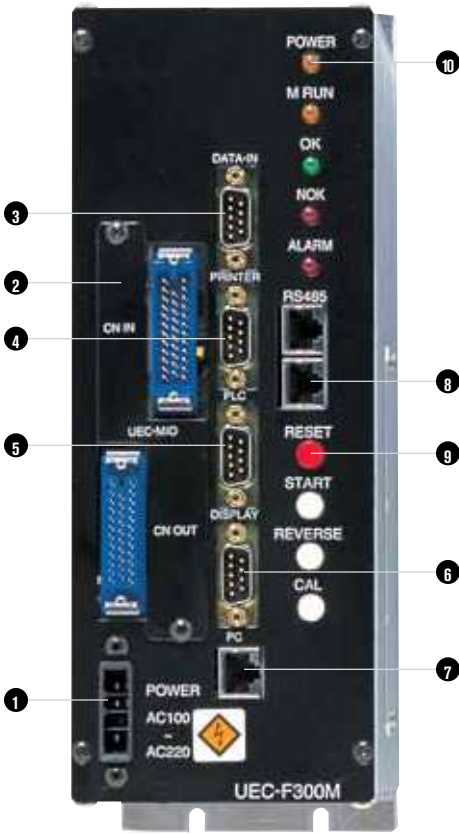

Spindle unit UEC-F024

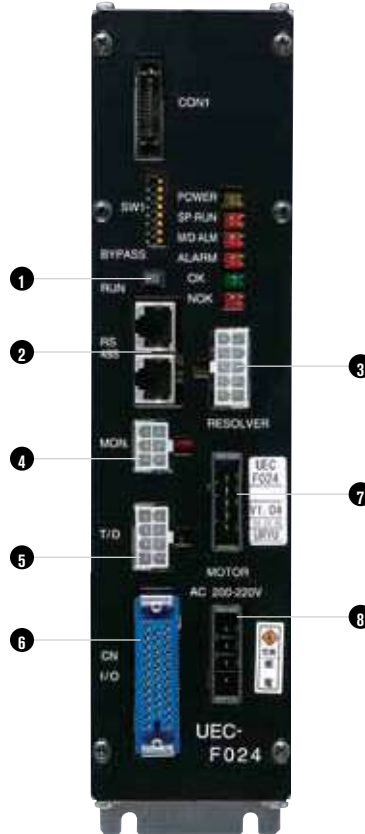

UEC-MKB



- 1 Power Socket**  
AC100~220V single phase
- 2 External Input/Output Connector**  
PLC1: input signal connector for control signal input (fixed allocation)  
PLC2: output signal connector for judgement result and status output (free allocation)
- 3 Serial Port (Data Input Connector)**  
RS232C DATA-IN accepts serial numbers, etc. provided by external equipment such as a barcode reader then outputs tightening data together with serial numbers.
- 4 Serial Port (Data Output Connector)**  
RSC232C PRINTER outputs tightening result data to your printer (free format)
- 5 Serial Port (Data Output Connector)**  
RSC232C PLC outputs tightening result data to PLC (free format)
- 6 Serial Port (Data Output Connector)**  
RS485 outputs tightening result data to an external exclusive display unit
- 7 PC Connector**  
RSC232C for communication with a PC
- 8 Spindle-to-Spindle Communication Connector**  
RS485 for internal spindle unit to spindle unit communications
- 9 Manual Switches**  
RESET, START, REVERSE and CAL
- 10 LED Display**  
POWER, M RUN, ACCEPT, REJECT and ALARM

- 1 Status Change Switch**  
RUN/BYPASS change switch  
RUN: Operation possible status  
BYPASS: Non-operation status
- 2 External Communication Device**  
RS485 connector
- 3 Resolver Connector**  
Tool and resolver connection
- 4 MON Connector (Monitor Output)**  
Analog torque electric pressure and angle pulse output
- 5 T/D Connector**  
Tools torque sensor connection
- 6 I/O Connector**  
External input and output control connection
- 7 MOTOR Connector**  
Connection with tools magnet motor
- 8 AC IN Connector**  
AC200V~220V 3-phase power socket

- 1 Manual Operation Switches**  
START: manual start switch  
REVERSE: Manual reverse switch  
CAL: Manual calibration switch  
RESET: Manual reset switch
  - 2 Data Display Operation Switch**  
MODE switch  
SET switch  
DATA UP switch  
DATA DOWN switch
- NOTE: Display unit (UEC-MKB) is an option.

**The "F" Series Nutrunner System will satisfy multiple tightening patterns.**

- Torque Tightening
- Spline Press Ft Tightening
- Torque
- Pin Hole Alignment Tightening
- Angle Tightening
- Pre-Load Detection
- Angle
- Idle Operation Check
- Plastic Range Monitor

# FIXTURED F-SERIES NUTRUNNERS

## INLINE NUTRUNNERS

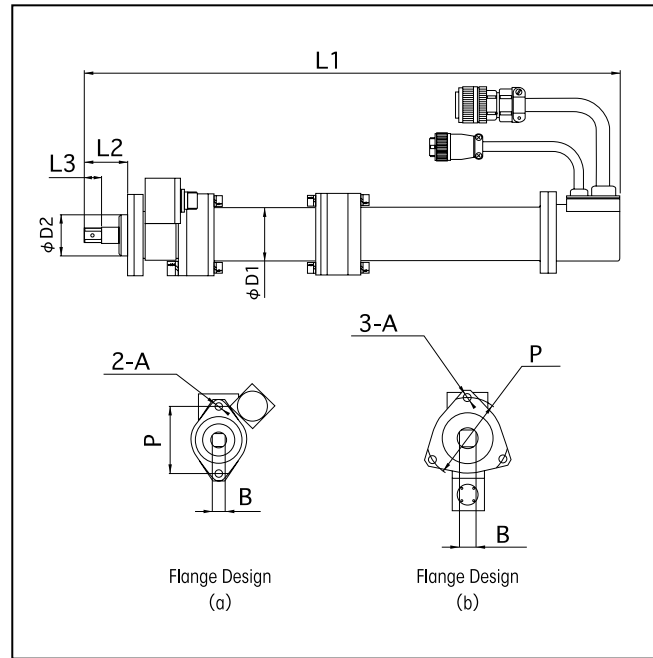

## APPLICATION DATA

TYPE	EXTERNAL DIMENSIONS (mm)								TORQUE SENSOR	MOTOR TYPE	FLANGE DESIGN
	L1	L2	L3	D1	D2	P	A	B			
UNR-F015-45NT	371	41	12	40.5	38	51	M6	9.5	TM-035	F015	(a)
UNR-F015-65NT	371	41	12	40.5	38	51	M6	9.5	TM-035	F015	(a)
UNR-F015-200NT	400	41	12	40.5	38	51	M6	9.5	TM-035	F015	(a)
UNR-F015-280NT	400	41	12	40.5	38	51	M6	9.5	TM-035	F015	(a)
UNR-F015-350NT	400	41	12	40.5	38	51	M6	9.5	TM-035	F015	(a)
UNR-F050-270NT	453.5	41	12	50	38	51	M6	9.5	TM-035	F050	(a)
UNR-F050-630NT	500.5	41	16.5	50	38	62	M8	12.7	TM-085	F050	(a)
UNR-F050-730NT	500.5	41	16.5	50	38	62	M8	12.7	TM-085	F050	(a)
UNR-F050-880NT	512.5	45	20	50	48	62	M8	15.88	TM-150	F050	(a)
UNR-F050-1400NT	512.5	45	20	50	48	62	M8	15.88	TM-150	F050	(a)
UNR-F100-1300NT	519.5	45	20	62	48	62	M8	15.88	TM-150	F100	(a)
UNR-F100-1900NT	515.5	45	20	62	48	76	M8	15.88	TM-250	F100	(b)
UNR-F100-2500NT	515.5	45	20	62	48	76	M8	15.88	TM-250	F100	(b)
UNR-F100-3700NT	589	57	30	62	58	76	M10	19	TM-400	F100	(b)
UNR-F100-5400NT	704.5	80	40	62	70	90	M10	25.4	TM-700	F100	(b)

## Torque Sensor Specifications

TYPE	CAPACITY (Nm)
TM-035	34.3
TM-085	83.3
TM-150	147
TM-250	245
TM-400	392
TM-700	686
TM-1000	980

Rated Strain	2000X10-6
Output Voltage	1.0mV/V
Non-Linearity	±0.5% R.O.
Influence on Zero Point Due to Temperature	±0.1% R.O./°C
Temperature Rating	-10 ~ +65°C
Input Output Resistance	480Ω
Maximum Input Voltage	16V
Insulation Resistance	Greater than 300Ω
Overload Capacity	150%

## INLINE MOTOR SPECIFICATIONS

TYPE	TIGHTENING TORQUE (Nm)	FREE SPEED (rpm)	WEIGHT (kg)	SPINDLE UNIT
UNR-F015-45NT	4.5	3,200	2.48	UEC-F024
UNR-F015-65NT	6.5	2,200	2.48	UEC-F024
UNR-F015-200NT	20	730	2.73	UEC-F024
UNR-F015-280NT	28	500	2.73	UEC-F024
UNR-F015-350NT	35	410	2.73	UEC-F024
UNR-F050-270NT	27	1,750	4.86	UEC-F060
UNR-F050-630NT	63	750	5.08	UEC-F060
UNR-F050-730NT	73	650	5.08	UEC-F060

TYPE	TIGHTENING TORQUE (Nm)	FREE SPEED (rpm)	WEIGHT (kg)	SPINDLE UNIT
UNR-F050-880NT	88	540	5.47	UEC-F060
UNR-F050-1400NT	140	340	5.47	UEC-F060
UNR-F100-1300NT	130	730	7.42	UEC-F120
UNR-F100-1900NT	190	500	7.94	UEC-F120
UNR-F100-2500NT	250	370	7.94	UEC-F120
UNR-F100-3700NT	370	260	9.55	UEC-F120
UNR-F100-5400NT	540	175	17.0	UEC-F120

# FIXTURED F-SERIES NUTRUNNERS

## “F” NUTRUNNER MOTORS’ MINIMUM PITCH CIRCLE

Refer to minimum pitch circles for designing your machine.

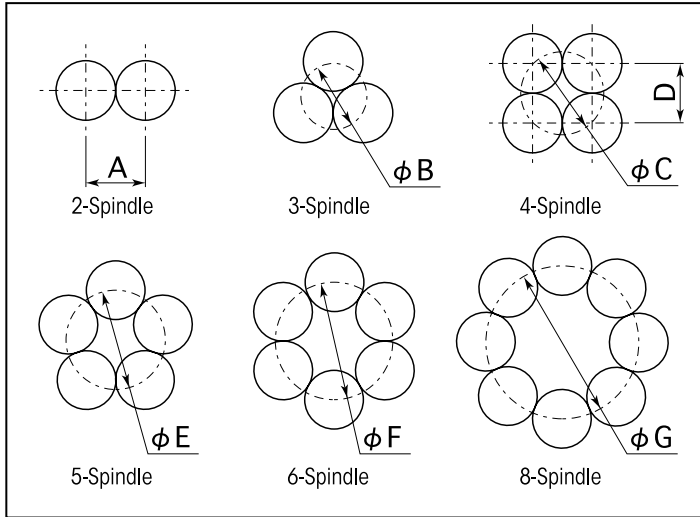

TYPE	DIMENSIONS (mm)						
	A	B	C	D	E	F	G
UNR-F015-45NT	43	52	64	46	74	92	122
UNR-F015-65NT	43	52	64	46	74	92	122
UNR-F015-200NT	43	52	64	46	74	92	122
UNR-F015-280NT	43	52	64	46	74	92	122
UNR-F015-350NT	43	52	64	46	74	92	122
UNR-F050-270NT	59	72	90	64	108	122	160
UNR-F050-630NT	59	72	90	64	108	122	160
UNR-F050-730NT	59	72	90	64	108	122	160
UNR-F050-880NT	59	72	90	64	108	122	160
UNR-F050-1400NT	59	72	90	64	108	122	160
UNR-F100-1300NT	66	75	92	65	116	130	170
UNR-F100-1900NT	70	100	110	78	115	132	174
UNR-F100-2500NT	70	100	110	78	115	132	174
UNR-F100-3700NT	76	100	110	78	120	140	184
UNR-F100-5400NT	94	125	143	102	166	188	257
UNR-F100-7000NT	94	125	143	102	166	188	257
UNR-F100-10000NT	94	125	143	102	166	188	257

## RIGHT ANGLE NUTRUNNERS

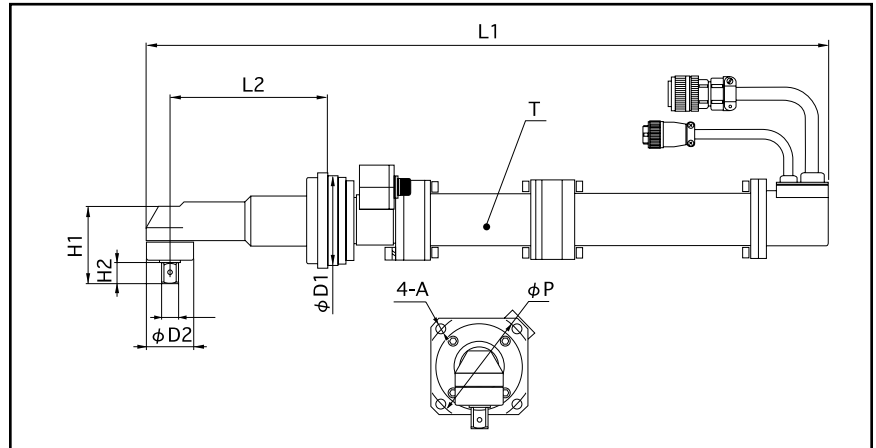

TYPE	EXTERNAL DIMENSIONS (mm)										STRAIGHT MOTORS		
	L1	L2	H1	H2	D1	D2	P	A	B	TYPE	SENSOR	MOTOR	
UNR-F015-25NTC	507	120	49	10.6	70	28	85	M6	9.5	UNR-F015-200NT	TM-035	F015	
UNR-F015-55NTC	521	130	58	18	70	36	85	M6	12.7	UNR-F015-350NT	TM-035	F015	
UNR-F050-95NTC	643	150	73.5	20	85	45	102	M6	15.88	UNR-F050-630NT	TM-085	F050	
UNR-F050-130NTC	649	150	73.5	20	85	45	102	M6	15.88	UNR-F050-880NT	TM-150	F050	
UNR-F100-200NTC	681.5	170	85.5	20	85	56	102	M6	15.88	UNR-F100-1300NT	TM-150	F100	
UNR-F100-250NTC	677.5	170	85.5	20	100	56	120	M8	15.88	UNR-F100-1900NT	TTM-150	F100	
UNR-F100-380NTC	716.5	200	109.5	25	110	74	134	M10	19	UNR-F100-2500NT	TM-250	F100	
UNR-F100-550NTC	784	200	114.5	29	110	74	134	M10	25.4	UNR-F100-3700NT	TM-400	F100	

## RIGHT ANGLE MOTOR SPECIFICATIONS

TYPE	TIGHTENING TORQUE (Nm)	FREE SPEED (rpm)	WEIGHT (kg)	SPINDLE UNIT
UNR-F015-25NTC	25	460	4.18	UEC-F024
UNR-F015-55NTC	55	260	4.37	UEC-F024
UNR-F050-95NTC	95	480	8.08	UEC-F060
UNR-F050-130NTC	130	340	8.3	UEC-F060

TYPE	TIGHTENING TORQUE (Nm)	FREE SPEED (rpm)	WEIGHT (kg)	SPINDLE UNIT
UNR-F100-200NTC	200	460	11.92	UEC-F120
UNR-F100-250NTC	250	340	12.3	UEC-F120
UNR-F100-380NTC	380	235	15.92	UEC-F120
UNR-F100-550NTC	550	165	17.43	UEC-F120

# UEC-4800 CONTROLLER

## STATE-OF-THE-ART CONTROLLER FOR PULSE AND CONTINUOUS DRIVE TOOLS

### FEATURES AND BENEFITS: UEC-4800

- Programmable from front panel or PC – no separate touchpad module or cable required.
- 12,000 data point memory.
- On-screen statistical readout.
- Eight parameter sets available.
- Increased programmable I/O options.
- Built-in Ethernet connectivity.
- PC Windows based software included.
- For use with pneumatic or electric transducerized tools.
- Compatible with: UL-MC Pneumatic, UEP-MC Electric, UOW Nutrunner Series and UAN Angle Series.



UEC-4800



UEC-4800TP Controller with Touch-Screen option.



UEC-4800-EX Controller with network connectivity

### FEATURES AND BENEFITS: UEC-4800TP

- Provides all features of the UEC-4800.
- Enhanced user interface via Touch-Screen programming and information access.

Model	24V I/O	Uryu Data, Barcode & Printer	Ethernet Data only	Light Tower & Bypass Switch Capable	Ethernet Protocols	Serial Protocols or Barcode	DeviceNET	PROFIBUS	Touch Panel Display	Angle Monitoring
UEC-4800	X	X								
UEC-4800TP	X	X							X	
UEC-4800TPA	X	X							X	X
UEC-4800-R	X		X							
UEC-4800-EX	X			X	X	X				
UEC-4800-EXL	X			X	X	X				
UEC-4800-ED	X			X	X		X			
UEC-4800-EDL	X			X	X		X			
UEC-4800-EP	X				X			X		
UEC-4800-EPL	X			X	X			X		
UEC-4800TP-R	X		X						X	
UEC-4800TP-EX	X				X	X			X	
UEC-4800TP-EXL	X			X	X	X			X	
UEC-4800TP-ED	X				X		X		X	
UEC-4800TP-EDL	X			X	X		X		X	
UEC-4800TP-EP	X				X			X	X	
UEC-4800TP-EPL	X			X	X			X	X	
UEC-4800TPA-R	X		X						X	X
UEC-4800TPA-EX	X				X	X			X	X
UEC-4800TPA-EXL	X			X	X	X			X	X
UEC-4800TPA-ED	X				X		X		X	X
UEC-4800TPA-EDL	X			X	X		X		X	X
UEC-4800TPA-EP	X				X			X	X	X
UEC-4800TPA-EPL	X			X	X			X	X	X

Model	Description
UEC-5500	Controller multifunction, 4 tool capacity
UECP-4800A	Controller w/integrated Driver Box for UDP-A60/UDP-A80 series tools

# UEC-4800A/E(SD) CONTROLLER

## FEATURES AND BENEFITS: UEC-4800A/E(SD)

- Economical LCD front panel.
- Easy programming or upload of your program from a PC.
- Torque Wave data visible on your PC.
- UEC-4800(SD) memorizes maximum 12,000 fastening data. When connected to a PC, standard deviations, Cp value, and Cpk values can be analyzed instantly from the stored data within the controller.
- Graph statistical data.



## UEC-4800A/E(SD) SPECIFICATIONS

Power Supply	AC100~240V ±10%	Display	Torque Resolution ±2048 (12-Bit A/D) LCD: 20 characters x 4 lines Contents: Work No., Fastening Count, Down No., Fastening Time, Pulse No. 1-digit digital display (DPM): WORK NO. 4-digit digital display (DPM): TORQUE
Power Frequency	50/60 Hz		
Noise Protection	1000V 1μS (according to noise simulator)		
Insulation Protection	DC500V over 10MΩ		
Ambient Temperature	0~50°C (non-freezing)		
Ambient Humidity	Under 90%RH (no dew)	LED	COUNT Lamp: OK (Green), NOK (Red) TORQUE Lamp: LOW (Yellow), OK (Green), HIGH (Red)
Power Consumption	Approx. 30VA	Input Terminal Signal	Operation Voltage/Current: DC24V/approx. 10mA 6 terminals (free format), VALVE
Weight	Approx. 3.6 kg		
Dimensions	265(d) x 222(w) x 120(h)	Output Terminal Signal	Contact Capacity: AC:125V, 0.3A, DC:30V, 1A 6 terminals (free format), VALVE
Main Functions	Torque Monitoring/Control + Fastening Counter		
Parameter Setup	Manual Input on Front LCD Panel Personal Computer (with setup software)		

## UEC-4800(SD) SERIES BLOCK DIAGRAM

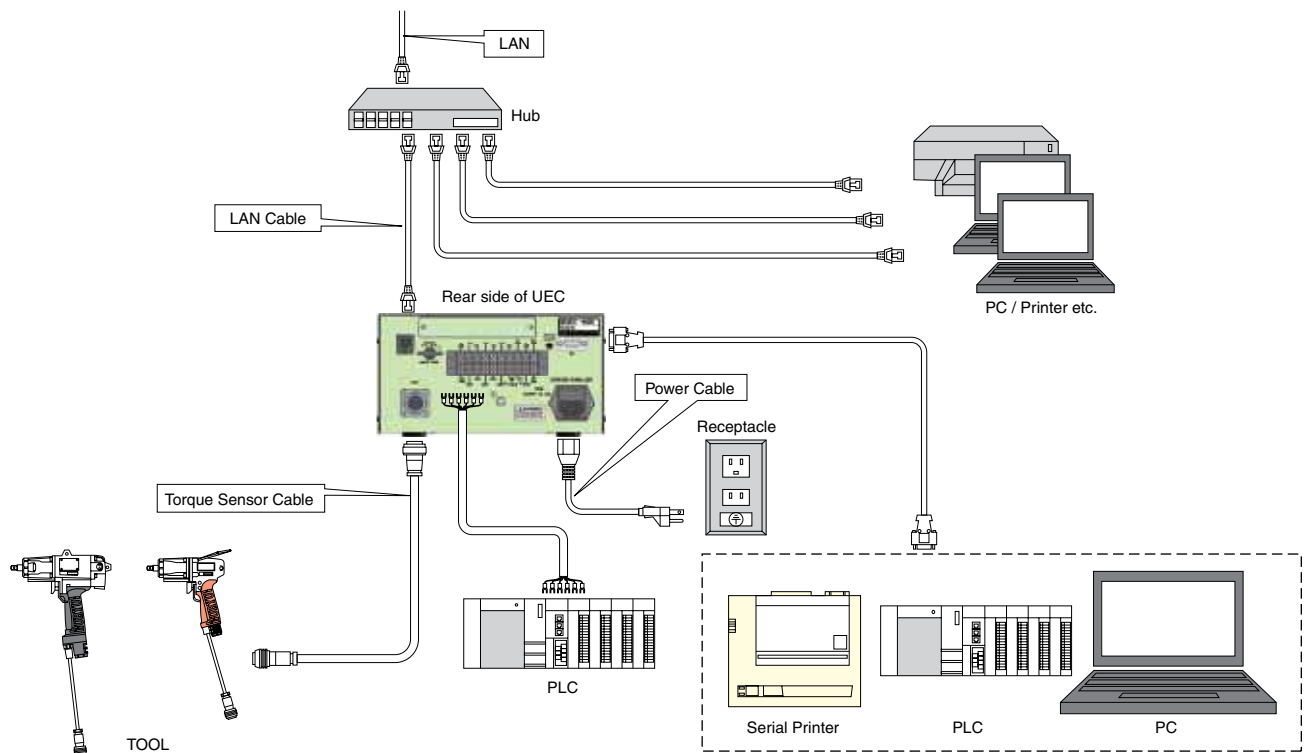



# UEC-4800TPA/E(SD) CONTROLLER

## FEATURES AND BENEFITS: UEC-4800TPA/E(SD)

- Programming is easy on the front touch panel or upload your program from a PC.
- UEC-4800(SD) can be used with various transducerized tools:
  - Oil-Pulse Tools fitted with a Magnetostrictive Transducer UA-MC series, ALPHA-MC Series, UEP-MC Series (UEPD driver is required separately).
  - Oil-Pulse Tools fitted with a Strain-Gauged Transducer U-EC Series, UX-EC Series.
  - Pneumatic Tools fitted with a Strain-Gauged Transducer UAN-M Series, UOW-M Series, UNR-NT Series.
- Highly reliable Torque Control and Monitor.
- Ethernet (TCP/IP) capable.



Torque Wave Monitor Display

## FUNCTIONS: UEC-4800TPA/E(SD)

- Choose between Torque Control and Monitor. Detect various errors and control the job with the fastening counter.
- Torque Wave data visible on both front touch panel and PC.
- UEC-4800(SD) can be used for eight different fastening applications.
- Front panel, PC display, or buzzer indicates Input/Output (terminal blocks and tool wiring), checks and errors.
- UEC-4800(SD) memorizes cumulative fastening numbers and pulse numbers from the start of operation.
- UEC-4800(SD) memorizes maximum 12,000 fastening data. Analyze standard deviations, Cp value, and Cpk value instantly from stored data within the controller. When connected to a PC, statistical data can be graphed.
- Using Input/Output terminals, UEC-4800(SD) can be interlocked with production line.

Torque Monitor Display



## UEC-4800TPA/E(SD) SPECIFICATIONS

Power Supply	AC100 ~ 240V ±10%
Power Frequency	50/60 Hz
Noise Protection	1000V 1μS (according to noise simulator)
Insulation Protection	DC500V over 10MΩ
Ambient Temperature	0 ~ 50°C (non-freezing)
Ambient Humidity	Under 90%RH (no dew)
Power Consumption	Approx. 30VA
Weight	Approx 3.6 kg
Dimensions	265(d) x 222(w) x 120(h)
Main Functions	Torque Monitoring/Control + Fastening Counter
Parameter Setup	Manual Input on Front Touch Panel Personal Computer (with setup software)
Display	Torque Resolution ±2048 (12-Bit A/D) 320 x 240 dot 25 characters X 15 lines
LED	COUNT Lamp: OK (Green), NOK (Red) TORQUE Lamp: LOW (Yellow), OK (Green), HIGH (Red)
Input Terminal Signal	Operation Voltage/Current: DC24V/approx. 10mA 6 terminals (free format), VALVE
Output Terminal Signal	Contact Capacity: AC:125V, 0.3A, DC:30V, 1A 6 terminals (free format), VALVE

The conventional UEC-4800 Series has been superceded by UEC-4800(SD), which has the following new functions:

- 1) miniSD card slot on back panel
  - Fastening data and wave can be saved to miniSD card.
  - Option to save and read setting values in miniSD card.
- 2) Terminal on the rear side. The following terminals are added:
  - 1 x Input terminal
  - 1 x Output terminal
  - 2 x Input COM terminals
  - 2 x Output COM terminals
- 3) Valve Check  
Valve wiring check function checks the valve connection to the terminal. If using ALPHA-MC fitted with the valve inside the tool, it checks the tool valve connection.
- 4) Other Features
  - Increased PC communication speed from 38,400 bps to 115,200 bps.
  - Faster data input and memory deletion.

### (Input Terminal Block)

Signal Allocations
COM: Common Terminal for the input terminals. (-)
IN 1 ~ 6: Input Terminals
IN COM: Common Terminal for the input terminals. (-)
OUT COM: Common Terminal for the output terminals.

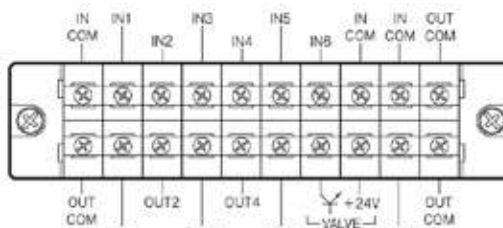

### (Output Terminal Block)

Signal Allocations
COM: Common Terminal for the output terminals.
OUT 1 ~ 5: Output Terminals
VALVE: Valve Output (OV)
VALVE COM: +24V
Out 6: Output Terminal
OUT COM: Common Terminal for the output terminals

# UA-MC SERIES

## SYSTEM LAYOUT

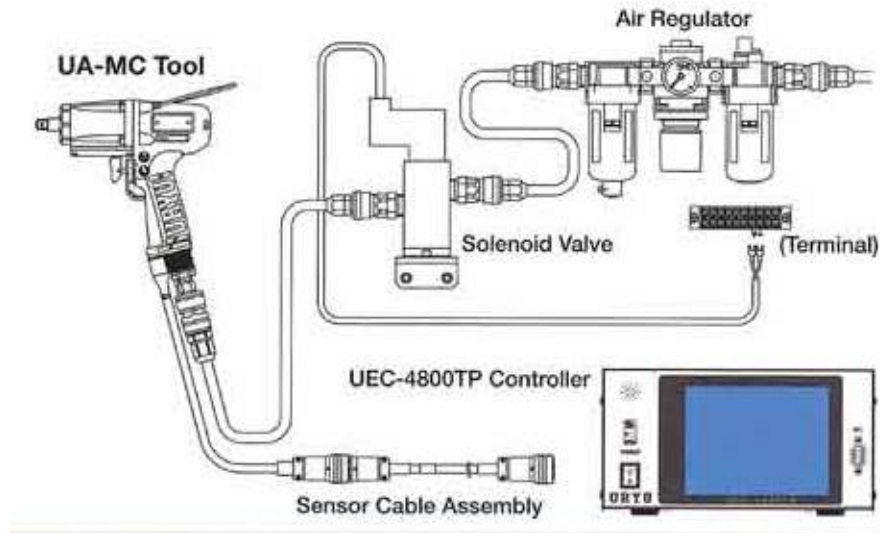

## MAGNETOSTRICTIVE TRANSDUCER

Uryu's brushless Magnetostrictive Torque Transducer consists of an Anvil and a pair of sensor coils. Without contacting the Anvil, the sensor coil detects load to the Anvil (non-contact). The grooves in the Anvil are provided at a 45 degree angle in one region. When torque is applied to the Anvil, tensile stress appears on the region and magnet permeability increases. These permeability changes are detected, respectively transformed to the voltage change (proportional to applied torque) and converted to torque signals to control the tool.

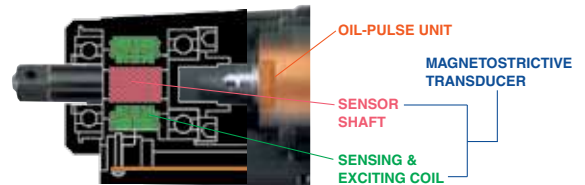

## UA-MC SERIES

### FEATURES AND BENEFITS

- The UA-MC features patented Auto Relief Technology providing additional control to the application of torque during the pulsing events.
- The external solenoid valve increases power-to-weight ratios by 20%.
- Magnetostrictive Transducer provides increased durability with low size and weight.
- Pulse Tool requirements with Controlled Tool advantages.
- All models work with any UEC Series controller and can connect to a wide range of network protocols.
- With torque reaction virtually non-existent, allowing for a one-handed operation, the UA-MC provides significantly increased productivity.



RECOMMENDED AIR PRESSURE: 85 PSI

MODEL #	TORQUE RANGE		FREE SPEED RPM	LENGTH		WEIGHT		DRIVE SIZE IN	AIR USAGE CFM
	NM	FT-LB		MM	IN	LB	KG		
UA-40MC	7.5 - 13	5.5 - 9.6	3,600	170	6.7	1.1	2.4	3/8	7
UA-40DMC	5 - 12	3.7 - 8.9	3,600	170	6.7	1.1	2.4	1/4 QC	7
UA-50MC	11 - 25	8.1 - 18.4	4,250	170	6.7	1.1	2.4	3/8	8.8
UA-60MC	18 - 38	13.3 - 28	5,000	175	6.9	1.1	2.5	3/8	14
UA-70MC	30 - 50	22.1 - 36.9	5,700	187	7.4	1.2	2.7	3/8	15.8
UA-80MC	40 - 60	29.5 - 44.3	6,000	195	7.7	1.6	3.4	3/8	17
UA-90MC	40 - 80	29.5 - 59	5,500	203	7.9	1.7	3.7	1/2	18.6
UA-100MC	50 - 90	36.9 - 66.4	5,200	215	8.5	2.1	4.5	1/2	19.3
UA-130MC	85 - 130	62.7 - 95.9	4,500	233	9.2	2.8	6.2	1/2	25.6

# UA-AMC SERIES

## SYSTEM LAYOUT

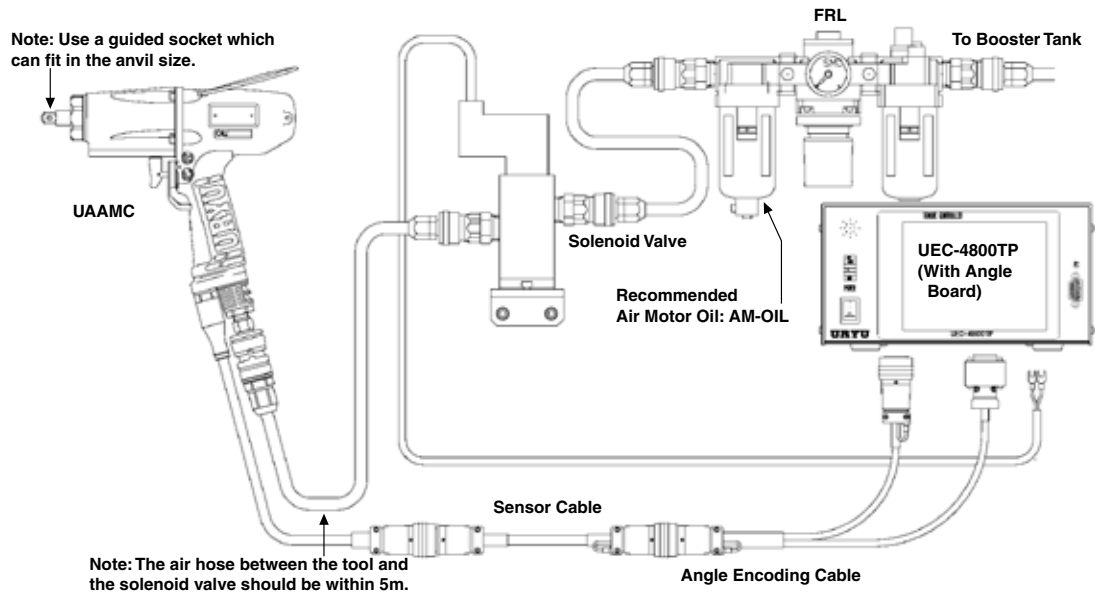

## UA-AMC SERIES

### FEATURES AND BENEFITS

- The UA-AMC features angle measurement for improved process control.
- No torque reaction.
- The UA-AMC Series detects cross threading, double hits on the same fastener, stripped and damaged fastener threads and incorrect fasteners for an application.
- Two Angle Resolver types: External Resolver and Transducer Integrated Resolver.
- The UA-AMC features patented Auto Relief Technology providing smooth delivery of torque during pulsing events.
- Triple chamber air motors for high power output in UA-400AMC, UA-500AMC and UA-600AMC models.
- UEC4800 controllers can easily be upgraded to angle capable models. Contact your AIMCO representative for details, 1-800-852-1368.



RECOMMENDED AIR PRESSURE: 85 PSI

MODEL #	TORQUE RANGE		FREE SPEED RPM	LENGTH		WEIGHT		DRIVE SIZE IN	AIR USAGE CFM
	NM	FT-LB		MM	IN	LB	KG		
UA-400AMC	7 - 13	5.2 - 9.6	3,600	193	7.6	3.0	1.6	3/8	7.1
UA-500AMC	11 - 25	8.1 - 18.4	4,250	193	7.6	3.0	1.6	3/8	8.8
UA-600AMC	18 - 38	13.3 - 28.0	5,000	198.5	7.8	3.1	1.4	3/8	14.1
UA-700AMC	30 - 50	22.1 - 36.9	5,700	207.5	8.2	3.3	1.5	3/8	15.9
UA-800AMC	40 - 60	29.5 - 44.3	6,000	215.5	8.5	3.8	1.7	3/8	17.0
UA-900AMC	50 - 90	36.9 - 66.4	5,500	232.5	9.2	4.9	2.2	1/2	18.7
UA-1000AMC	50 - 90	36.9 - 66.4	5,200	242.5	9.6	5.5	2.5	1/2	19.4
UA-1300AMC	85 - 130	62.7 - 95.9	4,500	236	9.3	7.3	3.3	1/2	25.8

# UEP-MC SERIES

## SYSTEM LAYOUT

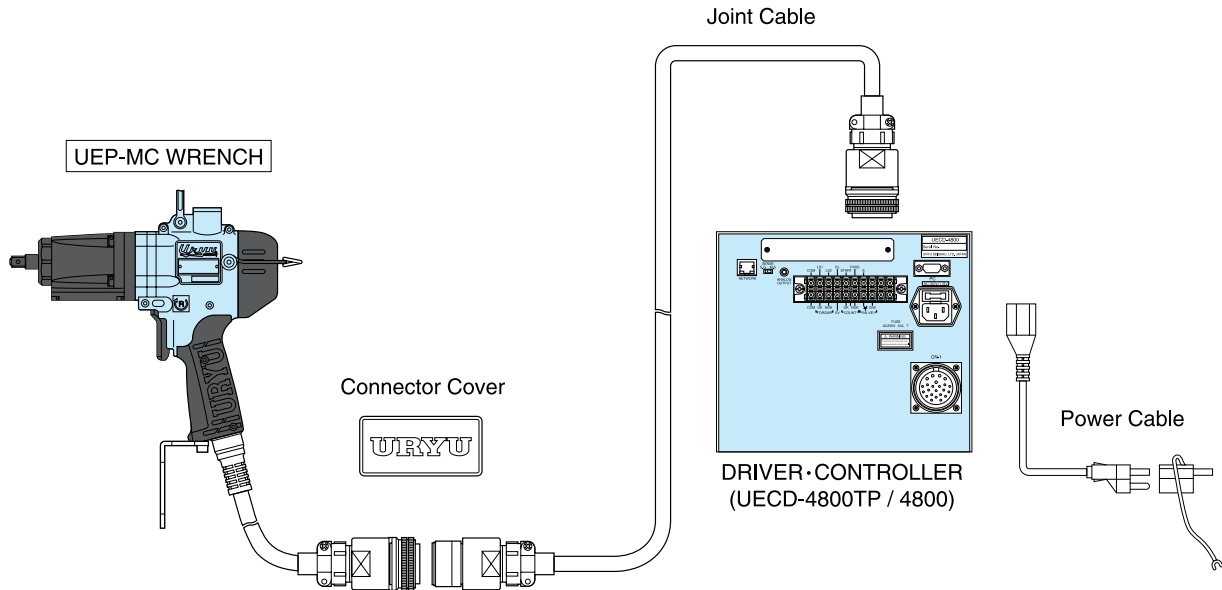

Uryu's unique feature, a non-contact and Magnetostrictive Transducer, provides tightening and fastening counter monitoring controlled by a highly accurate torque control mechanism connected to the multi-functional UECD-4800 Series controller (This is a combination unit of UEC-4800 and UEPD driver box).

## UEP-MC SERIES

### FEATURES AND BENEFITS

- Operates on standard 110V or 220V power.
- Extremely durable, brushless motor.
- Programmable tool RPM for increased accuracy and adjustability to joint conditions.
- Two stage trigger for separate, slower RPM for soft start applications.
- Quiet operation.
- I/O capability for programmable line control.
- Pulse tool advantages on applications that require controlled electric tools.



MODEL	TYPE	TORQUE RANGE		FREE SPEED RPM	WEIGHT LB	LENGTH IN	DRIVE IN	SOUND LEVEL DB(A)	REQUIRED DRIVER BOX
		NM	FT-LB						
UEP-50MC(-STDA)*	TRANSDUCERIZED	5 - 10	4 - 7	2,000	4.0	7.9	3/8 SQ. DR.	70	UEPD-51A-UL
UEP-50DMC(-STDA)*	TRANSDUCERIZED	5 - 10	4 - 7	2,000	4.0	7.9	1/4 HEX	70	UEPD-51A-UL
UEP-60MC(-STDA)*	TRANSDUCERIZED	10 - 25	8 - 18	2,000	4.7	8.7	3/8 SQ. DR.	70	UEPD-61A-UL
UEP-60DMC(-STDA)*	TRANSDUCERIZED	10 - 25	8 - 18	2,000	4.7	8.7	1/4 HEX	70	UEPD-61A-UL
UEP-70MC(-STDA)*	TRANSDUCERIZED	25 - 40	18 - 30	2,000	5.2	8.4	3/8 SQ. DR.	72	UEPD-71A-UL
UEP-80MC(-STDA)*	TRANSDUCERIZED	30 - 60	22 - 44	2,000	6.6	8.4	1/2 SQ. DR.	75	UEPD-71A-UL
UEP-100MC(-STDA)*	TRANSDUCERIZED	60 - 120	44 - 88	2,000	9.2	9.9	1/2 SQ. DR.	75	UEPD-101A-UL

\* Add "-STDA" to part numbers to include tool, driver box, and driver cable (components can be sold individually).

# UECP-4800 CONTROLLER AND UDP-MC SERIES

## UECP-4800

### FEATURES AND BENEFITS

- **Power Supply:** UDP tool is driven by commercial electricity, providing flexible assembly line changes.
- **Light Weight:** The housing is made from plastic and designed to be light and rugged.
- **Motor:** High power and high efficiency adopted by IPM motor.
- **Automatic Ventilation System:** Cooling fan is activated automatically when pulling the throttle trigger, which reduces heat and increases fastening count.
- **Pulse Unit:** A newly developed Auto Relief Function is included.
- **Safety:** To protect the operator, the iUDP-MC tool stops operation immediately when failure is detected, including overloaded operation, short circuit, and broken wire.



The UECP-4800 is an exclusive controller for UDP-MC Series, so it cannot be connected to other MC/EC tools.

### UECP-4800 FUNCTIONS AND SPECIFICATIONS

- **Motor Setting**
  - Motor current can be set in four steps.
  - Motor rotational speed can be set in 100 rpm increments.
- Fastening error detection and fastener number countdown functions ensure seamless operation.
- Allows setup or changeover of fastening torque and fastening number count.
- Tool's maintenance is possible by counting both total cycle numbers (how many fasteners) and/or total pulse numbers.
- Input/Output check and error messages can be checked from your PC or the front panel of UECP-4800, which will notify you with a buzzer.
- Can set up and monitor various control values. Values can be set either on the front panel or on the PC.
- Ethernet (TCP/IP) capable. Upload and receive setting values. Upload fastening result/waveform data through PC software.

Power Supply	AC100~240V ±10%
Power Frequency	50/60 Hz
Noise Protection	1000V 1μS (according to noise simulator)
Insulation Protection	DC500V over 10MΩ
Ambient Temperature	0~50°C (non-freezing)
Ambient Humidity	90%RH or less (no dew)
Weight	Approx. 11.30 kg
Dimensions	265(d) x 222(w) x 200(h)
Main Functions	Torque control, Torque monitoring, Fastener number count
Parameter Setup	Manual Input on Front LCD Panel PC (with exclusive setup software)
Display	Torque Resolution ±2048 (12-Bit A/D use) LCD type, 20 characters x 4 lines Contents: Work No., Bolt Count No., Tightening Time, Pulse Blow Number 1-digit digital display (DPM): Work No. displayed 4-digit digital display (DPM): Torque reading displayed
LED	Total Lamp (for count judgment): OK (Green), NOK (Red) Torque Lamp (for torque judgment): LOW (Yellow), OK (Green), HIGH (Red)
Input Terminal Signal	Operation Voltage/Current: DC24V, approx. 10mA 6 terminals available (programmable). Note: Contact input necessary
Output Terminal Signal	Contact Capacity: DC 30V, 1A 6 terminals available (programmable), VALVE

## UDP-MC SERIES

### FEATURES AND BENEFITS

- High speed for increased productivity.
- No torque reaction.
- Magnetostrictive Transducer provides increased durability with low size and weight.
- Auto relief pulse mechanism for measured application of tightening energy.
- Durable 11mm cable.
- Use with UECP-4800A Controller with integrated driver box



UDP-A80MC

MODEL	TYPE	TORQUE RANGE		FREE SPEED RPM	WEIGHT LB	LENGTH IN	DRIVE IN	SOUND LEVEL DB(A)	REQUIRED DRIVER BOX
		NM	FT-LB						
UDP-A60LMC		4 - 20	2.9-14.4	1000-4800	3.3	8.4	3/8 SQ. DR.	74	
UDP-A60MC	TRANSDUCERIZED	5 - 25	3.7 - 18.5	1,000 - 4,800	3.3	8.4	3/8 SQ. DR.	74	N/A
UDP-A80MC	TRANSDUCERIZED	25 - 55	18.5 - 40.6	1,000 - 4,800	3.9	9.5	3/8 SQ. DR.	76	N/A
UDP-A100MC		UNDER DEVELOPMENT							

# ACRA-PULSE® MC & EC SERIES

## ACRA-PULSE® MC SERIES



UXR-1820MC

MODEL	TORQUE RANGE		FREE SPEED RPM	LENGTH		WEIGHT		DRIVE IN	NOISE LEVEL DB(A)	AIR USAGE CFM
	NM	FT-LB		MM	IN	LB	KG			
ALPHA-50DMC*	6 - 15	4.5 - 11	5,700	193	7.6	2.9	1.3	1/4 HEX	82	7.1
ALPHA-50MC*	6 - 15	4.5 - 11	5,700	193	7.6	2.9	1.3	3/8	82	7.1
ALPHA-60DMC	9 - 20	7 - 14	7,000	205	8.1	3.1	1.4	1/4 HEX	82	8.8
ALPHA-60MC	9 - 20	7 - 14	7,000	205	8.1	3.1	1.4	3/8	82	8.8
ALPHA-60SDMC	10 - 17	7 - 12	5,500	280	11.0	2.8	1.2	1/4 HEX	82	8.8
ALPHA-60SMC*	10 - 17	7 - 12	5,500	280	11.0	2.8	1.2	3/8	82	8.8
ALPHA-70MC	12.5 - 30	9 - 22	7,000	205	8.1	3.1	1.4	3/8	82	12.3
ALPHA-80MC	16 - 40	12 - 29	7,000	221	8.7	3.3	1.5	3/8	82	15.8
ALPHA-90MC	20 - 47	14 - 34	6,500	221	8.7	3.3	1.5	3/8	82	15.8
ALPHA-101MC	34 - 70	25 - 51	6,200	233	9.2	4.6	2.1	1/2	82	17.6
ALPHA-110MC	45 - 100	33 - 72	5,000	249	9.8	5.5	2.5	1/2	82	22.9
ALPHA-130MC	80 - 150	59 - 110	3,400	266	10.5	7.7	3.5	1/2	82	22.9
ALPHA-140MC	140 - 220	103 - 162	3,500	295	11.6	10.2	4.6	3/4	82	28.3
UXR-1820MC	140 - 250	103 - 184	4,600	322	12.3	12.3	5.5	3/4	84	24.7
UXR-2000MC	200 - 400	148 - 295	4,800	355	14.0	17.6	8.0	3/4	84	33.6
UXR-2400SMC	300 - 600	221 - 443	3,300	416	16.4	27.6	12.5	1	85	35.3

Air Hose Size: 3/8" I.D.  
1/2" I.D. FOR UXR-1820MC/2000MC/2400SMC  
\* External Solenoid Valve (909-749-0) Required

Air Inlet: N.P.T. 1/4"  
N.P.T. 3/8" FOR UXR-1820MC; N.P.T. 1/2" FOR UXR-2400SMC

RECOMMENDED AIR PRESSURE: 85 PSI



UX-80EC

## ACRA-PULSE® EC SERIES

RECOMMENDED AIR PRESSURE: 85 PSI

MODEL	TORQUE RANGE		FREE SPEED RPM	LENGTH		WEIGHT		CENTER TO OUTSIDE		DRIVE IN	NOISE LEVEL DB(A)	AIR USAGE CFM
	NM	FT-LB		MM	IN	LB	KG	MM	IN			
U-50EC	4 - 10	3 - 7	2,100	195	7.7	3.3	1.5	21	0.8	3/8	78	10.2
U-50DEC	4 - 10	3 - 7	2,100	201	7.9	3.3	1.5	21	0.8	1/4 HEX	78	10.2
U-50SDEC*	4 - 10	3 - 7	2,100	280	11.5	3.4	1.6	21	0.8	1/4 HEX	72	7.7
U-50SEC*	4 - 10	3 - 7	2,100	280	11.2	3.4	1.6	21	0.8	3/8	72	7.7
U-60EC	15 - 30	11 - 22	1,900	193	7.6	3.5	1.6	27	1.1	3/8	78	14.1
U-60DEC	15 - 30	11 - 22	1,900	305	12.0	4.4	2.0	27	1.1	1/4 HEX	75	12.3
U-60SEC*	15 - 25	11 - 18	1,900	305	12.0	4.4	2.0	27	1.1	3/8	82	14.1
UX-80EC	25 - 45	18 - 33	1,900	197	7.8	4.0	1.8	30	1.2	3/8	80	17.7
U-100EC	50 - 80	36 - 59	1,700	233	8.2	6.2	2.8	33	1.3	1/2	80	24.7
UX-120EC**	65 - 120	47 - 88	900	253	10.0	8.6	3.9	36	1.4	1/2	77	28.2
UX-130EC	90 - 170	65 - 123	1,250	273	10.8	10.4	4.7	40	0.6	1/2	79	35.0

Air Hose Size: 3/8" I.D.  
\*\* Recommended air pressure for UX-120EC: 50 - 57 psi  
\* External Solenoid Valve (909-749-0) required

Air Inlet: N.P.T. 1/4"

NOTE: Torque ranges reflect residual B joint torque values

# UEC-4800 CONTROLLER ACCESSORIES

## UEC-4800 CONTROLLER BRACKETS

- Provides a stable platform for the UEC 4800 Controller.
- Flexible mounting configurations for ease of access and operator viewing.
- Optional accessory bracket provides compact storage of light tower and accessories with Controller.
- Durable, Powder Coat finish.

UEC-4800TRAY Complete Assembly for Standard Controllers and Light Towers/Accessories

MODEL	DESCRIPTION
24582	Advanced Communication Enabled Controller Hold Down Bracket
24588	Controller Tray Mount
24587	Wall Mount
24583	Standard Controller Hold Down Bracket
24586	Light Tower/Accessory Bracket



## PROGRAMMABLE PNEUMATIC REGULATOR

- Provides enhanced control for pneumatic assembly tools.
- Enables downshifts with controlled air tools.
- Automatically changes air pressure when programmed Start Torque (threshold) value is reached.
- Can be programmed to switch from high pressure to low pressure or from low pressure to high pressure.
- Excellent for use on extremely hard or extremely soft joints.
- Can be programmed to fully disable tool via PLC input.
- Link to other devices such as a four-position socket tray.



# CABLES



CABLE PART #	DESCRIPTION OF CABLES
UK-ACEA1-10	Encoder Cable 10m
UK-ACEA1-25	Encoder Cable
UK-ACEA1-3	Encoder Cable 3m
UK-ACEA1-5	Encoder Cable 5m
UK-ACEA2-3	Cable
UK-ACEB1-10U	Motor Cable 10m UI
UK-ACEB1-25	Cable
UK-ACEB1-3U	Motor Cable 3m UI
UK-ACEB1-5U	Motor Cable 5m UI
UK-ACEB2-3	Cable
UK-ACEC1-10	Controller Cable 1m
UK-ACEC1-15	Controller Cable 1.5m
UK-ACEC1-20	Controller Cable 2m
UK-ACFA1-20	UI Power Cable (20M)(UL)
UK-ACFA3-5	Extension Power Cable
UK-ACFB1-20	Sensor Cable 20m
UK-ACFB4-10	Sensor Extension Cable
UK-ACFB4-5	Extension Power Cable
UK-AL-5	Cable Assembly



# TORQUE MEASUREMENT: OVERVIEW

**TORQUE MEASUREMENT AND THE VERIFICATION OF TORQUE TOOLS AND APPLIED TORQUE ARE AN INTEGRAL PART OF TODAY'S THREADED ASSEMBLY PROCESS.** The method used to measure torque can affect the judgments made regarding tool performance, assembly processes and overall product quality.

## DYNAMIC TORQUE

The torque produced during the actual tightening process, normally measured using rotary transducers and a torque analyzer. **Advantages:**

- Reduces operator influence.
- Measures applied torque.
- Can also include angle of rotation as error proofing parameter.

## RESIDUAL TORQUE

The torque measured by producing an incremental amount of movement of the fastener after the actual tightening process, normally measured using a dial or digital torque wrench. **Advantages:**

- Easy access to fastener.
- Error proofing.
- Can detect missed fasteners or joints with significant relaxation.

### HARD JOINT

Less than 30° degrees of rotation

Metal Metal

Metal Metal

AUDIT METHOD

OR

Dynamic Torque: 15 Nm      Residual Torque: 18 Nm

Values as examples only

A hard joint, one requiring a low degree of rotation during tightening, will normally show very little relaxation after tightening. Due to the high amount of remaining clamp load and friction within the joint members, additional movement of the fastener requires additional torque energy to be applied. Therefore, Residual Torque values will be higher than Dynamic Torque values.

### SOFT JOINT

720° degrees or more of rotation

Metal Metal

Gasket Gasket

Metal Metal

AUDIT METHOD

OR

Dynamic Torque: 15 Nm      Residual Torque: 12 Nm

Values as examples only

A soft joint, one requiring a high degree of rotation during tightening, will normally show significant amounts of relaxation after tightening. Relaxation leads to a loss of clamp load and friction within the joint members. Due to this relaxation, additional movement of the fastener requires relatively small amounts of additional torque energy and Residual Torque values will be lower than Dynamic Torque values.

# TORQUE MEASUREMENT: OVERVIEW

**CHECKING TORQUE MEASUREMENT BEFORE, DURING, AND AFTER ASSEMBLY ENSURES QUALITY MANUFACTURING.** Proper torque measurement is critical in many assembly operations. AIMCO utilizes years of experience to design a process around your specific auditing requirements. From simple dial wrenches to electronic data collectors and joint analyzers for R&D, AIMCO is with you every step of the way.

## **BEFORE ASSEMBLY** – TOOL CAPABILITY

### ***Is the tool working correctly?***

Testing and verifying tools under controlled conditions. Identify the accuracy & repeatability of the tool before using it in production.

#### **Equipment used:**

- Desktop testers with internal transducers.
- Auditor™ analyzers with either stationary or rotary transducers.
- UFT hydraulic joint simulators and rotary transducers.

## **PRODUCTS TO USE...**



## **DURING ASSEMBLY** – PROCESS CAPABILITY

### ***How does the tool work with the product being assembled?***

Testing the tools during the actual process helps ensure that the process is working correctly. This is where variables in the parts and influences from the operator can be accounted for.

#### **Equipment used:**

- Torque Data Collectors/Analyzers
- Auditor™ Rotary Transducers



## **AFTER ASSEMBLY** – PRODUCT CAPABILITY

### ***Does the finished product meet the user's expectations?***

Checking the product after assembly is the final opportunity to check the product prior to user delivery. This is the way to verify that product quality is satisfactory.

#### **Equipment used:**

- Click/Dial wrenches
- Electronic wrenches with Auditor™ analyzers.
- Rotary transducers and Auditor™ analyzers with hand driver to move fastener.



# TORQUE MEASUREMENT: OVERVIEW

## MEASURING QUALITY – PROCESS CAPABILITY

### STATISTICAL ANALYSIS IS AN IMPORTANT STEP IN ANY QUALITY CONTROL PROCESS.

One of the most widely accepted statistical indicators of process quality, and therefore product quality, is Cpk, or the process capability for a centered process. This value indicates how capable a process is and whether the results of that process are properly centered near a specific target. A capable process is one that approaches, as a limit, 100% conformance to specifications.

Cpk is a statistical value that indicates how tightly grouped a series of samples is around the target value. Cpk is a function of the Upper Specification Limit (USL), the Lower Specification Limit (LSL), the mean of the samples and the standard deviation ( $\sigma$ ) of the samples.

$$Cpk = \text{either } \frac{(USL - \text{Mean})}{(3 \times \sigma)} \text{ or } \frac{(\text{Mean} - LSL)}{(3 \times \sigma)}, \text{ whichever is smaller.}$$

**An acceptable, or capable, process will normally have a Cpk value of at least 1.33.**

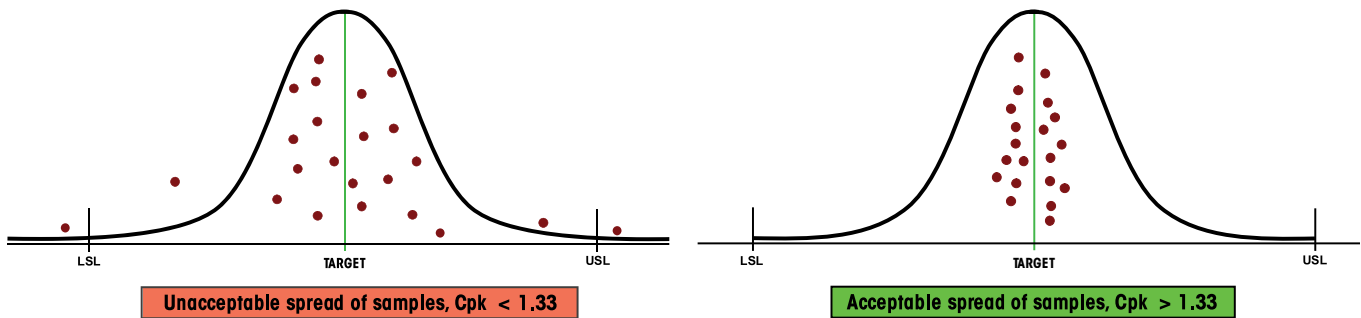

## MEASURING QUALITY – CLAMP LOAD

### THE PURPOSE OF THREADED FASTENING IS TO PRODUCE THE CORRECT AMOUNT OF CLAMP LOAD WITHIN THE JOINT.

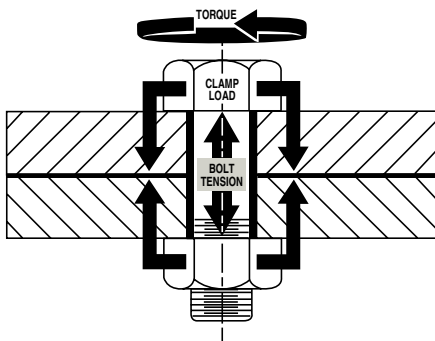

Due to the cost and difficulty of measuring clamp load during the actual assembly process, torque is used as the control parameter during tightening.

Many manufacturers use torque values as the primary indicator of threaded assembly quality. However, achieving repeatable clamp load is a better indicator of joint quality.

Studies have shown that discontinuous drive tools can produce equal or better clamp load results when compared to continuous drive tools.

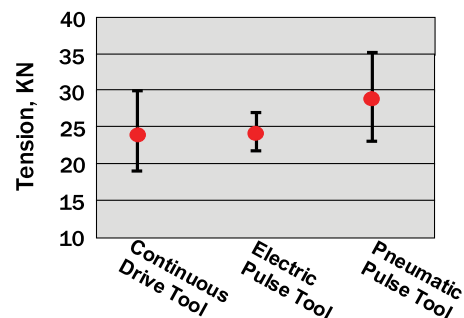
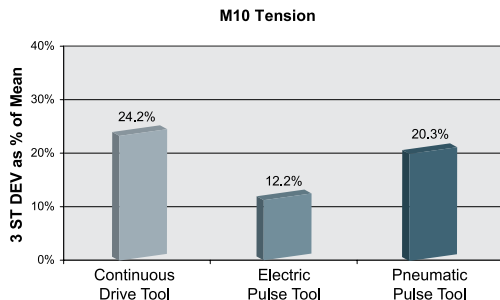

# AUDITOR™ TORQUE CUBE™



ATC-10  
ATC-25  
ATC-100  
ATC-250  
ATC-500



ATC-750F



## AUDITOR™ TORQUE CUBE™

The Auditor Torque Cube (ATC) is a compact, versatile desktop tester and provides a multitude of capabilities. The ATC is designed to test hand or power tools with the following:

- Peak, first peak and track modes.
- Multiple engineering units.
- Manual & auto clear function.
- Multiple frequency response settings.
- Bi-directional use & accuracy.
- Accuracy is better than 1% of indicated reading top 90% of range.
- Serial data output.
- Memory 999 data samples.
- Battery and/or mains powered.

Because precision and quality are important, our testers can be depended on to calibrate and certify your torque tools. Whether you are assembling large complicated systems or small precise time pieces, AIMCO provides the best system for your application. Our instruments have been judged “best in class” by independent National Standards laboratories. The Auditor Torque Cube is rugged enough to test and verify tools at “point of use” while still being accurate enough to calibrate hand and power tools in the calibration laboratory.

Each tester is shipped with a mains/battery charger power cord, a joint rundown fixture, a hex to allen drive bit and a bolting template. The ATC can be positioned vertically or horizontally for the ergonomic testing of inline or pistol grip tools.

MODEL	MAX TORQUE		WEIGHT		W X H X D		SQUARE DRIVE
	Nm	in-lb	kg	lb	mm	in	
ATC-10	1.13	10	1.13	2.5	79x95x83	3.13x3.75x3.25	1/4
ATC-25	2.8	25	1.13	2.5	79x95x83	3.13x3.75x3.25	1/4
ATC-100	11.3	100	1.13	2.5	79x95x83	3.13x3.75x3.25	1/4
ATC-250	28.25	250	1.13	2.5	79x95x83	3.13x3.75x3.25	3/8
ATC-500	56.5	500	1.13	2.5	79x95x83	3.13x3.75x3.25	3/8
ATC-250F	339	250 ft-lb	2.25	5	79x95x83	3.13x3.75x3.25	1/2
ATC-750F	1017	750 ft-lb	2.25	5	79x95x83	3.13x3.75x3.25	3/4

# AUDITOR™ DESKTOP TESTERS



AUET



AUET/MTM



AUET/MTM-DC

## AUDITOR™ UNIVERSAL ELECTRONIC TESTERS

The Auditor Universal Electronic Testers (AUET) have a broad range of features to accommodate most requirements. These instruments are designed to be bench top mounted and are available in several configurations and various single or multiple torque ranges. They are also available with file capability, (DC) models. The DC models require PC software Auditor Tool Manager (ATM).

units are supplied with an external transducer port and selector switch for connecting additional transducers.

These AUET instruments utilize the same transducers that are featured in the ATC instruments, providing the same high quality in accuracy and durability. Auditor testers use a common interface making it extremely user friendly.

Instruments up to 1000 in-lb are supplied with rundown adapters/joint kits. Rundown kits for larger instruments can be ordered separately. AUET/MTM



### SINGLE TRANSDUCER MODELS

MODEL**	RECOMMENDED TORQUE RANGE			
AUET-0100(-DC)	10 - 100	in-oz	0.7 - 7.2	kgf-cm
AUET-10(-DC)	1 - 10	in-lb	1.1 - 11.5	kgf-cm
AUET-50(-DC)	5 - 50	in-lb	0.5 - 5.6	Nm
AUET-100(-DC)	10 - 100	in-lb	1.1 - 11.3	Nm
AUET-250(-DC)	25 - 250	in-lb	2.8 - 28.3	Nm
AUET-1000(-DC)	100 - 1,000	in-lb	11.3 - 113	Nm
AUET-1200(-DC)	120 - 1,200	in-lb	13.6 - 135.6	Nm

### DUAL TRANSDUCER MODELS

MODEL**	RECOMMENDED TORQUE RANGE			
	Transducer 1	Transducer 2	Transducer 1	Transducer 2
AUET/MTM-10-100(-DC)	1.0 - 10 in-lb	10 - 100 in-lb	0.11 - 1.12 Nm	1.3 - 11.3 Nm
AUET/MTM-50-250(-DC)	5.0 - 50 in-lb	25 - 250 in-lb	0.56 - 5.65 Nm	2.8 - 28.3 Nm
AUET/MTM-50-500(-DC)	5.0 - 50 in-lb	50 - 500 in-lb	0.56 - 5.65 Nm	5.65 - 56.49 Nm
AUET/MTM-100-500(-DC)	10 - 100 in-lb	50 - 500 in-lb	1.13 - 11.3 Nm	5.65 - 56.49 Nm
AUET/MTM-100-1000(-DC)	10 - 100 in-lb	100 - 1,000 in-lb	1.13 - 11.3 Nm	11.3 - 113 Nm

\*Custom sizes are also available, please inquire.

\*\*Add "-DC" to part numbers for data collecting models.

**Data collecting models allow multiple files/tools/applications to be associated with torque data. Requires Tool Manager software.**

# AUDITOR™ TORQUE DATA ANALYZERS



ATDA-DC

## AUDITOR™ TORQUE DATA ANALYZERS

Our torque tester is the Auditor Torque Data Analyzer (ATDA) DC designed to be portable or conveniently placed on a bench. Depending on requirements, the tester can be connected to various transducers. In addition, it can be connected to transducerized wrenches, rotary or stationary transducers. The user interface is common between the ATC (Cube), AUET, AUET-DC, AUET/MTM, AUET/MTM-DC, ATDA and ATDA-DC. All of these instruments have very similar menus, additionally, all data collector testers utilize Auditor Tool Manager for tool testing and test data management.

The Auditor Torque Data Analyzer is available in three configurations:

- ATDA: A simple torque analyzer with sequential memory, 999 data samples, engineering limits, limited statistical processing average, range, Cp and CpK with serial output.
- ATDA-S: A simple torque analyzer with sequential memory and data streaming capability for creating rundown graphics in Excel or Word.
- ATDA-DC: Contains all of the features of the ATDA and has additional file capability. Is able to associate data with file names and manage data collection using a computer and the Auditor Tool Manager software.

This is a great “starter” tool management system, providing testing, archiving and analysis of tools at single or multiple torque targets. The tool and torque data is stored in a SQL database and can be exported to Excel or any .csv spreadsheet application.



MODEL	DESCRIPTION
ATDA	Auditor Torque Data Analyzer
ATDA-DC	Auditor Torque Data Collector
ATDA-S	Auditor Torque Data Streaming Unit

# AUDITOR™ TORQUE DATA ANALYZERS



## TOUCH SCREEN AUDITOR™ TORQUE DATA ANALYZERS

Auditor offers the ATDA-8000 and the ATDA-8000-10. The ATDA-8000 is a touch screen instrument with a high resolution display and user interface that facilitates “point of use” tool validation. The user interface is intuitive and the display provides clear easy to read data. Features and parameter settings are password protected to ensure parameters cannot be inadvertently changed. After initial setup the

instrument provides semi-automatic tool validation and judgment.

The ATDA-8000 is a single channel instrument – the ATDA-8000-10 is a larger instrument that includes a multiplexor for connection to multiple transducers allowing a wide range of tools to be tested with one instrument. Both systems work with AIMCO's line of digital transducers.



MODEL	DESCRIPTION
ATDA-8000	Auditor Torque Analyzer Single channel touch screen point of use validation system
ATDA-8000-10	Auditor Torque Analyzer Multiple transducer touch screen point of use validation system

# AUDITOR™ TRANSDUCERS



Stationary Transducers with joint rundown fixtures and where applicable bench stands.

## AUDITOR™ TRANSDUCERS – Stationary, Rotatables, Rotary, Wrenches “Transducers on a Stick” Analog and Digital transducer models available

AIMCO offers multiple styles of transducers with various configurations depending on application requirements. We offer IS (industry standard transducers 2mv/v), Intelligent transducers for Crane instruments (UTA), Intelligent IS transducers for Auditor instruments (these work as intelligent when connected to our instruments but as IS when connected to other manufacturer's instruments – no need for multiple sets of transducers due to multiple analyzers. AIMCO also offers digital

torque transducers and a new concept in dynamic torque testing – wireless rotatable torque transducers. This list is a partial list of what we have available.

\*Please refer to the Stationary Transducer in the Appendix A for required ordering options.

Please contact our Customer Service Associates for additional information, 1-800-852-1368.

STATIONARY TRANSDUCER	MAX TORQUE		WEIGHT		W X H X D		SQUARE DRIVE
	Nm	in-lb/ft-lb	kg	lb	mm	in	in
AISI-200025	2.8	25	1.13	2.5	79x95x83	3.13x3.75x3.25	1/4
AISI-200100	11.3	100	1.13	2.5	79x95x83	3.13x3.75x3.25	1/4
AISI-200500	56.5	500	1.13	2.5	79x95x83	3.13x3.75x3.25	3/8
AISF-200100	135.6	1,200/100	2.25	5	100x65	4x3	1/2
AISF-200250	339	3,000/250	2.25	5	100x65	4x3	1/2
AISF-201000	1350	12,000/1,000	2.8	6	100x65	4x3	1

DRIVE SIZE - IN	MAX TORQUE		STATIONARY – SMART	STATIONARY – IS
1/4	5.6 Nm	50 in-lb	ASTU-25D-6	
1/4	11 Nm	100 in-lb	ASTU-25D-11	ASTIS-25D-11
1/4	28 Nm	250 in-lb	ASTU-25D-28	ASTIS-25D-28
3/8	67 Nm	50 ft-lb	ASTU-38D-67	
3/8	135 Nm	100 ft-lb	ASTU-38D-135	ASTIS-38D-135
1/2	270 Nm	200 ft-lb	ASTU-50D-270	ASTIS-50D-270
3/4	540 Nm	400 ft-lb	ASTU-75D-540	
3/4	1017 Nm	750 ft-lb	ASTU-75D-1000	ASTIS-75D-1000
1	1695 Nm	750 ft-lb	ASTU-100D-1700	ASTIS-100D-1700



# AUDITOR™ TRANSDUCERS



Rotary UTA



Rotary Intellect/IS AIR\*\*



Rotary UTA

Model*	Max Torque		Weight		Size		Square Drive in
	Nm	in-lb/ft-lb	kg	lb	mm	inch	
AIRI-200050	5.85	50	1	2.5	50x75	2x3	1/4
AIRI-200500	56.5	500	1	2.5	50x75	2x3	3/8"
AIRF-200100	135.6	1,200/100	1.5	3.3	75x100	3x4	1/2"
AIRF-200500	678	6,000/500	2.2	5	75x100	3x4	3/4"
AIRF-201000	1356	12,000/1,000	3	6.5	75x100	3x4	1"

\*Insert (T) after the hyphen to indicate torque angle transducers.

\*\*Please refer to the Transducer Configurator in the Appendix A for required ordering options.

DRIVE	MAX TORQUE		ROTARY – SMART	ROTARY – IS	TORQUE ANGLE*	LENGTH (A)	THICKNESS (B)	WIDTH (C)	WEIGHT lb
1/4 Hex	2 Nm	18 in-lb	ARTU-25H-2T	ARTIS-25H-2T	A	4.6	1.1	2.2	1.0
1/4 Hex	5 Nm	44 in-lb	ARTU-25H-5T	ARTIS-25H-5T	A	4.6	1.1	2.2	1.0
1/4 Hex	10 Nm	88 in-lb	ARTU-25H-10T		A	4.6	1.1	2.2	1.0
1/4 Hex	20 Nm	180 in-lb	ARTU-25H-20T	ARTIS-25H-20T	A	4.6	1.1	2.2	1.0
1/4 Sq.	10 Nm	88 in-lb	ARTU-25S-10T	ARTIS-25S-10T	A	2.9	1.1	2.2	1.0
1/4 Sq.	20 Nm	180 in-lb	ARTU-25S-20T		A	2.9	1.1	2.2	1.0
3/8 Sq.	25 Nm	225 in-lb	ARTU-38S-25T		A	3.0	1.1	2.4	1.2
3/8 Sq.	75 Nm	50 ft-lb	ARTU-38S-75T	ARTIS-38S-75T	A	3.0	1.6	2.7	1.2
1/2 Sq.	180 Nm	130 ft-lb	ARTU-50S-180T	ARTIS-50S-180T	A	3.4	1.6	2.7	1.5
3/4 Sq.	250 Nm	180 ft-lb	ARTU-75S-250T		A	4.1	2.0	3.1	2.2
3/4 Sq.	500 Nm	370 ft-lb	ARTU-75S-500T	ARTIS-75S-500T	A	4.1	2.0	3.1	2.2
1 Sq.	750 Nm	550 ft-lb	ARTU-100S-750T		A	4.9	2.4	3.6	4.0
1 Sq.	1400 Nm	1025 ft-lb	ARTU-100S-1400T	ARTIS-100S-1400T	A	4.9	2.4	3.6	4.0

\*Add this suffix to the end of the part number to indicate torque/angle transducers.

## JOINT KITS

DRIVE SIZE - IN	ROTARY KIT PART NUMBER	STATIONARY KIT PART NUMBER
1/4	AJKR-28	AJKS-25D
3/8	AJKR-135	AJKS-38D
1/2	AJKR-271	AJKS-50D
3/4	AJKR-1017	AJKS-75D
1	AJKR-1695	AJKS-100D

# RUNDOWN FIXTURES / WIRELESS TRANSDUCER



HDS Series

## AUDITOR™ RUNDOWN FIXTURES

AIMCO's ARDIA and ARDFA rundown fixtures provide a cost-effective means to test power tools at various joint rates. We provide three versions of rundown kits: our standard ARDIA or ARDFA, our wear resistant series (HD) and our encapsulated wear resistant series (HDS). Our HDS Series provides wear resistant properties and a sleeve that contains all components preventing nut, bolt and washers from coming apart.



Rundown fixtures for heavy duty use.

MODEL*	DESCRIPTION	RECOMMENDED TORQUE RANGE		SQUARE DRIVE
		in-lb	Nm	in
ARDIA-10(HD)(HDS)	Rundown Fixture	1.0 - 10	.13 - 1.13	1/4
ARDIA-25(HD)(HDS)	Rundown Fixture	2.5 - 25	.28 - 2.8	1/4
ARDIA-100(HD)(HDS)	Rundown Fixture	10.0 - 100	1.3 - 11.3	1/4
ARDIA-250(HD)(HDS)	Rundown Fixture	25.0 - 250	2.8 - 28.25	3/8
ARDIA-500(HD)(HDS)	Rundown Fixture	50.0 - 500	5.6 - 56.5	3/8

\* Add "HD" to part numbers for wear resistant models. Add "HDS" to part numbers for encapsulated wear resistant models.

MODEL*	DESCRIPTION	RECOMMENDED TORQUE RANGE		SQUARE DRIVE
		ft-lb	Nm	in
ARDFA-100(HD)(HDS)	Rundown Fixture	10 - 100	13.6 - 136	1/2
ARDFA-150(HD)(HDS)	Rundown Fixture	15 - 150	20.4 - 204	1/2
ARDFA-250(HD)(HDS)	Rundown Fixture	25 - 250	34.0 - 340	1/2
ARDFA-600(HD)(HDS)	Rundown Fixture	60 - 600	81.6 - 816	3/4

\* Add "HD" to part numbers for wear resistant models. Add "HDS" to part numbers for encapsulated wear resistant models.



## WIRELESS TRANSDUCER SYSTEM – AUDITOR™ ROTATABLE

AIMCO's NEW transducer system – No cables! No bearings! No slip rings! A durable, accurate and cost effective wireless alternative to conventional rotary transducers.

The Auditor Wireless Transducer System can address up to twelve transducers with one instrument. Eight to twelve hour battery life on full charge.

# AUDITOR™ DIGITAL WRENCH SERIES



ADW-0010K11132222



## DATA COLLECTING MODELS

- Large memory capacity.
- Every torque value has associated trace file.
- "Pick a Point" and "Move On" feature.
- Barcode scanner.
- Alpha Numeric screen for entering text.
- Field replaceable batteries.
- Docking station connection.
- Serial connection.
- Battery charger connection.
- Ergonomic handle.
- Switch between measure and data collection modes at any time.
- Multiple files and route capability.
- Data memory and simple statistics "On Board".
- Complete statistical analysis, data archiving and exporting in Audit Manager software.
- Five models standard ranges 10 - 500 Nm full scale.
- Torsion transducer – not length dependent.
- Transducer is replaceable.
- 1400 Nm model uses different handle design.

MODEL*	TORQUE RANGE		WEIGHT		OVERALL LENGTH		SQ. DRIVE
	Nm	ft-lb	lb	kg	in	mm	
ADW-0010K	1-10	0.7-7.4	2.2	1	18	457.2	1/4
ADW-0075K	7.5-75	5.5-55	3.1	1.4	23.5	596.9	3/8
ADW-0180K	18-180	13-130	3.6	1.6	30.1	765.2	1/2
ADW-0270K	27-270	20-198	3.6	1.6	30.1	765.2	3/4
ADW-0500K	50-500	37-369	4	1.8	36	914	1
ADW-1400F	140-1,400	103-1,033	4.8	2.2	60	1524	1

Unit accuracy is  $\pm 1.0\%$  FSD of indicated reading for the top 95% of full scale as indicated above.

Each model includes a case, a battery charger, and a standard square-drive head. Other heads are available at additional cost.

\*Part numbers with K, D or F followed by a 1 designate models with file and route capability. K followed by 2 indicate sequential memory no file capability.

Part numbers with K, D or F followed by a 1,1 indicate file and route with bar code and docking station capability. K, D or F followed by a 1,2 indicate file and route capability with serial port only.

\*\*Please refer to the Wrench Configurator in the Appendix B for required ordering options.



## DOCKING STATION

- Nest for accepting all wrench sizes.
- Charger and serial communication accomplished through docking station.
- Mountable for securing docking station.

# ELECTRONIC TORQUE WRENCHES / ACCESSORIES

## ALLOW PRECISE TIGHTENING AND AUDITING OF YOUR ASSEMBLY APPLICATIONS

### “TRANSDUCERS ON A STICK”

- Non-Length Dependent – Where the operator's hand is positioned during use has no effect on torque readings.
- Available in Industry Standard (IS) or Intelligent (Intellect) Configurations – Transducer is compatible with a wide variety IS style instruments or Auditor™ Intellect instruments that self recognize the transducer.
- Durable – Steel, Aluminum and Carbon Fiber construction providing optimal strength and weight characteristics. Transducer supplied with overload capacity of 150% of full scale.
- Accurate – Torque readings are accurate to 1% of indicated reading in top 95% of full scale.



MODEL	TORQUE RANGE		SQUARE DRIVE in
	Nm	ft-lb	
ATW-0100F	14-136	10-100	3/8
ATW-0200F	27-272	20-200	1/2
ATW-0500F	68-680	50-500	3/4
ATW-1000F	136-1360	100-1000	1

Unit accuracy is ± 0.5% of indicated reading for the top 90% of full scale as indicated above.  
Required Accessory: ATDBRIS IS cable to connect Auditor™ ATDA instrument.

### TORQUE MEASUREMENT ACCESSORIES



ICBL-USB



ATDBLIS

CABLE PART #	DESCRIPTION OF CABLES
RS232C	Serial communication cable Stereo to 9 socket for Auditor
ICBL-USB	Serial communication cable Stereo to USB for Auditor
ATDBLIS	AUET/MTM, ATDA IS w/angle transducer cable – Micro connector to 10 socket transducer connector *(IS)
ATDBRIS	AUET/MTM, ATDA IS transducer cable – Micro connector to 4 socket transducer connector *(IS)
ICBL-10P	AUET/MTM, ATDA Intellect w/angle transducer cable. Identification chip in cable 10 socket connector
ICBL-4P	AUET/MTM, ATDA Intellect transducer cable. Identification chip in cable 4 socket connector
CBL-5000	Micro connector to Military 5 pin connector
ICBL-5000-0	Odu x Odu connector – Old large diameter connector pre 2009
ICBL-5000-L	Lemo x Lemo connector – Current connector for Intellect transducers
ICBL-5000-LO	Lemo x Odu connector for connecting newer instruments to older Intellect transducers – pre 2009
ICBL-5000-LI	Lemo x Lemo Intellect for IS transducers – cable identifies transducer range to instrument.
ICBL-5000-OI	Odu x Odu Intellect for IS transducer cable identifies transducer range to instrument.
ICBL-5000-LA-10	Lemo x Military w/angle for Intellect transducers.
ICBL-5000-LAI-10	Lemo x Military Intellect w/angle for IS w/angle transducers identifies transducer range to instrument.

# AUDITOR™ PRESET TORQUE WRENCHES

## FEATURES AND BENEFITS

- Easy to use preset wrenches for fastener torque auditing.
- Torque ranges from 5-340 Nm.
- User friendly sleek ergonomic design.
- Tactile feedback on achievement of preset torque.
- Proprietary adjustment tool guards against unauthorized setting changes.
- Wide range of interchangeable heads provide user flexibility and convenience.
- +/- 3% accuracy when used in clockwise or counterclockwise directions.



Preset Wrenches	Description
APTW-25	Auditor Preset Torque Wrench, 5-25Nm, Accepts 12mm Inserts
APTW-50	Auditor Preset Torque Wrench, 10-50Nm, Accepts 12mm Inserts
APTW-100	Auditor Preset Torque Wrench, 20-100Nm, Accepts 12mm Inserts
APTW-150	Auditor Preset Torque Wrench, 30-150Nm, Accepts 12mm Inserts
APTW-200	Auditor Preset Torque Wrench, 40-200Nm, Accepts 14mm Inserts
APTW-340	Auditor Preset Torque Wrench, 60-340Nm, Accepts 14mm Inserts

Ratchet and Square Drive Heads	Description
APTH-12RT25	Auditor Preset Torque Wrench Ratchet Insert, 1/4 SQ DR, 12mm
APTH-12RT38	Auditor Preset Torque Wrench Ratchet Insert, 3/8 SQ DR, 12mm
APTH-12RT50	Auditor Preset Torque Wrench Ratchet Insert, 1/2 SQ DR, 12mm
APTH-14RT50	Auditor Preset Torque Wrench Ratchet Insert, 1/2 SQ DR, 14mm
APTH-14RT34	Auditor Preset Torque Wrench Ratchet Insert, 3/4 SQ DR, 14mm
APTH-12SD25	Auditor Preset Torque Wrench SQ DR Insert, 1/4 SQ DR, 12mm
APTH-12SD38	Auditor Preset Torque Wrench SQ DR Insert, 3/8 SQ DR, 12mm
APTH-12SD50	Auditor Preset Torque Wrench SQ DR Insert, 1/2 SQ DR, 12mm
APTH-14SD50	Auditor Preset Torque Wrench SQ DR Insert, 1/2 SQ DR, 14mm



Open End Heads	Description
APTH-120E7	Auditor Preset Torque Wrench Insert 7mm OE, 12mm
APTH-120E8	Auditor Preset Torque Wrench Insert 8mm OE, 12mm
APTH-120E9	Auditor Preset Torque Wrench Insert 9mm OE, 12mm
APTH-120E10	Auditor Preset Torque Wrench Insert 10mm OE, 12mm
APTH-120E11	Auditor Preset Torque Wrench Insert 11mm OE, 12mm
APTH-120E12	Auditor Preset Torque Wrench Insert 12mm OE, 12mm
APTH-120E13	Auditor Preset Torque Wrench Insert 13mm OE, 12mm
APTH-120E14	Auditor Preset Torque Wrench Insert 14mm OE, 12mm
APTH-120E15	Auditor Preset Torque Wrench Insert 15mm OE, 12mm
APTH-120E16	Auditor Preset Torque Wrench Insert 16mm OE, 12mm
APTH-120E17	Auditor Preset Torque Wrench Insert 17mm OE, 12mm
APTH-120E18	Auditor Preset Torque Wrench Insert 18mm OE, 12mm
APTH-120E19	Auditor Preset Torque Wrench Insert 19mm OE, 12mm
APTH-140E13	Auditor Preset Torque Wrench Insert 13mm OE, 14mm
APTH-140E14	Auditor Preset Torque Wrench Insert 14mm OE, 14mm
APTH-140E15	Auditor Preset Torque Wrench Insert 15mm OE, 14mm
APTH-140E16	Auditor Preset Torque Wrench Insert 16mm OE, 14mm
APTH-140E17	Auditor Preset Torque Wrench Insert 17mm OE, 14mm
APTH-140E18	Auditor Preset Torque Wrench Insert 18mm OE, 14mm
APTH-140E19	Auditor Preset Torque Wrench Insert 19mm OE, 14mm
APTH-140E21	Auditor Preset Torque Wrench Insert 21mm OE, 14mm
APTH-140E22	Auditor Preset Torque Wrench Insert 22mm OE, 14mm
APTH-140E24	Auditor Preset Torque Wrench Insert 24mm OE, 14mm
APTH-140E27	Auditor Preset Torque Wrench Insert 27mm OE, 14mm
APTH-140E30	Auditor Preset Torque Wrench Insert 30mm OE, 14mm
APTH-140E32	Auditor Preset Torque Wrench Insert 32mm OE, 14mm
APTH-140E34	Auditor Preset Torque Wrench Insert 34mm OE, 14mm
APTH-140E36	Auditor Preset Torque Wrench Insert 36mm OE, 14mm
APTH-140E38	Auditor Preset Torque Wrench Insert 38mm OE, 14mm
APTH-140E41	Auditor Preset Torque Wrench Insert 41mm OE, 14mm

# AUDITOR™ HIGH-CAPACITY TEST STANDS



AHCTS-500062354122



AHCTS-005K62321122

## AHCTS TEST STANDS FOR ROTATING TOOLS

These test stands are designed for testing tools with continuous rotating output spindles. The test stand includes a rundown fixture, bushing for side load support, reaction post or reaction paddles, transducer and torque analyzer display.

## AHCTS-K STANDS

The AHCTS-K stands are specifically designed for hydraulic wrench testing. Hydraulic wrenches have very low profiles but very high torque output therefore working height must be minimized to prevent side loading which could lead to errors in data or damage to tool or reaction devices.



Either of these stands can be ordered with various options such as extension legs, casters, embedded or attached torque analyzers with various rundown fixtures and reaction devices. Contact an AIMCO Customer Service Associate for additional information, 1-800-852-1368.

MODEL	DESCRIPTION
AHCTS-0500	3/4" Square Drive w/rundown fixture
AHCTS-1000	1" Square Drive w/rundown fixture
AHCTS-2500	1.5" Square Drive w/rundown fixture
AHCTS-5000	1.5" Square Drive w/rundown fixture
AHCTS-7500	1.5" Square Drive w/rundown fixture
AHCTS-5025*	1.5" Sq Dr dual station w/rundown fixture and reaction devices

MODEL	DESCRIPTION
AHCTS-0.5K	3/4" Square Drive w/reaction device
AHCTS-001K	1" Square Drive w/reaction device
AHCTS-2.5K	1.5" Square Drive w/reaction device
AHCTS-005K	1.5" Square Drive w/reaction device
AHCTS-010K	1.5" Square Drive w/reaction device
AHCTS-025K	2" Square Drive w/reaction device

\*This stand has two transducers embedded into the base, one for rotary tools and one for hydraulic tools. It comes with the rundown and reaction fixtures and one display.

\*\*Please refer to the Test Stand Configurator in the Appendix C for required ordering options.

# AUDITOR™ HIGH-CAPACITY TEST STANDS



**AIMTS-0500**  
Test Stand for small impact tools

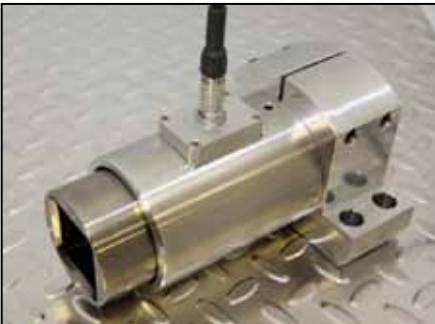

**AIMTS-2000**  
Test Stand for large impact tools



**AHBTS-2500**  
Auto Release Test Stand for quickly testing large rotating tools

## AIMTS STANDS

These test stands are designed to test impact wrenches, it is necessary to bolt them to a bench. We also recommended that a rundown fixture is always used for testing impacts. These test stands are compatible with any Auditor Torque Analyzer.

MODEL	DESCRIPTION
AIMTS-0500	3/4" square drive impact test stand
AIMTS-2000	1.5" square drive impact test stand

## AHBTS STANDS

These test stands are for testing rotating tools without requiring the use of rundown fixtures. We utilize an airbrake for testing tools that cannot or should not be used in reverse. These test stands are compatible with any Auditor Torque Analyzer.

MODEL	DESCRIPTION
AHBTS-2500	1.5" square drive brake system w/reaction device, rotary transducer and display
AHBTS-5000	1.5" square drive brake system w/reaction device, rotary transducer and display

## UHT SERIES TESTERS

- Illustrate tension developed from tools tested
- Will work with virtually any tool, positive clutch, impact, pulse or gear driven tools
- Models with torque ranges from 1-8, 3-20, 20-50, 50- 300, 300-2,000 Nm.

MODEL	DESCRIPTION
UHT-12	Torque Tester, Hydraulic, Cushion/Positive Clutch, 1-8 Nm
UHT-16	Torque Tester, Hydraulic, Impact Clutch, 3-20 Nm
UHT-25	Torque Tester, Hydraulic, 3/8", 20-50 Nm
UHT-35	Torque Tester, Hydraulic, 1/2", 50-300 Nm
UHT-50	Torque Tester, Hydraulic, 3/4" - 1", 300-2,000 Nm



# UFT SERIES JOINT SIMULATORS

## UFT SERIES JOINT SIMULATORS

- AIMCO's UFT Joint Simulators offer the most repeatable and linear joint rate simulation of any product on the market.
- Pulse tool and continuous drive tool certification and testing.
- Consists of a bolt tightening body and a hydraulic pressure loading mechanism. A hydraulic pressure circuit connects these two bodies. Ideal for ISO 5393 test procedures.
- Three joint rates can be easily and quickly simulated by opening or closing two external valves.
- Specially coated testing bolt produces over 100,000 cycles without variation or deformation.
- Self reversing models available late 2012.



**UFT-24**



**UFT-S10**

**UFT-S16**

MODEL	BOLT SIZE	TORQUE RANGE		SNUG TORQUE Nm	A-JOINT RATE Nm/deg	B-JOINT RATE Nm/deg	C-JOINT RATE Nm/deg	D-JOINT RATE Nm/deg	CENTER TO OUTSIDE X HEIGHT mm	WEIGHT	
		ft-lb	Nm							lb	kg
UFT-S10	M6	5 - 11	6.7 - 14.7	2.7	0.36	0.10	0.04	0.02	76 x 203	43	19.5
	M8	11 - 23	14.7 - 31.4	7.5	0.79	0.26	0.06	0.03			
	M10	23 - 40	31.4 - 53.9	14.9	1.22	0.35	0.09	0.06			
UFT-S16	M12	40 - 65	53.9 - 88.2	27.5	1.80	0.51	0.22	0.09	97 x 256	88	40
	M14	65 - 110	88.2 - 149	44.0	2.70	0.79	0.22	0.14			
	M16	110 - 140	149 - 190	73.5	4.70	1.22	0.35	0.21			
UFT-24*	M18	140 - 217	190 - 294						138 x 171	108	49.1
	M20	217 - 325	294 - 441								
	M24	325 - 506	441 - 686								

\* UFT-24 medium hard/soft joints only

Reaction fixture for continuous drive tools not included. Sockets included.



# AUDITOR™ TORQUE CART / TOOLSTRAC

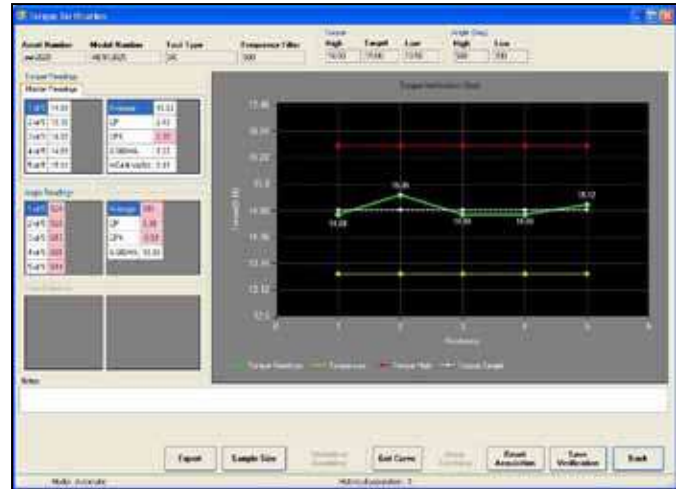

## TORQUE CART

AIMCO offers torque carts for “lineside” or “point of use” tool validation and calibration. Our torque carts allow testing of tools on repeatable joint simulators and “in process” use on production joints, allowing users to identify process capability. There are multiple torque cart options:

- Manual push carts equipped with simple torque testers.
- Manual push carts equipped with data collectors and database application software.
- Self propelled cart with computer and relational database application.
- Driven cart with computer and relational database application.

Each cart can be equipped to specific customer requirements. Maximum torque range on board torque cart is 1000 ft-lb or 1356 Nm. Ancillary test stands up to 50,000 ft-lb available.

## TOOLSTRAC

As the data management system within Auditor™ Torque Carts, ToolsTrac Software is a Total Tool Management, Verification and Calibration application. Users can manage their complete tool inventory with this application. ToolsTrac identifies where the tools are located, calibration and/or service schedule, initial cost as well as total cost of ownership for the life of the tool. The user can compare service, service cost, frequency of repair and accuracy between models and manufacturers of tools with ease.

This application features over 20 embedded reports as well as a Chrystal report editor allowing the user to build their own custom reports or select from pre-configured options. ToolsTrac can be used as a “stand-alone” application, or, using the ToolsTrac Kit, can be part of a bench top testing lab adding torque cart capabilities without the cart! There are no annual user fees or annual license fees for this software! There is nothing on the market that compares with this application – Auditor™ provides the best system at the best value!

# TOOLSTRAC

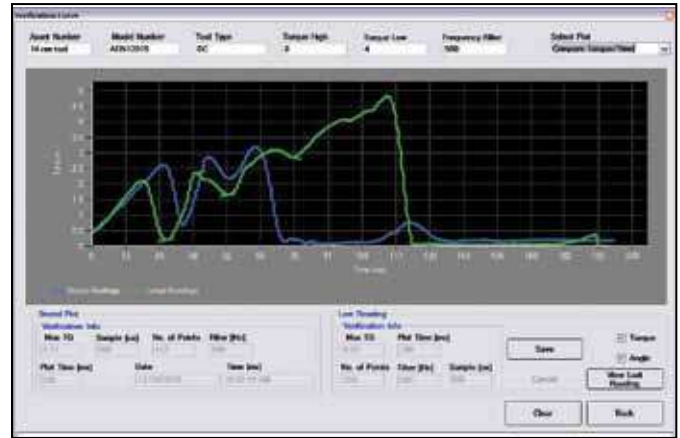
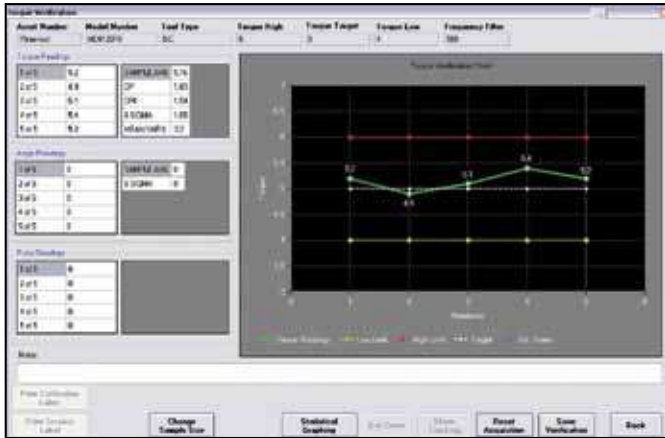

## TORQUE VERIFICATION

ToolsTrac displays sample values of torque, angle and pulse count. It calculates statistics: average, Cp, Cpk, 6 sigma and Mean variation. As values are measured they are graphically plotted on a X-bar range chart scaled to specification limits.

## TRACES

The axis of the traces can be torque/time, torque/angle, angle/time, torque/pulse count, pulse count/time, angle/pulse count. You can save a trace, retrieve it and overlay a new trace for comparison. The trace details are displayed at the bottom of the graph. Maximum values, plot time (ms), number of data points, filter frequency and sample rate.

Operation Name	Critical Operation	Description	Control Type	Joint Type	Torque High	Torque Target	Torque Low	Torque Threshold	Angle High	Angle Low	Angle Threshold
CP Angle	No	angle	Soft		25,000	22,000	19,000	1,500	50	10	
CP Pulse	No	torque	Hard		40,000	38,000	36,000	1,500	100	100	
CP Torque	No	torque	Hard		15,000	12,000	10,000	1,500	10	10	

Asset Number	Manufacturer	Model No	Tool Type	Tool Design	Torque High	Torque Low	Torque Unit	Frequency Filter
ACN0315	Avallone	ACN0315	DC	Angle Head	18,100	2,000	Nm	100

Verification Date	Verification Time	Verified By	Verification Device	Joint Type	Handson Target	Handson Count	Verification Method	Passed Verification
W182018	3:11:52 PM	admin	Torque Cal	Head	5	4	Operation	Yes
W182018	3:28:17 PM	admin	Torque Cal	Head	5	5	Operation	Yes
W182018	3:28:41 PM	admin	Torque Cal	Head	5	5	Operation	Yes

Sample	Master Torque	Statistic	Value	Sample	Master Angle	Statistic	Value	Sample	Master Pulse	Statistic	Value
1	12,880	CP	12.83	1	38	CP	11.95	1	0	CP	83.98
2	12,880	CP	12.83	2	37	CP	11.95	2	0	CP	83.98
3	12,728	6 SIGMA	0.42	3	38	6 SIGMA	3.88	3	0	6 SIGMA	8
4	12,728	6 SIGMA	1.26	4	37	6 SIGMA	3.88	4	0	6 SIGMA	8

Operation Name	Critical Operation	Description	Control Type	Joint Type	Torque High	Torque Target	Torque Low	Torque Threshold	Angle High	Angle Low	Angle Threshold
CP Angle	No	angle	Soft		25,000	22,000	19,000	1,500	50	10	
CP Pulse	No	torque	Hard		40,000	38,000	36,000	1,500	100	100	
CP Torque	No	torque	Hard		15,000	12,000	10,000	1,500	10	10	

Asset Number	Manufacturer	Model No	Tool Type	Tool Design	Torque High	Torque Low	Torque Unit	Frequency Filter
ACN0315	Avallone	ACN0315	DC	Angle Head	18,100	2,000	Nm	100

Verification Date	Verification Time	Verified By	Verification Device	Joint Type	Handson Target	Handson Count	Verification Method	Passed Verification
W182018	3:11:52 PM	admin	Torque Cal	Head	5	4	Operation	Yes
W182018	3:28:17 PM	admin	Torque Cal	Head	5	5	Operation	Yes
W182018	3:28:41 PM	admin	Torque Cal	Head	5	5	Operation	Yes

Sample	Master Torque	Statistic	Value	Sample	Master Angle	Statistic	Value	Sample	Master Pulse	Statistic	Value
1	12,880	CP	12.83	1	38	CP	11.95	1	0	CP	83.98
2	12,880	CP	12.83	2	37	CP	11.95	2	0	CP	83.98
3	12,728	6 SIGMA	0.42	3	38	6 SIGMA	3.88	3	0	6 SIGMA	8
4	12,728	6 SIGMA	1.26	4	37	6 SIGMA	3.88	4	0	6 SIGMA	8

## DATABASE INFORMATION

These screens show Operation lists and associated tools along with the historic test or quality data recorded. From the historic data screen you can launch statistical graphs to view and analyze archived data. The graphs include X-bar range, histogram, sigma, Cp & Cpk graphs.

# APPENDICES

## APPENDIX A: TRANSDUCER CONFIGURATOR

Model Number	Base Model Number (1-11)						
	1	2	3	4	5	6	7
Examples of part numbers	A	I	S	I	-	2	0
	A	I	S	F	-	2	0
	A	X	R	N	-	1	0
Transducer Options and Configuration	Auditor	Configuration	Type	Units		Angle	
		I = Intellect X = Industry Standard	R = Rotary S = Stationary W = Wireless	I = in lb F = ft lb N = NM		1 = Yes 2 = No	

Base model number (first 11 characters) describes Auditor, Configuration Intellect or Industry Standard, Type Rotary, Stationary or Wireless, Engineering Units In Lb, Ft Lb or NM, Angle Yes or No and Capacity.

To complete configuration of a 15 character part number select options and configuration sequentially from column 1 through 15. Columns 7-11 specify torque capacity.

## APPENDIX B: WRENCH CONFIGURATOR

Model Number Columns	Base Model Number (1-9)								
	1	2	3	4	5	6	7	8	9
Examples of part numbers	A	D	W	-	0	0	7	5	K
	A	D	W	-	0	0	1	0	K
	A	T	W	-	0	2	0	0	F
Wrench Options and Configuration	Auditor	Type	Wrench	Capacity					Style
		D = Digital T = Transducer							K = Katana D = Katana w/dovetail transducer F = "Stick" straight handle

Base model number (first 9 characters) describes Auditor, Type; Digital or Transducer, Capacity, Style; Katana, Katana w/Dovetail transducer or Stick.

To complete configuration of a 18 character part number select options and configuration sequentially from column 1 through 18. Columns 5-8 specify torque capacity.

# APPENDICES

8	9	10	11	12	13	14	15
0	0	5	0	1	2	1	2
0	7	5	0	1	2	1	5
0	1	8	0	2	2	2	4
Capacity				Fixture	Expanded Range	Digital Transducer	Drive Size
				1 = Bench Stand 2 = Inline 3 = Loader	1 = Yes 2 = No	1 = Yes 2 = No	1 = 1/4" Hex 2 = 1/4" Sq 3 = 3/8" Sq 4 = 1/2" Sq 5 = 3/4" Sq 6 = 1" Sq 7 = 1-1/2" Sq

The base model number is not a complete part number, - Fixture, Expanded Range, Digital Transducer and Drive Size must be specified by building complete part number.

10	11	12	13	14	15	Future Options (15-18)		
10	11	12	13	14	15	16	17	18
1	1	3	3	1	2	2	2	2
1	1	1	3	2	2	2	2	2
2	2	3	1	2	2	2	2	2
Data Collector	Bar Code Docking Station	Sq Dr	Configuration	Engineering Unit	Angle	Accelerometer	Graphics	Tone Generator
1 = Yes 2 = No	1 = Yes 2 = No	1 = 1/4" 2 = 3/8" 3 = 1/2" 4 = 3/4" 5 = 1" 6 = NA	1 = Intellect (intelligent td) 2 = IS (industry standard) 3 = NA (digitalwrench)	1 = NM 2 = ft lb 3 = in lb	1 = Yes 2 = No	1 = Yes 2 = No	1 = Yes 2 = No	1 = Yes 2 = No
Not yet available so always enter 2 (No) for these options.								

The base model number is not a complete part number, - Data Collector, Bar Code & Docking Station, Sq Dr, Configuration, Engineering Unit and Future Options must be specified by completing 18 character part number.

# APPENDICES

## APPENDIX C: TEST STAND CONFIGURATOR

	Base Model Number (1-10)									
Model Number Columns	1	2	3	4	5	6	7	8	9	10
Example of part numbers	A	H	C	T	S	-	5	0	0	0
	A	H	C	T	S	-	5	0	0	0
	A	H	C	T	S	-	0	0	5	K
	A	H	B	T	S	-	2	0	0	0
Test Stand Configuration and options	Auditor	High	Cap	Test	Stand		Configuration & Capacity K= Hydraulic			

Base model number (first 10 characters) describes Auditor, High, Capacity or Brake, Test Stand, Torque Capacity and Configuration; Rotary or Hydraulic (K).

To complete configuration of a 18 character part number select options and configuration sequentially from column 1 through 18. Columns 7-10 specify torque capacity.

# APPENDICES

11	12	13	14	15	16	17	18
1	3	3	5	7	1	1	2
6	2	3	5	1	1	2	2
1							
4							
Display Options	Legs	Base Dimension	Rundown Fixture Options	Reaction Post Options	Casters	Arm for Display	Digital Module
1 = ATDA	1 = 6" Legs	0 = 8" x 8"	1 = 500 ft lb capacity	1 = 6" Post	1 = Yes	1 = Yes	1 = Yes
2 = No Embedded display	2 = No Legs	1 = 12' x 12"	2 = No rundown fixture	2 = No Post	2 = No	2 = No	2 = No
3 = ATDA-DC	3 = 18" Legs	3 = 14" x 19"	3 = 1000 ft lb capacity	3 = 6" Posts			
4 = ATDA-8000 (7)	4 = Custom Legs in 6" increments	4 = 18" x 24"	4 = 2500 ft lb capacity	4 = Paddles			
5 = ATDA-8000-10 (10)		5 = 18" x 36"	5 = 5000 ft lb capacity	5 = Custom			
6 = Embedded Display		6 = NA no base plate	6 = 7500 ft lb capacity	6 = 9" Post			
7 = ATRC Module			7 = 1.5" rundown kit for "K" stands.	7 = 9" Posts			
			8 = 2.5" rundown kit for "K" stands.				

The base model number is not a complete part number, - Display Options, Legs, Base Dimension, Rundown Fixture, Reaction Post, Casters, Arm and Digital Module must be specified by building complete part number.

# AIMCO PULSE TOOLS: OVERVIEW

## HOW DOES A PULSE TOOL WORK?

The unique design of a pulse tool, combining motor power and hydraulics, leads to an assembly tool that produces smooth, controlled torque in a series of very fast (2 – 4 ms) events and virtually no torque reaction.

- At free-speed, the entire pulse unit, a sealed cylinder containing hydraulic fluid and an output shaft, rotates at the same speed as the tool motor.
- As resistance to rotation increases, the rotation of the output shaft slows, while the rotation of the cylinder and the hydraulic fluid continues until they approach a seal point within the cylinder.
- This seal point produces an increase in fluid pressure and transmits the energy from the rotational mass of the cylinder and fluid to the output shaft, producing torque on the fastener.
- After a series of these cycles (pulses), fluid pressure builds to a point that overcomes the limit of a relief valve, allowing pressure to drop and torque to be controlled.

## BENEFITS OF AIMCO PULSE TOOLS:

*Pulse tools offer advantages in all of the PERQ® elements – productivity, ergonomics, reliability and quality.*

By partnering with AIMCO, manufacturers can apply the advantages of pulse tools in many ways to reduce production costs and increase profits.

- Productivity – Combining high operating speeds with one-handed operation, AIMCO pulse tools help manufacturers produce at the highest possible rates.
- Ergonomics – Light weight, low vibration and no torque reaction make AIMCO pulse tools the safest assembly tools available for threaded assembly.
- Reliability – Advances in design and AIMCO's extensive maintenance and training programs add up to years of low cost service from any AIMCO pulse tool.
- Quality – AIMCO pulse tools offer the most repeatable torque and clamp load results of any assembly tool, guaranteeing high product quality for manufacturers.

## TIMELINE



1965



1980



1988



1995

### NEW TECHNOLOGY

The first pulse tool prototype was designed in an attempt to provide a tool that would provide torque control without the high maintenance costs of impact wrenches.

### U SERIES

Uryu produces the U-series, the first pulse tools to be available commercially for assembly. The U-Series evolves over the next several years to cover torque ranges from 4 – 850 Newton meters and finally, the development of full-shut-off tools. The lack of torque reaction and accurate, repeatable torque makes these tools a manufacturer standard.

### EC SERIES

The EC Series (and later the MC Series) combines the advantages of pulse tools with the technology of controlled tools. By incorporating a transducer into the design of the U-Series pulse tool, customers gain the Productivity and Ergonomics of pulse tools and the traceability and control of other transducerized assembly tools. Manufacturers with safety critical applications now have many more options for assembly tools.

### ALPHA SERIES

The Alpha-series continued Uryu's advancements in pulse-tool design. In order to achieve the best possible power-to-weight ratio, the Alpha 9-blade, twin chamber air motor is developed. Still unique today, this new motor provides significantly more power, thereby, reducing cycle times and improving torque repeatability. The new Alpha air motor and design changes make the tools smaller and lighter, keeping Uryu at the forefront of pulse tool technology.

# OMEGA PULSE TOOLS: UL AND ULT SERIES

## OMEGA UL AND ULT SERIES

The UL and ULT Series stands as the most advanced pulse tool in the world. Whether the goal is improving Productivity, Ergonomics, Reliability or Quality, the UL / ULT Series contains the technology to achieve success.

UL tools, with their non-shut off operation, are ideal for applications where the lightest, fastest tool is necessary. ULT shut off models offer excellent accuracy while allowing the operator to work at the highest possible speed without influencing the tightening process.

- Increases Productivity
- High Power-to-Weight Ratio
- Simple Operation
- Reduced Maintenance
- Extended Service Life
- Environmentally Friendly Design.
- Accurate and Repeatable



Each model features the powerful Alpha air motor and latest in pulse unit design.

- 64 models available from 2.5 – 260 Nm ( 2 – 190 FtLb)
- Models with air, electric, or battery power.
- Available in Standard, Tightening Monitor, and Transducerized versions.

**Size Comparison  
AIMCO 1985-2008**

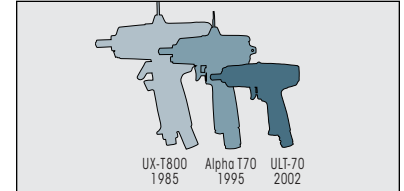

**Weight Comparison  
AIMCO vs. Competition**

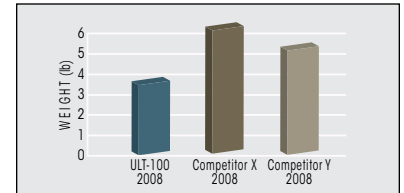

**2001**



**2006**



**2012**



**2013**

### ULT / UL SERIES

Continuous innovations and developments include a new O-ring design that improves durability, roller bearings in the pulse unit to increase hydraulic fluid life and redesigned porting helps maintain fluid temperature and torque repeatability. These changes, combined with even more decreases in tool size and the use of the Alpha air motor, make the UL / ULT Series the tool of choice in major automotive and general industry manufacturers throughout the world.

### UEP-MC SERIES

Uryu does what no other manufacturer can by developing the UEP series, the first and only electric powered pulse tool. The lower speeds, quiet operation, and extremely repeatable torque make the UEP the perfect choice for applications where accuracy and clean operation are critical. By combining programmable tool speed with the MC-style transducer, extremely accurate and repeatable torque is achieved on a variety of applications.

### UDP-MC CONTROLLED SERIES

Uryu introduced the UDP-MC controlled series – smaller, lighter electric pulse tools that have an integrated fan unit. The state-of-the-art UECD controller with a built-in driver box eliminates the need for a secondary driver box in the system configuration.

### UA-AMC CONTROLLED PULSE SERIES

The UA-AMC Series features angle measurement for improved process control. It detects cross threading, double hits on the same fastener, stripped and damaged fastener threads and incorrect fasteners. It also features patented Auto Relief Technology, which modulates the beginning of the torque event, increases pulse frequency, and reduces resistance during the non-pulsing portion of the cycle. This shortens cycle time and increases fluid life.



# OMEGA PULSE TOOLS: UAT SERIES

## PATENTED AUTO RELIEF TECHNOLOGY:

UAT features patented Auto Relief Technology providing additional control to the application of torque during the pulsing events.

- Auto Relief eliminates initial spike of torque during a cycle. Highly effective on hard joint applications.
- Auto Relief ramps up pressure within the pulse unit resulting in more pulses in less time providing a more efficient and even torque event.

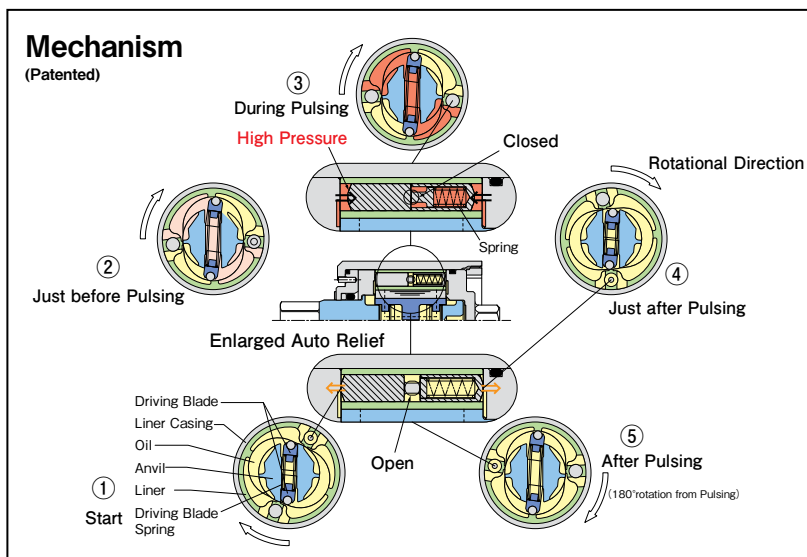

## A NEW LEAP FORWARD IN PRODUCTIVITY AND QUALITY:

- Fastening accuracy and time can be improved by as much as 30% depending on application.

■ Fastening efficiency comparison (UAT vs ULT)

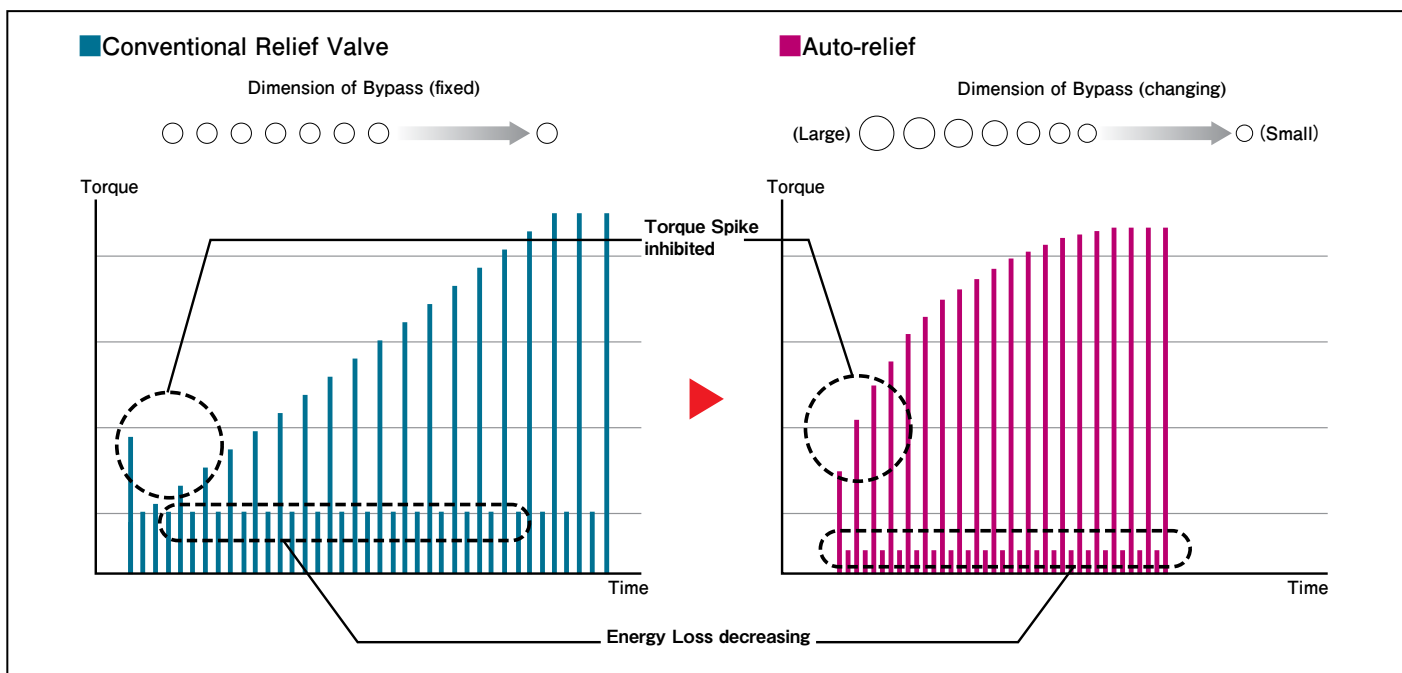
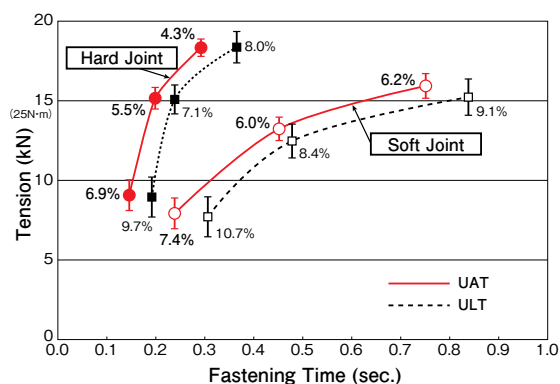

# OMEGA PULSE TOOLS: UAT SERIES



**PISTOL SHUT-OFF**



**INLINE SHUT-OFF**

## PISTOL SHUT-OFF

Recommended Air Pressure: 85 psi

MODEL	FREE SPEED	TORQUE RANGE		WEIGHT		OVERALL LENGTH		DRIVE	SOUND LEVEL	AIR USAGE
	rpm	Nm	ft-lb	lb	kg	in	mm			
UAT-30D	3700	2.5-5.5	1.9-4.1	1.9	.88	6.5	163	1/4	74	7
UAT-40	3800	4.5-8.0	3.5-5.9	2	.92	6.4	162	3/8	75	8.8
UAT-40D	3800	4.5-8.0	3.5-5.9	2	.92	6.4	162	1/4	75	8.8
UAT-50	4600	7.0-15.5	5.2-11.5	2	.92	6.4	162	3/8	78	10.5
UAT-50D	4600	7.0-15.5	5.2-11.5	2	.92	6.4	162	1/4	78	10.5
UAT-50L	4000	7.0-15.5	5.2-11.5	2	.92	6.4	162	3/8	75	8.8
UAT-60	6700	15-32	11.1-23.7	2.1	.95	6.5	174	3/8	80	12.3
UAT-60D	6700	15-32	11.1-23.7	2.1	.95	6.5	174	1/4	80	12.3
UAT-60L	6000	13-28	9.6-20.7	2.1	.95	6.5	174	3/8	77	8.8
UAT-70	6000	30-55	22.2-40.7	2.3	1.05	7.1	180	3/8	80	14
UAT-70L	5300	25-48	18.5-35.5	2.3	1.05	7.1	180	3/8	78	10.5
UAT-80	5600	45-63	33.3-46.6	2.8	1.25	7.3	186	3/8	80	16.8
UAT-90	5700	50-85	37-62.9	3.2	1.45	7.5	192	1/2	82	18.6
UAT-90L	5100	45-75	33.3-55.5	3.2	1.45	7.5	192	1/2	79	15.8
UAT-100	5200	70-130	51.8-96.2	3.7	1.70	7.8	199	1/2	82	19.3
UAT-130	4500	110-150	81.4-111	5.1	2.3	8.5	215	1/2	82	24.7
UAT-200	2400	200-400	147.6-295.2	12.8	5.8	11	279	3/4	85	35.3

Air Hose Size: 1/4" ID for UAT-30 to UAT-50, 3/8" ID for UAT-60 to UAT-100, 1/2" ID for UAT-130 to UAT-200

Note Torque Ranges reflect residual B joint torque values

UAT Models containin "L" indicate models designed to run at 57 PSI air pressure.

All models can be equipped with TM feature for use with qualifier systems. Order TM tools by adding "TM" to model number (for example, UAT-70 becomes UAT-70TM).

Air Inlet Thread: 1/4" NPT for UAT-30 to UAT-100 3/8" NPT for UAT-130 to UAT-200

UAT Models containing "D" indicate 1/4" quick change bit holder

## INLINE SHUT-OFF

Recommended Air Pressure: 85 psi

MODEL	FREE SPEED	TORQUE RANGE		WEIGHT		OVERALL LENGTH		DRIVE	SOUND LEVEL	AIR USAGE
	rpm	Nm	ft-lb	lb	kg	in	mm			
UAT-30SD	3700	2.5-5.5	1.9-4.1	1.6	.75	8.7	221	1/4	68	7
UAT-40S	3300	4.5-8.0	3.3-5.9	1.9	.85	8.8	224	3/8	70	7
UAT-40SD	3300	4.5-8.0	3.3-5.9	1.9	.85	8.8	224	1/4	70	7
UAT-50S	3900	4.5-8.0	5.2-11.5	1.9	.85	8.8	224	3/8	78	8.8
UAT-50SD	3900	4.5-8.0	5.2-11.5	1.9	.85	8.8	224	1/4	78	8.8
UAT-50SL	3800	7-15.5	5.2-11.5	1.9	.85	8.8	224	3/8	75	7
UAT-50SDL	3800	7-15.5	5.2-11.5	1.9	.85	8.8	224	1/4	75	7
UAT-60S	5700	15-32	11.1-23.7	1.9	.87	9	229	3/8	80	10.5
UAT-60SD	5700	15-32	11.1-23.7	1.9	.87	9	229	1/4	80	10.5
UAT-60SL	5300	13-28	9.6-20.7	1.9	.87	9	229	3/8	77	8.8
UAT-60SDL	5300	13-28	9.6-20.7	1.9	.87	9	229	1/4	77	8.8
UAT-70S	4700	30-50	22.2-37	2.1	.95	9.4	239	3/8	80	12.3
UAT-70SL	4400	25.0-45	18.5-33.3	2.1	.95	9.4	239	3/8	78	9.5

Air Hose Size: 1/4" ID for UAT-30 to UAT-50, 3/8" ID for UAT-60 to UAT-70

Note Torque Ranges reflect residual B joint torque values

UAT Models containin "L" indicate models designed to run at 57 PSI air pressure.

All models can be equipped with TM feature for use with qualifier systems. Order TM tools by adding "TM" to model number (for example, UAT-70 becomes UAT-70TM).

Air Inlet Thread: 1/4" NPT for UAT-30 to UAT-70

UAT Models containing "D" indicate 1/4" quick change bit holder

# OMEGA PULSE TOOLS: ULT SERIES



**PISTOL SHUT-OFF**



## PISTOL SHUT-OFF

Recommended Air Pressure: 85 psi

MODEL	FREE SPEED	TORQUE RANGE		WEIGHT		OVERALL LENGTH		DRIVE	SOUND LEVEL	AIR USAGE
	rpm	Nm	ft-lb	lb	kg	in	mm			
ULT-30D	3,700	2.5 - 5.5	1.9 - 4.1	1.9	0.9	-	-	1/4 hex dr.	74	7.0
ULT-30	3,700	2.5 - 5.5	1.9 - 4.1	1.9	0.9	6.4	163	3/8 sq. dr.	74	7.0
ULT-30DL	3,300	2.5 - 5.5	1.9 - 4.1	1.9	0.9	-	-	1/4 hex dr.	74	7.0
ULT-30L	3,300	2.5 - 5.5	1.9 - 4.1	1.9	0.9	6.4	163	3/8 sq. dr.	74	7.0
ULT-40D	3,600	4.5 - 8	3.3 - 5.9	2.0	0.9	6.4	163	1/4 hex dr.	75	7.0
ULT-40	3,600	4.5 - 8	3.3 - 5.9	2.0	0.9	6.3	160	3/8 sq. dr.	75	7.0
ULT-50D	4,400	7 - 15.5	5.2 - 11.5	2.0	0.9	6.4	163	1/4 hex dr.	78	8.8
ULT-50	4,400	7 - 15.5	5.2 - 11.5	2.0	0.9	6.3	160	3/8 sq. dr.	78	8.8
ULT-50DL	4,000	7 - 15.5	5.2 - 11.5	2.0	0.9	6.4	163	1/4 hex dr.	75	7.0
ULT-50L	4,000	7 - 15.5	5.2 - 11.5	2.0	0.9	6.3	160	3/8 sq. dr.	75	7.0
ULT-60D	6,700	15 - 32	11 - 24	2.1	1.0	6.9	175	1/4 hex dr.	80	12.3
ULT-60	6,700	15 - 32	11 - 24	2.1	1.0	6.8	172	3/8 sq. dr.	80	12.3
ULT-60DL	6,000	13 - 28	10 - 21	2.1	1.0	6.9	175	1/4 hex dr.	77	8.8
ULT-60L	6,000	13 - 28	10 - 21	2.1	1.0	6.8	172	3/8 sq. dr.	77	8.8
ULT-70	6,000	30 - 55	22 - 40	2.3	1.1	7.0	178	3/8 sq. dr.	80	14.0
ULT-70L	5,500	25 - 48	19 - 36	2.3	1.1	7.0	178	3/8 sq. dr.	78	10.5
ULT-80	5,900	45 - 63	33 - 47	2.9	1.3	7.3	186	3/8 sq. dr.	80	14.0
ULT-90	5,700	50 - 85	37 - 63	3.2	1.4	7.5	190	1/2 sq. dr.	82	18.6
ULT-90L	5,100	45 - 75	33 - 55	3.2	1.4	7.5	190	1/2 sq. dr.	79	12.8
ULT-100	5,200	70 - 130	52 - 96	3.7	1.7	7.8	197	1/2 sq. dr.	82	19.3
ULT-100L	4,800	60 - 110	44 - 81	3.7	1.7	7.8	197	1/2 sq. dr.	79	16.8
ULT-130	4,500	110 - 150	81 - 111	5.1	2.3	8.5	215	1/2 sq. dr.	82	25.6
ULT-130L	3,600	80 - 125	59 - 93	5.1	2.3	8.5	215	1/2 sq. dr.	79	21.1
ULT-150	3,700	140 - 210	103 - 155	6.4	2.9	9.4	238	3/4 sq. dr.	82	24.5
ULT-150L	3,500	110 - 170	81 - 126	6.4	2.9	9.4	238	3/4 sq. dr.	79	17.5
ULT-180	3,300	170 - 260	126 - 192	8.1	3.7	10.4	262	3/4 sq. dr.	82	24.5
ULT-200	-	280 - 400	207 - 296	9.9	4.5	Under Development				

Air Hose Size: 1/4" I.D. for ULT-30 - ULT-50 - 3/8" I.D. for ULT-60 - ULT-100 - 1/2" I.D. for ULT-150 - ULT-180

Air Inlet: N.P.T. 1/4"

NOTE: Torque ranges reflect residual B joint torque values

\*All pulse tools with "D" include a 1/4" Hex quick-change bit holder. All pulse tools with "" include Tightening Monitored option. All pulse tools with "L", the specifications are based on 57 psi air pressure. Body Jacket included. All models can be equipped with TM feature for use with qualifier systems. Order TM tools by adding "TM" to model number (for example, UAT-70 becomes UAT-70TM).

# OMEGA PULSE TOOLS: ULT SERIES



**INLINE SHUT-OFF**



**RIGHT-ANGLE SHUT-OFF**

## INLINE SHUT-OFF

Recommended Air Pressure: 85 psi

MODEL	FREE SPEED	TORQUE RANGE		WEIGHT		OVERALL LENGTH		DRIVE	SOUND LEVEL	AIR USAGE
	rpm	Nm	ft-lb	lb	kg	in	mm			
ULT-30SD	3,700	2.5 - 5.5	1.9 - 4.1	1.6	0.8	8.7	221	1/4 hex dr.	66	7.0
ULT-40SD	3,600	4.5 - 8	3.3 - 5.9	1.7	0.8	8.7	221	1/4 hex dr.	70	7.0
ULT-40S	3,600	4.5 - 8	3.3 - 5.9	1.7	0.8	8.6	218	3/8 sq. dr.	70	7.0
ULT-50SD	4,700	7.0 - 15.5	5.2 - 11.5	1.8	0.8	8.7	221	1/4 hex dr.	78	8.8
ULT-50S	4,700	7.0 - 15.5	5.2 - 11.5	1.8	0.8	8.6	218	3/8 sq. dr.	78	8.8
ULT-60SD	5,400	15 - 32	11 - 24	1.9	0.8	9.1	232	1/4 hex dr.	80	10.5
ULT-60S	5,400	15 - 32	11 - 24	1.9	0.8	9.0	229	3/8 sq. dr.	80	10.5
ULT-70S	4,700	30 - 50	22 - 37	2.1	1.0	9.4	239	3/8 sq. dr.	80	12.3

Air Hose Size: 1/4 I.D. for ULT-30SD - ULT-50S(D) - 3/8" I.D. for ULT-60S(D) - ULT-70S

Air Inlet: N.P.T. 1/4

NOTE: Torque ranges reflect residual B joint torque values

All pulse tools with "D" include a 1/4" Hex quick-change bit holder.

All models can be equipped with TM feature for use with qualifier systems. Order TM tools by adding "TM" to model number (for example, UAT-70 becomes UAT-70TM).

## RIGHT-ANGLE SHUT-OFF

Recommended Air Pressure: 85 psi

MODEL	FREE SPEED	TORQUE RANGE		WEIGHT		OVERALL LENGTH		SQUARE DRIVE	AIR USAGE
	rpm	Nm	ft-lb	lb	kg	in	mm		
ULT-50C	4,800	7 - 15.5	5.2 - 11.5	3.0	1.35	9.8	250	3/8	8.6
ULT-60C	5,500	15 - 32	11.1 - 23.7	3.2	1.45	10.3	261	3/8	10.5
ULT-70C	4,600	20 - 35	14.8 - 25.9	3.6	1.65	10.8	275	3/8	12.3
ULT-70CH	2,300	30 - 50	22.2 - 37.0	4.1	1.85	11.4	290	1/2	12.3

Air Hose Size: 1/4 I.D. for ULT-50C - 3/8" I.D. for ULT-60C - ULT-70CH

Air Inlet: N.P.T. 1/4

NOTE: Torque ranges reflect residual B joint torque values

All models can be equipped with TM feature for use with qualifier systems. Order TM tools by adding "TM" to model number (for example, UAT-70 becomes UAT-70TM).

# OMEGA PULSE TOOLS: UL SERIES



## Omega Series Pulse Unit

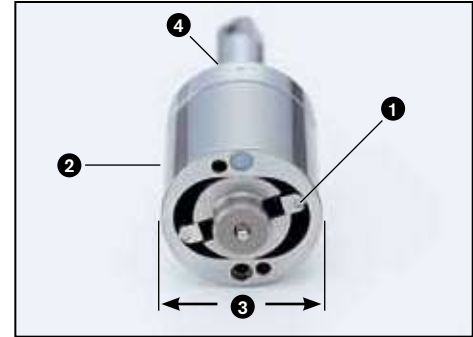

- ❶ Roller bearings – reduced friction.
- ❷ Accumulator – stable fluid temperature.
- ❸ Reduced size – lightweight tools.
- ❹ New O-ring design – better durability.

## PISTOL NON SHUT-OFF

Recommended Air Pressure: 85 psi

MODEL	FREE SPEED	TORQUE RANGE		WEIGHT		OVERALL LENGTH		DRIVE	SOUND LEVEL	AIR USAGE
	rpm	Nm	ft-lb	lb	kg	in	mm			
UL-30D	5,700	6 - 12	4.4 - 8.9	1.5	0.7	5.3	135	1/4 hex dr.	75	7.0
UL-30	5,700	6 - 12	4.4 - 8.9	1.5	0.7	5.2	131	3/8 sq. dr.	75	7.0
UL-40D	6,100	11 - 20	8.1 - 14.8	1.5	0.7	5.5	140	1/4 hex dr.	75	7.0
UL-40	6,100	13 - 22	9.6 - 16.3	1.5	0.7	5.2	131	3/8 sq. dr.	75	7.0
UL-50D	6,400	18 - 28	13.3 - 20.7	1.7	0.8	5.7	144	1/4 hex dr.	78	10.5
UL-50	6,400	22 - 35	16 - 26	1.7	0.8	5.4	137	3/8 sq. dr.	78	10.5
UL-60D	7,000	22 - 35	16 - 26	1.8	0.8	5.7	144	1/4 hex dr.	80	14.0
UL-60	7,000	32 - 50	24 - 37	1.8	0.8	5.4	137	3/8 sq. dr.	80	14.0
UL-70	5,700	40 - 65	30 - 48	2.1	1.0	5.9	149	3/8 sq. dr.	80	15.8
UL-80	5,600	45 - 70	33 - 50	2.5	1.2	6.4	162	3/8 sq. dr.	80	16.8
UL-90	6,000	60 - 100	44 - 74	2.9	1.3	6.6	168	1/2 sq. dr.	82	18.6
UL-100	5,400	80 - 130	59 - 96	3.7	1.7	6.9	175	1/2 sq. dr.	80	20.3
UL-130	4,400	100 - 160	74 - 118	5.1	2.3	7.7	195	1/2 sq. dr.	83	22.7
UL-150	3,800	150 - 230	110 - 313	6.6	3.0	8.4	213	3/4 sq. dr.	-	24.7

## INLINE NON SHUT-OFF

Recommended Air Pressure: 85 psi

MODEL	FREE SPEED	TORQUE RANGE		WEIGHT		OVERALL LENGTH		DRIVE	SOUND LEVEL	AIR USAGE
	rpm	Nm	ft-lb	lb	kg	in	mm			
UL-30SD	5,700	6 - 12	4.4 - 8.9	1.5	0.7	5.2	131	1/4 hex dr.	75	7.0
UL-30S	5,700	6 - 12	4.4 - 8.9	1.5	0.7	5.3	135	3/8 sq. dr.	75	7.0
UL-40SD	6,100	9 - 20	6.7 - 14.8	1.5	0.7	5.2	131	1/4 hex dr.	75	7.0
UL-40S	6,100	11 - 22	8.1 - 16.3	1.5	0.7	5.5	140	3/8 sq. dr.	75	7.0
UL-50SD	6,500	18 - 28	13.3 - 20.6	1.6	0.74	8.4	214	1/4 hex dr.	78	19.3
UL-50S	6,500	22 - 35	16.3 - 25.9	1.6	0.74	8.2	208	3/8 sq. dr.	78	19.3
UL-60SD	7,000	22 - 35	16.3 - 25.9	1.7	0.77	8.3	212	1/4 hex dr.	80	15.8
UL-60S	7,000	32 - 50	23.7 - 37	1.7	0.77	8.2	209	3/8 sq. dr.	80	15.8
UL-70S	5,700	36 - 60	26.6 - 44.4	2.1	1.0	5.9	149	3/8 sq. dr.	80	15.8

Air Hose Size: 1/4 I.D. for UL-30 (D/SD) - UL-50 (D/SD) - 3/8" I.D. for UL-60 (D/SD) - UL-100 (D/SD)  
All pulse tools ending in "D" include a 1/4" Hex quick-change bit holder.

Air Inlet: N.P.T. 1/4

NOTE: Torque ranges reflect residual B joint torque values

# ACRA-PULSE® SERIES



UXR-T3000S



UXR-T1820



UX-T700

## PISTOL SHUT-OFF 3/8" - 1/2" DRIVE

Recommended Air Pressure: 85 psi

MODEL	FREE SPEED	TORQUE RANGE		OVERALL LENGTH		WEIGHT		FROM CENTER TO OUTSIDE		SO. DRIVE	NOISE LEVEL	AIR USAGE
	rpm	Nm	ft-lb	mm	in	lb	kg	mm	in	in	dB(A)	cfm
UX-T700L	7,500	13 - 26	10 - 19	187	7.3	3.2	1.4	25.5	1.0	3/8	72	10.5
UX-T700	7,500	20 - 38	15 - 28	187	7.3	3.2	1.4	25.5	1.0	3/8	72	10.5
UX-T800	8,300	30 - 45	22 - 33	196	7.7	4.0	1.8	28.0	1.1	3/8	75	12.3
UX-T900	7,000	35 - 70	25 - 50	202	7.9	4.4	2.0	30.0	1.2	1/2	75	16.0
UX-T1000	6,800	50 - 90	36 - 65	207	8.1	5.2	2.3	33.0	1.3	1/2	75	17.6
UX-T1300	6,200	70 - 130	50 - 95	225	8.9	6.2	2.8	36.0	1.4	1/2	79	19.4
UX-T1400	5,300	100 - 160	75 - 118	245	9.6	7.5	3.4	40.0	1.6	1/2	79	21.1

Air Hose Size: 3/8" I.D.

Air Inlet: N.P.T. 1/4"

NOTE: Torque ranges reflect residual B joint torque values

All models can be equipped with TM feature for use with qualifier systems. Order TM tools by adding "TM" to model number (for example, UAT-70 becomes UAT-70TM).

## SHUT-OFF 3/4" - 1" DRIVE

Recommended Air Pressure: 85 psi

MODEL	FREE SPEED	TORQUE RANGE		OVERALL LENGTH		WEIGHT		FROM CENTER TO OUTSIDE		SO. DRIVE	NOISE LEVEL	AIR USAGE
	rpm	Nm	ft-lb	mm	in	lb	kg	mm	in	in	dB(A)	cfm
UX-T1620	5,000	120 - 210	87 - 150	260	10.2	8.1	3.7	40	1.6	3/4	82	22.9
UXR-T1820	4,400	150 - 250	110 - 180	270	10.6	9.9	4.5	42	1.6	3/4	84	24.7
UXR-T2000	4,000	200 - 400	150 - 290	303	11.9	15.0	6.8	47	1.8	3/4	85	34.0
UXR-T2400S	3,600	360 - 650	260 - 470	444	17.5	26.4	12.0	62	2.8	1	85	35.2
UXR-T3000S	4,400	450 - 850	330 - 620	477	18.8	32.0	14.5	62	2.8	1	85	37.1

Air Hose Size: 3/8" I.D. for UX-T1620 - 1/2" I.D. for UXR-T1820 - UXR-T3000S

Air Inlet: N.P.T. 3/8" for UXR-T1820 - UXR-T2000 - N.P.T. 1/2" for UXR-T2400S - UXR-T3000S - N.P.T. 1/4" for UX-T1620

NOTE: Torque ranges reflect residual B joint torque values

Inside Trigger Standard (UXR-T2400S - UXR-T3000S)

All models can be equipped with TM feature for use with qualifier systems. Order TM tools by adding "TM" to model number (for example, UAT-70 becomes UAT-70TM).

# ACRA-PULSE® SERIES



## PISTOL NON SHUT-OFF 1/4" HEX DRIVE

Recommended Air Pressure: 85 psi

MODEL	FREE SPEED rpm	TORQUE RANGE		OVERALL LENGTH		WEIGHT		FROM CENTER TO OUTSIDE		NOISE LEVEL dB(A)	AIR USAGE cfm
		Nm	ft-lb	mm	in	lb	kg	mm	in		
U-350D	10,500	3.5 - 5.8	2.5 - 4.2	155	6.1	1.6	0.8	22	0.9	74	5.3
UX-450D	9,500	8 - 14	5.8 - 10	151	5.9	1.9	0.8	22	0.9	65	7.0
UX-500D	9,300	13 - 20	10 - 15	152	6.0	1.9	0.8	22	0.9	70	8.8
UX-612D	9,300	16 - 28	12 - 20	164	6.4	2.1	0.9	23	0.9	75	11.2
UX-700D	9,000	20 - 36	16 - 28	174	6.7	3.0	1.4	26	1.0	72	12.3

Air Hose Size: 1/4 I.D. for U-350D - UX-500D - 3/8" I.D. for UX-612D - UX-700D  
All Tools Standard with 1/4" Quick Change Chuck

Air Inlet Thread: N.P.T. 1/4

NOTE: Torque ranges reflect residual B joint torque values

## PISTOL NON SHUT-OFF 3/8" - 1/2" DRIVE

Recommended Air Pressure: 85 psi

MODEL	FREE SPEED rpm	TORQUE RANGE		OVERALL LENGTH		WEIGHT		FROM CENTER TO OUTSIDE		SQ. DRIVE in	NOISE LEVEL dB(A)	AIR USAGE cfm
		Nm	ft-lb	mm	in	lb	kg	mm	in			
U-410	10,500	7 - 10	5.0 - 7.2	177	7.0	2.2	1.0	22	0.9	3/8	70	5.3
UX-450	9,500	9 - 15	6.5 - 11	148	5.8	1.9	0.8	22	0.9	3/8	65	7.0
UX-500	9,300	15 - 25	11 - 19	148	5.8	1.9	0.8	22	0.9	3/8	70	8.8
UX-612	9,300	20 - 35	15 - 25	160	6.3	2.1	0.9	23	0.9	3/8	75	11.2
UX-700	9,000	25 - 45	20 - 35	169	6.5	3.0	1.4	26	1.0	3/8	73	12.3
UX-800	9,000	35 - 60	25 - 45	176	5.9	3.7	1.7	28	1.1	3/8	73	14.1
UX-900	7,600	45 - 75	35 - 55	181	7.1	4.1	1.9	30	1.2	1/2	75	14.9
UX-1000	6,800	50 - 95	40 - 70	187	7.3	4.8	2.2	33	1.3	1/2	75	17.9
UX-1300	6,200	80 - 130	60 - 95	205	8.1	5.9	2.7	36	1.4	1/2	76	19.4
UX-1400	5,300	100 - 160	75 - 118	224	8.7	7.0	3.2	40	1.6	1/2	78	21.1
ALPHA-130	3,400	100 - 160	73 - 118	209	8.2	5.8	2.6	36	1.4	1/2	82	22.9

Air Hose Size: 1/4 I.D. for U-410 - UX-500 - 3/8" I.D. for UX-612 - UX-1400; ALPHA-130

Air Inlet: N.P.T. 1/4

NOTE: Torque ranges reflect residual B joint torque values

## PISTOL NON SHUT-OFF 3/4" - 1" DRIVE

Recommended Air Pressure: 85 psi

MODEL	FREE SPEED rpm	TORQUE RANGE		OVERALL LENGTH		WEIGHT		FROM CENTER TO OUTSIDE		SQ. DRIVE in	NOISE LEVEL dB(A)	AIR USAGE cfm
		Nm	ft-lb	mm	in	lb	kg	mm	in			
ALPHA-140	3,100	150 - 230	110 - 169	226	8.9	7.4	3.3	40	1.6	3/4	84	24.7
ALPHA-160	3,700	160 - 270	118 - 198	245	9.6	8.4	3.8	40	1.6	3/4	84	31.7
ALPHA-180	3,500	270 - 350	198 - 258	250	9.8	10.1	4.6	42	1.7	3/4	85	33.6
UX-1620	5,000	120 - 190	90 - 140	241	9.5	7.9	3.6	40	1.6	3/4	82	22.9
UXR-1820	4,600	160 - 250	118 - 185	242	9.5	9.0	4.1	42	1.6	3/4	84	26.3
UXR-2000	4,200	300 - 450	220 - 330	280	11.0	15.0	6.8	47	1.8	3/4	85	31.5
UXR-2000S	4,200	300 - 450	220 - 330	340	13.4	15.4	7.0	47	1.8	3/4	85	31.6
UXR-2400S	4,000	400 - 650	290 - 470	385	15.2	23.7	10.8	55	2.1	1	85	35.2
UXR-3000S	4,400	500 - 850	360 - 630	455	16.6	29.3	13.3	62	2.8	1	85	37.1

Air Hose Size: 3/8 I.D. for UX-1620, ALPHA-140 - ALPHA-160 - 1/2" I.D. for UXR-1820 - UXR-3000S, ALPHA-180

Air Inlet: N.P.T. 1/4 for UX-1620 N.P.T. 3/8 for UXR-1820, UXR-2000(S), Alpha-180 N.P.T. 1/2 for UXR-2400S - UXR-3000S

NOTE: Torque ranges reflect residual B joint torque values Torque Control in Left-Hand Rotation Available (UXR-2000 - UXR-3000S) Inside Trigger Standard (UXR-2000S - UXR-3000S)

# ACRA-PULSE® SERIES



UX-ST1000



## AUTO REVERSING

Recommended Air Pressure: 85 psi

MODEL	FREE SPEED rpm	TORQUE RANGE		OVERALL LENGTH		WEIGHT		FROM CENTER TO OUTSIDE		NOISE LEVEL dB(A)	AIR USAGE cfm
		Nm	ft-lb	mm	in	lb	kg	mm	in		
UX-ST800	7,300	35 - 55	25 - 40	195	7.7	3.8	1.7	28	1.1	75	10.5
UX-ST1000	6,300	50 - 90	40 - 65	210	8.3	5.5	2.5	33	1.3	75	16.8

Air Hose Size: 3/8 I.D.

Air Inlet: N.P.T. 1/4

NOTE: Torque ranges reflect residual B joint torque values

## INLINE NON SHUT-OFF 1/4" HEX DRIVE

Recommended Air Pressure: 85 psi

MODEL	FREE SPEED rpm	TORQUE RANGE		OVERALL LENGTH		WEIGHT		FROM CENTER TO OUTSIDE		NOISE LEVEL dB(A)	AIR USAGE cfm
		Nm	ft-lb	mm	in	lb	kg	mm	in		
U-310SD	11,000	2.5 - 3.1	1.8 - 2.2	222	8.7	1.5	0.6	18	0.7	74	5.3
U-350SD	10,500	3.5 - 5.8	2.5 - 4.2	238	9.4	1.5	0.6	22	0.9	74	5.3
U-410SD	10,500	7 - 10	5 - 7.2	240	9.4	1.8	0.8	22	0.9	69	5.3
UX-450SD	9,500	8 - 14	5.8 - 10	239	9.4	1.8	0.8	22	0.9	69	7.0
UX-500SD	9,300	13 - 20	10 - 15	244	9.6	2.0	0.9	22	0.9	70	8.8
UX-612SD	9,300	16 - 28	12 - 20	253	9.9	2.2	1.0	23	0.9	75	11.1
UX-700SD	9,000	20 - 36	16 - 28	249	9.8	2.8	1.3	27	1.0	78	12.3

Air Hose Size: 1/4 I.D. for U-310SD - UX-500SD - 3/8" I.D. for UX-612SD - UX-700SD Air Inlet: N.P.T. 1/4"  
All Tools Standard with 1/4 Quick Change Chuck

NOTE: Torque ranges reflect residual B joint torque values

## INLINE NON SHUT-OFF 3/8" - 1/2" DRIVE

Recommended Air Pressure: 85 psi

MODEL	FREE SPEED rpm	TORQUE RANGE		OVERALL LENGTH		WEIGHT		FROM CENTER TO OUTSIDE		SQ. DRIVE in	NOISE LEVEL dB(A)	AIR USAGE cfm
		Nm	ft-lb	mm	in	lb	kg	mm	in			
U-410S	10,500	7 - 10	5.0 - 7.2	239	9.4	1.8	0.8	22	0.9	3/8	70	5.3
UX-450S	9,500	9 - 15	6.5 - 11	233	9.2	1.8	0.8	22	0.9	3/8	67	7.0
UX-500S	9,300	15 - 25	11 - 19	239	9.4	2.0	0.9	22	0.9	3/8	70	8.8
UX-612S	9,300	20 - 35	15 - 25	248	9.8	2.2	1.0	23	0.9	3/8	75	11.1
UX-700S	9,000	25 - 45	20 - 35	244	9.6	2.8	1.3	27	1.0	3/8	78	12.3
UX-800S	9,000	35 - 60	25 - 45	250	9.8	3.2	1.5	36	1.4	3/8	75	14.2
UX-900S	7,600	45 - 75	35 - 55	310	12.2	3.9	1.8	38	1.4	1/2	75	14.9
UX-1000S	6,800	50 - 95	40 - 70	320	12.6	4.6	2.1	39	1.4	1/2	75	17.6
UX-1300S	6,200	80 - 130	60 - 95	336	13.2	6.6	2.5	42	1.3	1/2	79	19.4

Air Hose Size: 1/4 I.D. for U-410S - UX-500S - 3/8" I.D. for UX-612S - UX-1300S

Air Inlet: N.P.T. 1/4

NOTE: Torque ranges reflect residual B joint torque values

## ANGLE 3/8" - 1/2" DRIVE

Recommended Air Pressure: 85 psi

MODEL	FREE SPEED rpm	TORQUE RANGE		WEIGHT		OVERALL LENGTH		SQ. DRIVE in	NOISE LEVEL dB(A)	AIR USAGE cfm
		Nm	ft-lb	lb	kg	mm	in			
ALPHA-70C	6,300	25 - 40	18 - 29	3.9	1.8	266	10.5	3/8	82	15.8
ALPHA-70CH	3,600	50 - 76	36 - 56	4.4	2.0	282	11.1	1/2	82	15.8
UX-500C	9,300	13 - 20	10 - 15	2.8	1.3	270	10.6	3/8	82	8.8
UX-612C	9,800	16 - 28	12 - 20	3.0	1.4	283	11.1	3/8	85	11.2
UX-700C	9,500	20 - 36	16 - 28	3.7	1.7	275	10.8	3/8	85	12.3
UX-800C	9,000	29 - 43	20 - 31	4.3	1.9	285	11.2	3/8	85	14.1
UX-900C	7,600	35 - 55	25 - 40	5.0	2.2	338	13.3	3/8	90	14.9
UX-1000C	6,800	50 - 80	40 - 58	6.8	3.1	365	14.3	1/2	90	17.9
UX-612A	9,800	16 - 28	12 - 20	3.0	1.4	297	11.7	3/8	85	10.5

Air Hose Size: 1/4 I.D. for UX-500C - 3/8" I.D. for ALPHA-70C, ALPHA-70CH, UX-612C - UX-1000C

Air Inlet: N.P.T. 1/4

NOTE: Torque ranges reflect residual B joint torque values



# UDBP PULSE SERIES CORDLESS TOOLS

**The next generation of the cordless pulse tool!**

**Combines industry-leading pulse technology with Lithium-Ion battery power.**

## FEATURES AND BENEFITS

- Uryu Direct Battery Pulse (UDBP) – This new design connects the pulse unit directly to the motor, no reduction gearing; resulting in a tool with less noise and vibration.
- The new brushless Internal Permanent Magnet (IPM) motor provides longer motor life and more efficiency allowing more fastening cycles per battery charge.
- UDBP features patented Auto Relief Technology providing additional control to the application of torque during the pulsing events.
- On board LED's for application illumination.
- Li-Ion battery provides more power and ends the "battery-memory" issues of NiCd batteries.
- Tool / battery combination is 27% lighter than earlier UBP tools.
- RF Types transmit "good" signal to receiver (sold separately) over 426Mhz.
- "Good" signal can be used for Poka-Yoke or Bolt Counting.



**Battery: UB111Li, UB222Li, UB333Li  
UB333Li**

The lithium-ion battery provides better power-to-weight ratio. It will not be affected by the memory effect caused by the repeated recharging after being only partially discharged.

The battery power indicator provides you with a visual indication to charge the lithium-ion battery.

- = good charge
- = low charge (recharging needed)
- = very low charge (immediate recharging needed)

The slide design battery provides the high-energy efficiency in power and no damage to contact.



**Charger: UBC**

(P) represents the 3/8" square drive anvil with socket retainer pin. (RF) represents the tool with wireless transmission feature.

MODEL	TYPE	FREE SPEED	TORQUE RANGE		WEIGHT	LENGTH	DRIVE	SOUND LEVEL	VOLTAGE	BATTERY	CHARGER
		rpm	Nm	ft-lb	(w/battery) lb	in	in	dB(A)	V		
UDBP-T40	Shut-off	4800	4.5-8	3.3-5.9	3.08	8.18	1/4 Hex	75	11.1	UB111Li	UBC
UDBP-T40(RF)	Shut-off	4800	4.5-8	3.3-5.9	3.08	8.18	1/4 Hex	75	11.1	UB111Li	UBC
UDBP-T50	Shut-off	4800	6.5-13	4.8-9.6	3.08	8.18	1/4 Hex	76	11.1	UB111Li	UBC
UDBP-T50(RF)	Shut-off	4800	6.5-13	4.8-9.6	3.08	8.18	1/4 Hex	76	11.1	UB111Li	UBC
UDBP-T60	Shut-off	4800	15-28	11.1-20.7	3.74	8.83	1/4 Hex	76	22.2	UB222Li	UBC
UDBP-T60(RF)	Shut-off	4800	15-28	11.1-20.7	3.74	8.83	1/4 Hex	76	22.2	UB222Li	UBC
UDBP-T50(P)	Shut-off	4800	7-15	5.1-11.1	3.08	8.07	3/8 Sq.	76	11.1	UB111Li	UBC
UDBP-T50(P)(RF)	Shut-off	4800	7-15	5.1-11.1	3.08	8.07	3/8 Sq.	76	11.1	UB111Li	UBC
UDBP-T60(P)	Shut-off	4800	15-28	11.1-20.7	3.74	8.83	3/8 Sq.	76	22.2	UB222Li	UBC
UDBP-T60(P)(RF)	Shut-off	4800	15-28	11.1-20.7	3.74	8.83	3/8 Sq.	76	22.2	UB222Li	UBC
UDBP-T70P	Shut-off	4800	26-47	19.2-34.7	4.41	9.21	3/8 Sq.	76	33.3	UB333Li	UBC

Adding "KIT" to the tool model number will include two (2) batteries and the battery charger with the specified tool. Example: UDBP-T50KIT

Battery: UB111Li, UB222Li, UB333Li (also sold separately)

NOTE: Torque ranges reflect residual B joint torque values.

Charger: UBC (also sold separately)

Charge Time: 80% battery capacity - 40 minutes, 100% battery capacity - 64 minutes



MODEL	DESCRIPTION
TWF-600R	Receiver for UDBP (RF) type tools 426Mhz (also sold separately)

# NUTRUNNERS: OVERVIEW

## UAN SERIES ANGLE NUTRUNNERS

- Torque Control
- Electronically Monitored or Controlled Type

Designed for fastening in tight quarters or applications not served well by a pulse tool. The UAN Series transfers torque through beveled angle gears, continuously driving the fastener. When the resistance to rotation overcomes the spring resistance on the clutch, the tool will disengage at the adjusted torque value. Low reaction force characteristics on hard joints make it comfortable for the operator to use. Ideal for applications ranging from 6-60 Nm (4 – 44 ft-lbs).

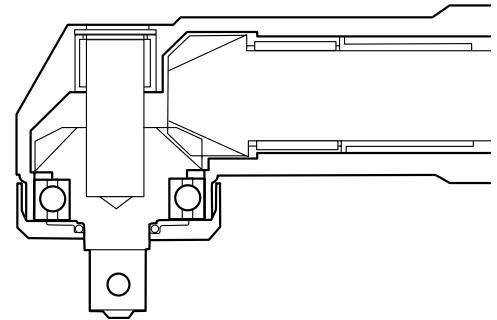

## URW SERIES IN-LINE RATCHET WRENCHES

Designed to set flush over the fastener head, the URW Series is ideal for narrow fastening spaces. Motor torque is transferred from a gear driven, dual lobed cam that pushes a spring loaded push rod, rotating the socket one tooth at a time. A wide variety of socket sizes, head thicknesses, and tool lengths allow the URW Series access to many difficult applications.

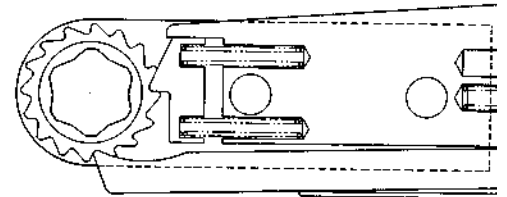

## UOW SERIES OPEN-END NUTRUNNERS

Designed for tubenut fastening, the UOW Series can transfer torque through a variety of options.

- Stall Type – Depending on the application requirements, the standard UOW Series will stall when torque resistance matches power output.
- Mechanical Shut-off Type – For greater torque accuracy and less reaction impulse to the operator, the UOW-T Series incorporates a mechanical clutch to shut off the tool at the preset torque.
- Electronically Monitored Type – For critical torque applications requiring monitoring or controlling of the fastening torque, the UOW-M Series utilizes a transducer to signal the clutch shut-off.
- UOW series incorporates a one-hand, two-step throttle, which automatically reverses the socket to a preset open position.

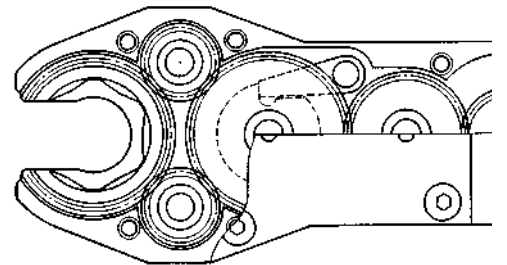

# NUTRUNNERS



## ANGLE TORQUE CONTROL UAN SERIES

Recommended Air Pressure: 85 psi

MODEL	TORQUE RANGE		FREE SPEED rpm	OVERALL LENGTH		ANGLE HEAD HEIGHT		FROM CENTER TO OUTSIDE		WEIGHT LESS SOCKET		SQUARE DRIVE LEVEL in	NOISE LEVEL dB(A)	AIR USAGE cfm
	Nm	ft-lb		mm	in	mm	in	mm	in	kg	lb			
UAN-611R-60C	6.5 - 12.0	4.3 - 8.6	620	383	15.1	47.0	1.9	14.0	0.6	1.6	3.5	3/8	80	21.2
UAN-611R-50C	8.5 - 15.0	5.7 - 10.8	470	373	14.7	47.0	1.9	14.0	0.6	1.6	3.5	3/8	80	21.2
UAN-611R-40C	10.0 - 18.0	7.2 - 12.9	400	373	14.7	47.0	1.9	14.0	0.6	1.6	3.5	3/8	80	21.2
UAN-611R-30C	13.0 - 25.0	9.3 - 18.0	270	373	14.7	47.0	1.9	14.0	0.6	1.6	3.5	3/8	80	21.2
UAN-701R-60C	20.0 - 31.0	14.8 - 22.8	600	445	17.5	47.0	1.9	14.0	0.6	2.4	5.3	3/8	85	31.8
UAN-701R-40C	28.0 - 45.0	20.7 - 33.2	400	455	17.9	51.0	2.0	18.0	0.7	2.4	5.3	3/8	85	31.8
UAN-701R-30C	37.0 - 60.0	27.3 - 44.2	300	455	17.9	60.5	2.4	18.0	0.7	2.4	5.3	1/2	85	31.8

Air Hose Size: 3/8 I.D.

Air Inlet: N.P.T. 1/4

## INLINE TORQUE CONTROL UAN SERIES

Recommended Air Pressure: 85 psi

MODEL	TORQUE RANGE		FREE SPEED rpm	OVERALL LENGTH		FROM CENTER TO OUTSIDE		WEIGHT LESS SOCKET		SQUARE DRIVE LEVEL in	NOISE LEVEL dB(A)	AIR USAGE cfm
	Nm	ft-lb		mm	in	mm	in	kg	lb			
UAN-611RS-60C	4 - 8		960	322	12.7	40	1.6	1.3	2.9	3/8	80	21.2
UAN-611RS-50C	6.5 - 10		740	322	12.7	40	1.6	1.3	2.9	3/8	80	21.2
UAN-611RS-40C	6.5 - 12		600	322	12.7	40	1.6	1.3	2.9	3/8	80	21.2
UAN-611RS-30C	8.5 - 16		420	322	12.7	40	1.6	1.3	2.9	3/8	80	21.2
UAN-701RS-60C	13 - 21		900	396	15.6	45	1.8	1.9	4.2	3/8	85	31.8
UAN-701RS-40C	20 - 30		620	396	15.6	45	1.8	1.9	4.2	3/8	85	31.8
UAN-701RS-30C	25 - 40		430	396	15.6	45	1.8	1.9	4.2	3/8	85	31.8

Air Hose Size: 3/8 I.D.

Air Inlet: N.P.T. 1/4

## ANGLE TRANSDUCERIZED TORQUE CONTROL UAN SERIES

Recommended Air Pressure: 85 psi

MODEL	TORQUE RANGE		FREE SPEED rpm	OVERALL LENGTH		ANGLE HEAD HEIGHT		FROM CENTER TO OUTSIDE		WEIGHT LESS SOCKET		SQUARE DRIVE LEVEL in	NOISE LEVEL dB(A)	AIR USAGE cfm
	Nm	ft-lb		mm	in	mm	in	mm	in	kg	lb			
UAN-611RM-60C	6.5 - 12.0	4.3 - 8.6	620	419	16.5	47.0	1.9	14.0	0.6	2.0	4.4	3/8	80	21.2
UAN-611RM-50C	8.5 - 15.0	5.7 - 10.8	470	409	16.1	47.0	1.9	14.0	0.6	2.0	4.4	3/8	80	21.2
UAN-611RM-40C	10.0 - 18.0	7.2 - 12.9	400	409	16.1	47.0	1.9	14.0	0.6	2.0	4.4	3/8	80	21.2
UAN-611RM-30C	13.0 - 25.0	9.3 - 18.0	270	409	16.1	47.0	1.9	14.0	0.6	2.0	4.4	3/8	80	21.2
UAN-701RM-60C	20.0 - 31.0	14.8 - 22.8	600	480	18.9	47.0	1.9	14.0	0.6	2.7	5.9	3/8	85	31.8
UAN-701RM-40C	28.0 - 45.0	20.7 - 33.2	400	492	19.4	51.0	2.0	18.0	0.7	2.9	6.4	3/8	85	31.8
UAN-701RM-30C	37.0 - 60.0	27.3 - 44.2	300	492	19.4	60.5	2.4	18.0	0.7	2.9	6.4	1/2	85	31.8

Air Hose Size: 3/8 I.D.

Air Inlet: N.P.T. 1/4

# NUTRUNNERS



## UOW/UOW-T SERIES

Recommended Air Pressure: 85 psi

MODEL	MAX TORQUE / RANGE		FREE SPEED rpm	OVERALL LENGTH		WEIGHT		MIN/MAX HEX SOCKET SIZE		NOISE LEVEL dB(A)	AIR USAGE cfm
	Nm	ft-lb		mm	in	lb	kg	mm	in		
<b>STALL</b>											
UOW-11-10	12.7	9.4	400	295	11.7	3.1	1.4	7 - 12	1/4 - 7/16	75	12.5
UOW-11-14	15.7	11.6	260	311	12.2	4.0	1.8	10 - 17	3/8 - 5/8	75	12.5
UOW-11-22	23.5	17.4	180	326	12.8	4.0	1.8	13 - 24	1/2 - 7/8	75	12.5
UOW-11-30	31.4	23.1	135	347	13.6	5.5	2.5	17 - 32	5/8 - 1-3/16	75	12.5
<b>SHUT-OFF CLUTCH</b>											
UOW-T60-10	3.9 - 12.7	2.9 - 9.4	300	370	14.6	4.0	1.8	7 - 12	1/4 - 7/16	75	18.0
UOW-T60-14	4.9 - 16.7	3.6 - 12.3	230	385	15.1	4.8	2.2	10 - 17	3/8 - 5/8	75	18.0
UOW-T60-22	6.9 - 23.5	5.1 - 17.4	170	400	15.7	4.8	2.2	13 - 24	1/2 - 7/8	75	18.0
UOW-T60-30	9.8 - 31.4	7.2 - 23.1	130	422	16.6	6.4	2.9	17 - 32	5/8 - 1-3/16	75	18.0
<b>GEARED WRENCHES</b>											
UGW-6N	18	13.3	530	310	12.2	3.1	1.4	9 - 11	3/8 - 7/16	76	22.0
UGW-8N	23	17.0	410	322	12.7	3.3	1.5	12 - 14	3/8 - 5/8	76	22.0



## URW SERIES

Recommended Air Pressure: 85 psi

MODEL	MAX TORQUE		FREE SPEED rpm	OVERALL LENGTH		WEIGHT		MIN/MAX HEX SOCKET SIZE		AIR USAGE cfm
	Nm	ft-lb		mm	in	lb	kg	mm	in	
<b>STRAIGHT HEAD</b>										
URW-6	10.8	7.9	200	292	11.5	2.5	1.1	5.5 - 12	1/4 - 7/16	9.9
URW-8N	15.7	11.6	220	300	11.8	4.0	1.8	6 - 15	1/4 - 9/16	19.5
URW-8	13.7	10.1	240	360	14.2	4.0	1.8	6 - 15	1/4 - 9/16	19.5
URW-9N	31.4	23.1	200	380	15.0	5.0	2.3	6 - 15	1/4 - 9/16	23.7
URW-10N	56.8	41.9	150	394	15.5	5.8	2.6	10 - 19	3/8 - 3/4	25.0
URW-10N-1	56.8	42.0	150	417	16.4	5.7	2.5	10 - 15	3/8 - 9/16	29.0
URW-12N	58.8	43.4	150	397	15.6	5.9	2.7	12 - 22	5/16 - 7/8	25.0
URW-12NA	78.4	57.8	100	408	16.1	6.6	3.0	16 - 30	7/16 - 1	25.0
URW-12NB	93.1	68.7	85	416	16.3	7.0	3.2	14 - 33	1/2 - 1-15/16	25.0
<b>BENT HEAD</b>										
URW-60R	10.8	7.9	200	288	11.3	2.5	1.1	5.5 - 12	1/4 - 7/16	9.9
URW-60	10.8	7.9	200	288	11.3	2.5	1.1	5.5 - 12	1/4 - 7/16	9.9
URW-80R	15.7	11.6	220	300	11.9	4.0	1.8	6 - 15	1/4 - 9/16	19.5
URW-80	15.7	11.6	220	300	11.9	4.0	1.8	6 - 15	1/4 - 9/16	19.5
URW-81R	15.7	11.6	220	300	11.9	4.0	1.8	6 - 15	1/4 - 9/16	19.5

# SCREWDRIVERS: OVERVIEW

## TORQUE CONTROL AUTOMATIC SHUT-OFF TYPE

- Precise repeatability improves quality.
- Minimal wear on internal parts for longer life.
- Quick shut off for minimum torque reaction.
- Speed choice for flexibility.
- Easy external torque adjustment.
- Midrange air motor provides high speed during entire cycle.
- Ideal for industrial torque control applications.



## CUSHION CLUTCH TYPE

- Good general duty screwdriver.
- High speed rundown.
- Clutch ratchets at preset torque.
- Internal torque adjustment.
- General assembly, wood, and sheet metal screws.

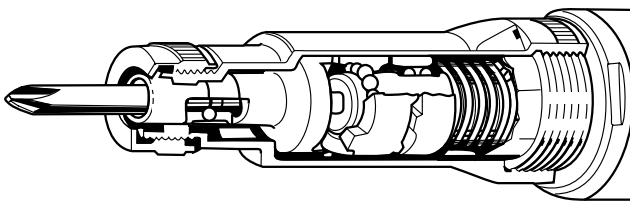

## POSITIVE CLUTCH TYPE

- Good for varying torque applications.
- Clutch ratchets at preset torque.
- Operator can force clutch engagement for higher torque.
- Good for prevailing torque applications.

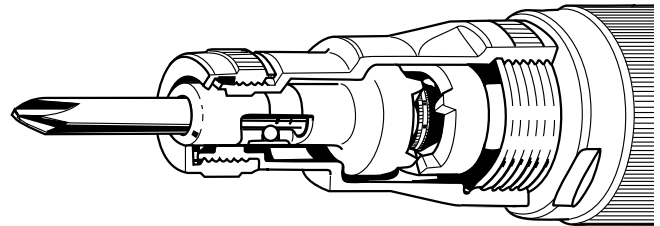

## IMPACT TYPE

- High power-to-weight ratio.
- Fast cycle times with free speeds up to 16,000 rpm.
- Ideal for non-critical applications.

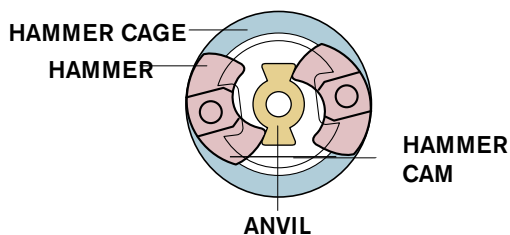

## DIRECT DRIVE

- Air motor driven gears.
- Stall torque dependent on air pressure.
- Simple maintenance.
- Lightest and smallest air screwdriver.
- Ideal for soft draw applications such as wood screws, self tapping screws, or trim screws.

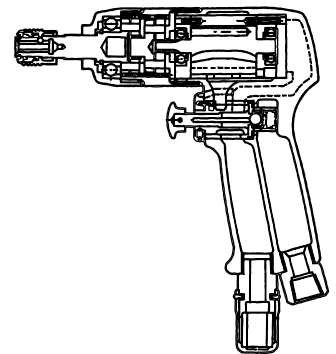

# PNEUMATIC SCREWDRIVERS

## TORQUE CONTROL LIGHT TOUCH (LT) SERIES - PUSH-TO-START INLINE

Recommended Air Pressure: 85 psi  
Each model is equipped with its standard and alternate clutch springs.

MODEL	TORQUE RANGE		FREE SPEED rpm	OVERALL LENGTH		WEIGHT		FROM CENTER TO OUTSIDE		NOISE LEVEL dB(A)	AIR USAGE cfm
	Nm	in-lb		mm	in	lb	kg	mm	in		
US-LT10B	0.20 - 0.60	1.8 - 5.3	1,000	190	7.5	0.6	0.3	12	0.5	75	5.2
US-LT20B-10	0.15 - 1.10	1.3 - 9.7	1,000	180	7.1	0.7	0.3	13	0.5	70	5.6
US-LT20B-18	0.15 - 0.70	1.3 - 6.2	1,800	180	7.1	0.7	0.3	13	0.5	70	5.6
US-LT20B-26	0.15 - 0.35	1.3 - 3.1	2,600	180	7.1	0.7	0.3	13	0.5	70	5.6
US-LT30B-11	0.40 - 2.10	3.5 - 18.5	1,100	187	7.2	0.9	0.4	16	0.6	70	7.0
US-LT30B-17	0.40 - 1.50	3.5 - 13.0	1,700	187	7.2	0.9	0.4	16	0.6	70	7.0
US-LT30B-23	0.40 - 1.00	3.5 - 8.7	2,300	187	7.2	0.9	0.4	16	0.6	71	7.0
US-LT40B-08	1.00 - 4.00	8.7 - 34.7	800	209	8.2	1.4	0.6	17	0.6	70	10.5
US-LT40B-15	1.00 - 2.20	8.7 - 19.1	1,500	209	8.2	1.4	0.6	17	0.6	70	10.5
US-LT40B-21	1.00 - 1.70	8.7 - 14.8	2,100	209	8.2	1.4	0.6	17	0.6	74	10.5
US-LT50B-05	1.50 - 10.50	13.2 - 92.4	480	240	9.4	2.2	1.0	20	0.8	74	17.5
US-LT50B-08	1.50 - 5.50	13.2 - 48.4	800	240	9.4	2.2	1.0	20	0.8	75	17.5
US-LT50B-17	1.50 - 2.50	13.2 - 23.0	1,700	240	9.4	2.2	1.0	20	0.8	75	17.5

Air Hose Size: 1/4 I.D. for US-LT10B - US-LT40B Series - 3/8" I.D. for US-LT50B Series

Air Inlet: 1/8 for US-LT10B - US-LT20B Series - 1/4" for US-LT30B - US-LT50B Series

## TORQUE CONTROL LIGHT TOUCH (LT) SERIES - ANGLE AND LEVER

Recommended Air Pressure: 85 psi

MODEL	TORQUE RANGE (SOFT JOINT)		FREE SPEED rpm	OVERALL LENGTH		WEIGHT		FROM CENTER TO OUTSIDE		HEX BIT OR DRIVE SIZE in	NOISE LEVEL dB(A)	AIR USAGE cfm
	Nm	in-lb		mm	in	lb	kg	mm	in			
ANGLE												
US-LT30B-11C	0.39 - 2.10	3.5 - 18.5	1,100	298	10.7	1.5	0.7	10	0.4	1/4	73	7.0
US-LT30B-17C	0.39 - 1.50	3.5 - 13.2	1,700	295	10.7	1.5	0.7	10	0.4	1/4	73	7.0
US-LT40B-05C	2.26 - 5.60	20.0 - 49.5	500	322	13.0	2.1	0.9	13	0.5	1/4	75	10.5
US-LT40B-08C	0.98 - 3.92	8.7 - 34.7	800	320	12.8	2.0	0.9	10	0.4	1/4	75	10.5
US-LT40B-15C	0.98 - 2.20	8.7 - 19.4	1,500	320	12.8	2.0	0.9	10	0.4	1/4	75	10.5
US-LT40-03C	4.90 - 9.80	43.4 - 86.8	300	360	14.2	2.4	1.1	13	0.5	1/4 Sq.	72	10.5
US-LT40-05C	2.26 - 5.70	20.0 - 50.2	500	322	13.0	2.1	0.9	13	0.5	1/4 Sq.	75	10.5
US-LT40-08C	0.98 - 3.92	8.7 - 34.7	800	320	12.8	2.0	0.9	10	0.4	1/4 Sq.	75	10.5
US-LT40-15C	0.98 - 2.06	8.7 - 18.2	1,500	320	12.8	2.0	0.9	10	0.4	1/4 Sq.	75	10.5
LEVER												
US-LT30BL-11	0.39 - 2.10	3.5 - 18.5	1,100	229	8.2	1.2	0.5	15	0.6	1/4	70	7.0
US-LT30BL-17	0.39 - 1.47	3.5 - 13.0	1,700	229	8.2	1.2	0.5	15	0.6	1/4	70	7.0
US-LT30BL-23	0.39 - 0.98	3.5 - 8.7	2,300	229	8.2	1.2	0.5	15	0.6	1/4	71	7.0
US-LT40BL-08	0.98 - 4.00	8.7 - 35.2	800	249	9.1	1.5	0.7	17	0.7	1/4	70	10.5
US-LT40BL-15	0.98 - 2.20	8.7 - 19.4	1,500	249	9.1	1.5	0.7	17	0.7	1/4	70	10.5
US-LT40BL-21	0.98 - 1.70	8.7 - 15.0	2,100	249	9.1	1.5	0.7	17	0.7	1/4	74	10.5

Angle Head Height: 32 - 36mm

Air Inlet: N.P.T. 1/4"

Air Hose Size: 1/4" I.D. for all models

## TORQUE CONTROL LIGHT TOUCH (LT) SERIES - PISTOL

Recommended Air Pressure: 85 psi

MODEL	TORQUE RANGE (SOFT JOINT)		FREE SPEED rpm	OVERALL LENGTH		WEIGHT		FROM CENTER TO OUTSIDE		NOISE LEVEL dB(A)	AIR USAGE cfm
	Nm	in-lb		mm	in	lb	kg	mm	in		
US-LT31PB-05	1.0 - 5.0	8.8 - 44.0	500	189	7.3	1.9	0.8	16.0	0.6	70	7.0
US-LT31PB-11	0.4 - 2.1	3.5 - 18.5	1,100	170	6.7	1.6	0.7	15.5	0.6	70	7.0
US-LT31PB-17	0.4 - 1.5	3.5 - 13.2	1,700	170	6.7	1.6	0.7	15.5	0.6	70	7.0
US-LT31PB-23	0.4 - 1.0	3.5 - 8.8	2,300	170	6.7	1.6	0.7	15.5	0.6	70	7.0
US-LT41PB-08	1.0 - 3.9	8.8 - 34.7	800	175	7.0	1.8	0.8	16.5	0.6	70	10.5
US-LT41PB-15	1.0 - 2.2	8.8 - 19.4	1,500	175	7.0	1.8	0.8	16.5	0.6	70	10.5
US-LT41PB-21	1.0 - 1.7	8.8 - 15.0	2,100	175	7.0	1.8	0.8	16.5	0.6	74	10.5
US-LT51PB-05	1.5 - 10.5	13.2 - 91.2	480	198	8.4	2.6	1.2	19.5	0.7	74	17.5
US-LT51PB-08	1.5 - 5.5	13.2 - 48.4	800	198	8.4	2.6	1.2	19.5	0.7	75	17.5
US-LT51PB-17	1.5 - 2.6	13.2 - 23.0	1,700	198	8.4	2.6	1.2	19.5	0.7	75	17.5
US-LT60P-03(P)	7.0 - 20.0	61.6 - 176.0	320	230	9.0	3.7	1.7	22.0	0.9	75	21.0
US-LT60P-07(P)	4.0 - 10.0	35.2 - 88.0	650	230	9.0	3.7	1.7	22.0	0.9	76	21.0
US-LT60P-11(P)	4.0 - 7.0	35.2 - 61.6	1,100	230	9.0	3.7	1.7	22.0	0.9	77	21.0

Air Hose Size: 1/4 I.D. for US-LT31PB & US-LT41PB Series

Air Inlet: N.P.T. 1/4" 3/8 I.D. for US-LT31PB-05, US-LT51PB Series & US-LT60P Series

(P) DENOTES 3/8" SQ. DRIVE FOR US-LT60P SERIES.

# PNEUMATIC SCREWDRIVERS



US-LT Series Model

## OPTIONAL CLUTCH SPRINGS

MODEL	CLUTCH SPRINGS PROVIDED		RECOMMENDED TORQUE RANGE HARD JOINT		CLUTCH SPRING CODE NUMBER
	Standard	Option	Nm	in-lb	
US-LT10/10B	Black		0.20 - 0.60	1.7 - 5.2	976-379-0
US-LT20B-10	Black		0.34 - 1.10	3.0 - 9.5	976-432-0
		Red	0.20 - 0.70	1.7 - 6.1	976-431-0
		Yellow	0.15 - 0.34	1.3 - 3.0	976-430-0
US-LT20B-18	Red		0.24 - 0.67	2.2 - 6.1	976-431-0
		Yellow	0.15 - 0.34	1.3 - 3.0	976-430-0
US-LT20B-26	Yellow		0.15 - 0.34	1.3 - 3.0	976-430-0
US-LT31PB-05	Red		2.35 - 5.00	20.9 - 44.0	976-493-0
		Pink	0.98 - 2.74	8.7 - 24.3	976-471-0
US-LT30 Series, 1100 rpm	Blue		0.98 - 2.1	8.7 - 18.5	976-472-0
		Red	0.67 - 1.76	6.1 - 15.6	976-493-0
		Pink	0.39 - 0.98	3.5 - 8.7	976-471-0
		Black (not included)	1.22 - 2.74	10.8 - 24.3	976-504-0
US-LT30 Series, 1700 rpm	Red		0.67 - 1.47	6.1 - 13.0	976-493-0
		Pink	0.39 - 0.98	3.5 - 8.7	976-471-0
US-LT30 Series, 2300 rpm	Pink		0.39 - 0.98	3.5 - 8.7	976-471-0
US-LT40-03C	Red		4.90 - 9.80	43.4 - 86.8	976-516-0
US-LT40 Series, 800 rpm	Black		1.57 - 3.92	13.9 - 34.7	976-515-0
		Red	0.98 - 2.17	8.7 - 19.1	976-516-0
		Yellow	0.98 - 1.67	8.7 - 14.8	976-517-0
US-LT40 Series, 1500 rpm	Red		0.98 - 2.17	8.7 - 19.1	976-516-0
		Yellow	0.98 - 1.67	8.7 - 14.8	976-517-0
US-LT40 Series, 2100 rpm	Yellow		0.98 - 1.67	8.7 - 14.8	976-517-0
US-LT50 Series, 500 rpm	Black		4.9 - 10.3	43.4 - 91.1	976-620-0
		Red	2.9 - 5.4	26.1 - 47.7	976-614-0
		Yellow	1.4 - 2.5	13.0 - 22.6	976-588-0
US-LT50 Series, 800 rpm	Red		2.7 - 5.4	24.3 - 47.7	976-614-0
		Yellow	1.4 - 2.5	13.0 - 22.6	976-588-0
US-LT50 Series, 1700 rpm	Yellow		1.4 - 2.6	13.0 - 23.0	976-588-0

## EXTERNAL TORQUE ADJUSTMENT (AIR SHUT-OFF)

Set the hand driver into the key hole on the Adjusting Gear, turn clockwise to increase torque. Turn counter clockwise to decrease torque.

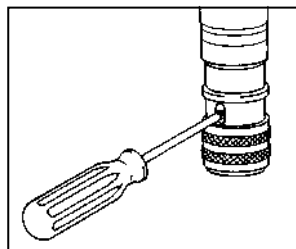

## SILENCER ASSEMBLIES

MODEL	DIRECT TYPE SILENCER	LEADER HOSE ASSEMBLY	EXHAUST HOSE ASSEMBLY
US-LT10 Series	N/A	934-201-0	459-885-1
US-LT20 Series	455-088-2	934-201-0	455-885-1
US-LT30 Series	408-088-2	934-150-0	408-885-0
US-LT40 Series	496-088-1	934-150-0	496-885-1

# PNEUMATIC SCREWDRIVERS



US-LD40P-15

Recommended Air Pressure: 85 psi

## DIRECT DRIVE SERIES

MODEL	MAX. TORQUE		FREE SPEED		OVERALL LENGTH		WEIGHT		FROM CENTER TO OUTSIDE		NOISE LEVEL dB(A)	AIR USAGE cfm	
	SOFT JOINT Nm	ft-lb	HARD JOINT Nm	ft-lb	rpm	mm	in	lb	kg	mm			in
PISTOL													
US-LD40P-08	4.8	3.6	5.2	4.2	940	130	5.1	1.5	0.7	17	0.7	70	14.0
US-LD40P-15	3.0	2.2	3.2	2.4	1,700	130	5.1	1.5	0.7	17	0.7	70	14.0
US-LD40P-21	2.0	1.5	2.8	2.1	2,500	130	5.1	1.5	0.7	17	0.7	74	14.0
US-LD50P-05	10.0	7.4	11.2	8.3	500	153	6.1	2.0	0.9	20	0.8	74	17.5
US-LD50P-08	6.5	4.8	7.8	5.8	900	153	6.1	2.0	0.9	20	0.8	75	17.5
US-LD50P-17	3.5	2.6	5.9	4.4	1,900	150	5.9	2.0	0.9	20	0.8	75	17.5
ANGLE													
US-3.5AGB	1.2	0.9	2.4	1.8	2,000	236	9.3	1.4	0.6	10.0	0.4	85	7.0

Air Hose Size: 1/4 I.D.

Air Inlet: N.P.T. 1/4



US-3.5PB

Recommended Air Pressure: 85 psi

## CUSHION CLUTCH SERIES

MODEL	TORQUE RANGE		FREE SPEED rpm	OVERALL LENGTH		WEIGHT LESS BIT		FROM CENTER TO OUTSIDE		NOISE LEVEL dB(A)	AIR USAGE cfm
	Nm	in-lb		mm	in	lb	kg	mm	in		
US-3.5PB	1.1 - 2.5	10 - 22	2,000	200	7.9	1.6	0.7	17	0.7	75	7.0
US-3.5B	1.2 - 2.5	11 - 22	2,000	214	8.4	1.4	0.6	17	0.7	75	7.0
US-5	3.4 - 7.7	30 - 68	1,400	258	10.1	2.4	1.1	21	0.8	75	7.0
US-50*	3.9 - 7.7	35 - 68	1,200	245	9.6	2.0	0.9	18	0.7	76	10.7

\* Push-To-Start

Air Hose Size: 1/4" I.D. for all models

Air Inlet: N.P.T. 1/4"



UW-6SLRDK

Recommended Air Pressure: 85 psi

## IMPACT SERIES

MODEL	TORQUE RANGE		FREE SPEED rpm	OVERALL LENGTH		WEIGHT LESS BIT		FROM CENTER TO OUTSIDE		NOISE LEVEL dB(A)	AIR USAGE cfm
	Nm	ft-lb		mm	in	lb	kg	mm	in		
PISTOL											
US-350PW*	4.2 - 8.3	3.1 - 6.1	16,000	121	4.8	1.2	0.5	17	0.7	82	7.0
US-450PW*			11,000	149	5.9	1.7	0.8	17	0.7	79	7.0
US-652PW*	7.1 - 12.1	5.2 - 8.9	9,300	155	6.1	1.9	0.8	23	0.9	78	8.8
UW-6SL(R)DK	5.7 - 15	4.2 - 11.1	8,500	165	6.5	2.2	1.0	22	0.8	90	10.5
UW-61E(R)DK	14 - 60	10.3 - 44.2	7,500	150	5.3	3.6	1.6	30	1.2	92	12.4
STRAIGHT											
US-450WB*	3.2 - 7.2	2.4 - 5.3	11,000	161	6.3	1.2	0.5	19	0.7	80	7.0
US-6W*			9,500	187	7.4	1.8	0.8	23	0.9	85	10.5
UW-6SSH(R)DK	16 - 36	11.8 - 26	7,300	265	10.4	2.8	1.3	24	0.9	91	12.4

Air Hose Size: 1/4" I.D. for US-350PW, US-450WB & US-652PW - Air Inlet: N.P.T. 1/4"

(R) Denotes Directional Muffled Rear Exhaust option \*Recommended air pressure: 57 psi

NOTE: Additional models available. Please contact AIMCO.

3/8" I.D. for UW-6 Series



# SIGNATURE SERIES PRECISION CLUTCH CORDLESS TOOLS



## SIGNATURE SERIES PRECISION TOOLS

Simple to use, yet sophisticated in performance, the AIMCO Signature Series Precision Clutch Tools produce the performance required to meet the needs of today's cordless tool applications.

These tools feature Ergonomic handle designs providing the operator with ideal balance and weight as they use the tool. These tools allow for fastening in tight locations at torques up to 9 Foot Pounds (12 NM) in the Pistol Configuration and 25 Foot Pounds (35 NM) in the Angle Nutrunner configurations. The Signature Series Precision Clutch Range features a wide range of torque outputs and the ability to program the tool speed for the demands of the application. Bright LED indicator lights provide clear feedback to the operator on OK/NOK tightening result, Tool Direction Setting and Battery Status. Signature Series Precision tools all operate with a single 18V Li Ion Battery and common chargers to maximize flexibility while minimizing cost associated with differing battery chemistries.

## SIGNATURE SERIES PRECISE QUICK RELEASE CLUTCH

The Signature Series Tool series feature a quick releasing clutch that delivers accuracy across multiple joint types. Each clutch assembly is constructed of precisely machined parts to ensure, not only accuracy, but durability over the lifespan of the tool. In addition to tight tolerances, the driving anvil of each tool is well supported to ensure that torque is precisely sensed by the clutch and not influenced by side loads or runout of the rotating components of the tool.

Whether the application is made up of soft materials such as plastics or gaskets or harder materials such as direct metal to metal joints, the Signature Series Precision Clutch tools will deliver the accuracy that the job requires.

Typical Torque Graph of the Signature Series Precision Cordless Tools

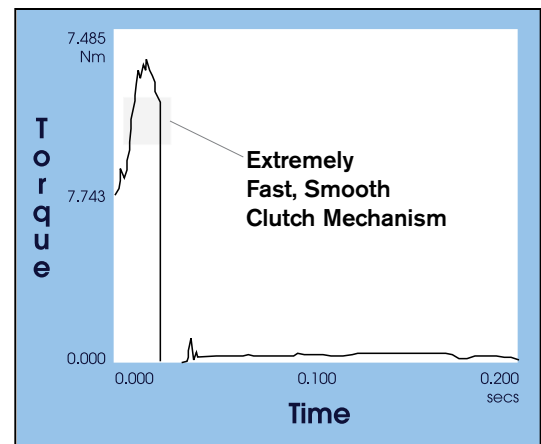

# SIGNATURE SERIES PRECISION CLUTCH CORDLESS TOOLS

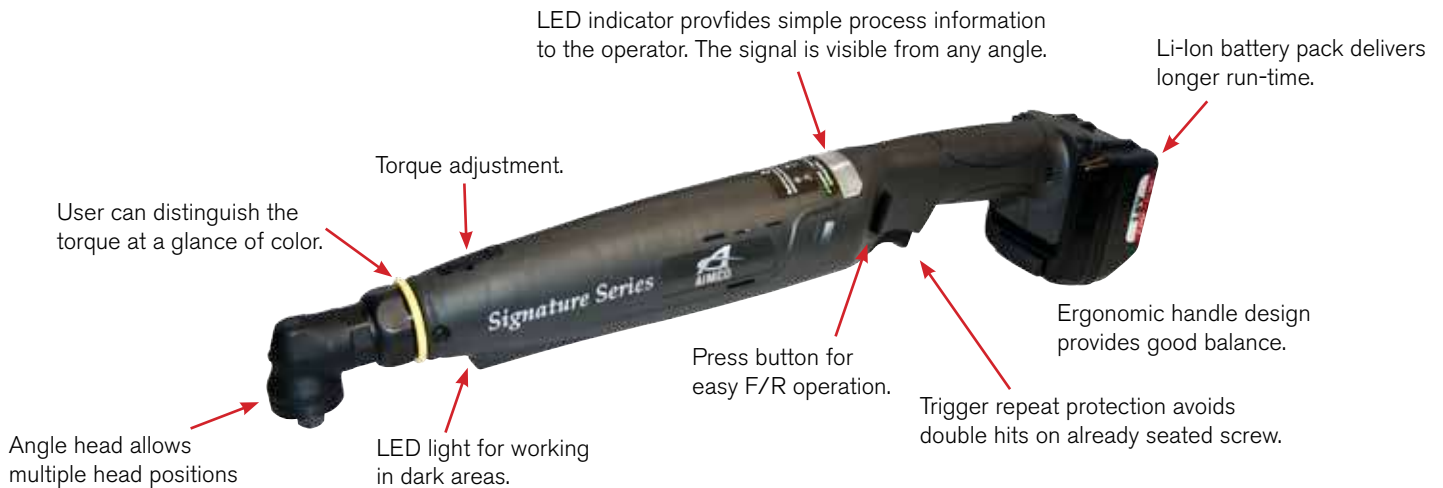

MODEL	TORQUE RANGE ft - lb Nm	FREE SPEED RPM RANGE (Programmable with Programmer Accessory)	BATTERY VOLTAGE	TOOL WEIGHT (W/O BATTERY)		ANVIL SIZE
				lb	kg	
<b>Pistol Grip</b>						
SPC-P2325Q	.6-2.2 .8-3	500-1550	18V	2.1	.95	1/4" hex
SPC-P2625Q	.7-4.4 1-6	300-1000	18V	2.1	.95	1/4" hex
SPC-P2925Q	1.1-6.6 1.5-9	300-800	18V	2.1	.95	1/4" hex
SPC-P21225Q	1.5-8.8 2-12	250-600	18V	2.1	.95kg	1/4" hex
<b>Angle Nutrunner</b>						
SPC-A21025Q	2.2-8.8 3-12	400-1000	18V	3.5	1.6	1/4" hex
SPC-A21025	2.2-8.8 3-12	400-1000	18V	3.5	1.6	1/4" Sq
SPC-A21038	2.2-8.8 3-12	400-1000	18V	3.5	1.6	3/8" Sq
SPC-A21625Q	3.7-13.3 5-18	300-600	18V	3.5	1.6	1/4" hex
SPC-A21625	3.7-13.3 5-18	300-600	18V	3.5	1.6	1/4" Sq
SPC-A21638	3.7-13.3 5-18	300-600	18V	3.5	1.6	3/8" Sq
SPC-A23038	5.9-22 8-30	250-480	18V	3.5	1.6	3/8" Sq
SPC-A23538	7.4-25.8 10-35	220-330	18V	3.5	1.6	3/8" Sq
SPC-A26538	UNDER DEVELOPMENT					

- Pistol Grip Tools include: Torque Adjustment Tool and one (1) 18V Li-Ion Battery
- Angle Nutrunners include: Torque Adjustment Tool, Head Indexing Spanner Wrench, and one (1) 18V Li-Ion Battery

# SIGNATURE SERIES CORDLESS TOOL BATTERY, CHARGER & ACCESSORIES

## BATTERIES AND CHARGERS

The AIMCO Signature Series charging and battery system could not be more simple. One universal battery and one universal charger interface with any of the Signature Series Precision Clutch Tools. Pistol Type, Angle Type, low amount of torque output, or the highest torque tool in the range, each tool utilizes the same 18V Lithium Ion battery for simplicity and superior charge life and weight. The batteries are all charged by the same charger that accepts input AC power of 100-240AC making use simple anywhere in the world.

The Signature Series Battery features a slim profile design and a slide mount connection to the tool insuring durability and ease of swapability when changing batteries for charging.



## BATTERY AND CHARGER SPECIFICATIONS

BATTERY	MODEL NUMBER	VOLTAGE	TYPE	CAPACITY	WEIGHT
	SPC-B218LI	18V	Li-Ion	2.0Ah	.8Lb/.4kg
CHARGER	MODEL NUMBER	OUTPUT	INPUT	DIMENSIONS	WEIGHT
	SPC-C218-19	18V-19.2V, 3.0A	100-240VAC, 50-60Hz	6.25" deep X 5" wide X 3.5" tall (w/o Battery) 158.75mm X 127mm X 89mm	1.2Lb/.54kg

## TOOL SPEED PROGRAMMER

The Signature Series Precision Cordless tool line features a unique ability to specifically program the running RPM into the tool within that tools range of operation. Each tool in the range has an integrated Mini USB connector that couples to the Signature Series Programmer Module. Simply connect the tool to the Programmer Module and flash the tool to the desired RPM required for the demands of the application. Once flashed, the tool will hold that RPM setting until a change is desired and it is re-flashed regardless of battery changes. New tools, that have not been specifically set by the programmer module will run at their maximum rated RPM as shown in the catalog table and on the tool label.



SPC-2-PGM

## QUICK CLIP

Carry your Signature Series Pistol Tool on any work belt with the Quick Clip. The two piece Quick Clip comes with a belt clip and a stretch cord attachment for the tool. The patented ball feature allows for quick and easy release on the belt. The Quick Clip keeps the tool well balanced and allows the operator's hands to be free for other tasks.



SPC-QC

## TOOL BASKETS



Tool Baskets are a great way to keep the Signature Series tool in place when not being used. AIMCO tool baskets can be affixed to the bench or rack and can be used for either the Pistol or Right Angle Tools.

## HOLSTERS



For ease in carrying your Signature Series Pistol and Right Angle Tools, and to protect your application, AIMCO offers several holster designs.

SPC-P-HL



# ELECTRIC SCREWDRIVERS

## ELECTRA SERIES

- Available in Push-To-Start and Lever Start styles.
- Ergonomic Design – Lightweight, compact housings ensure operator comfort during operation.
- Accurate Torque Control – Precise controlled fastening with automatic shut-off clutches.
- External Brush Replacement – Virtually no down time for brush replacement.
- External Torque Adjustment – Torque level can be easily adjusted by simply turning the external adjustment ring.
- UL Listed and CE Certified – Drivers meet electrical safety standards in both the U.S. and Europe.
- Direct Plug-In Style – Offers easy and convenient start-up (certain models) simply plug it in.
- State-of-the-Art Motor Design – Ensures comfortable grip temperature for operator and extended motor life.



AE-5681



## PRECISION SERIES

For low torque Applications

- Featuring ergonomic design in shape and materials.
- Comes with options such as long-life brushless motors and adjustable speed power supplies.

## STANDARD MODELS

- Optional Speed Control Power Supply – Enables infinite control from 20% to 100% of maximum tool speed and adjustable soft start to minimize cross threading.
- Ergonomic Housing – Oval shape conforms to hand.
- Duralite – New casing material provides a secure grip.
- Integrated Lever – Feather touch integrated lever reduces travel and stress. Requires only 2 mm of travel to activate.
- External Torque Control – Twist and go.

## ELECTRA LOW ESD SERIES

- Grounded Bit – Grounded chuck assembly routes any existing charge to ground.
- Carbonized Housing – Handle material and buttons are constructed of carbonized plastic throughout, enabling any charge received by the handle to be routed to ground.
- Long-Lasting ESD Resistant Handle – Material will maintain its integrity for the life of the handle, unlike coatings or paints.



AE-5681ESD



## ELECTRA SLIP CLUTCH SERIES

- High-Speed Performance – For quick and consistent assembly and disassembly.
- Maximum Ergonomics and Convenience – Offers a combination of a slip clutch with a high speed motor to provide low torque reaction; one of the best power-to-weight ratios in the industry.
- Added Maintenance Feature – A LED light indicates when to change brushes. Brush cap contains a switch that shuts off the power during brush replacement.
- Direct 110V Plug-In – Eliminates the need for an external power supply.
- 1/4" Hex Quick Change Chuck – For easy bit changes.
- External Torque Collar – For easy torque adjustment.



AE-6300



## EXTENDED LIFE MODELS

- Sealed Swiss Motor – For higher duty cycles, longer life, and less maintenance. Sealed casing means no brush changes are necessary.
- Extended Warranty on tool motor – Three year standard motor warranty.
- Compact Power Supply – Makes setup a breeze.

# ELECTRIC SCREWDRIVERS

## ELECTRA SERIES

MODEL	TORQUE RANGE		FREE SPEED rpm	WEIGHT		LENGTH		HEX DRIVE		POWER SOURCE
	in-lb	kgf-cm		lb	kg	in	mm	in	mm	
<b>PUSH-TO-START DIRECT PLUG-IN SERIES</b>										
AE-5681 <sup>3</sup>	3.5 - 15.6	4 - 18.0	1,000	1.2	0.5	9.3	237	1/4	6.4	115V AC <sup>1</sup>
AE-8681 <sup>4</sup>	15 - 45	23.0 - 51.8	600	1.6	0.7	10.6	269	1/4	6.4	115V AC <sup>1</sup>
<b>LOW VOLTAGE LEVER START SERIES<sup>2</sup></b>										POWER SUPPLY:
AE-2020B	.35 - 1.3	.40 - 1.5	720	0.7	0.3	8.0	203	1/4	6.4	See top
AE-4020	.9 - 5	1.0 - 6.0	720	0.7	0.3	8.0	203	1/4	6.4	of page 36
AE-4520	1.3 - 8.7	1.5 - 10.0	720	0.7	0.3	8.0	203	1/4	6.4	for required
AE-7010	6.1 - 17.4	7.0 - 20.0	750	1.4	0.6	9.3	236	1/4	6.4	power supplies <sup>2</sup>
AE-8010	10.4 - 26.0	12.0 - 29.9	550	1.4	0.6	9.3	236	1/4	6.4	
<b>LOW VOLTAGE PUSH-TO-START SERIES<sup>2</sup></b>										POWER SUPPLY:
AE-7010PS	6.1 - 17.4	7.0 - 20.0	750	1.4	0.6	9.3	236	1/4	6.4	See page 36 for
AE-8010PS	10.4 - 26.0	12.0 - 29.9	550	1.4	0.6	9.3	236	1/4	6.4	power supplies <sup>2</sup>

- 1 220V AC is available upon request
- 2 Low voltage units require an external power supply.
- 3 AE-5681 includes a torque cover
- 4 AE-8681 includes a pistol grip handle adapter

## ELECTRA LOW ESD SERIES

MODEL	TORQUE RANGE		FREE SPEED rpm	WEIGHT		LENGTH		HEX DRIVE		POWER SOURCE
	in-lb	kgf-cm		lb	kg	in	mm	in	mm	
AE-5681ESD	3.5 - 15.6	4 - 18.0	1,000	1.2	0.5	9.3	237	1/4	6.4	115V AC <sup>1</sup>
AE-4520ESD <sup>2</sup>	1.3 - 8.7	1.5 - 10.0	720	0.9	0.4	8.0	204	1/4	6.4	35V DC

- 1 220V AC is available upon request
- 2 Low voltage units require an external power supply.

## ELECTRA SLIP CLUTCH SERIES

MODEL	RECOMMENDED TORQUE RANGE		FREE SPEED rpm	WEIGHT		LENGTH		HEX DRIVE		POWER SOURCE
	in-lb	kgf-cm		lb	kg	in	mm	in	mm	
AE-2015	1.7 - 15.6	2.0 - 18.0	1000	1.2	.55	9.2	234	1/4	6.4	110V/120VAC <sup>1</sup>

- 1 220V AC is available upon request

## PRECISION SERIES

MODEL	TORQUE RANGE		FREE SPEED rpm	WEIGHT		LENGTH		HEX DRIVE in
	in-lb	kgf-cm		lb	kg	in	mm	
<b>STANDARD</b>								
AE-6300	.85 - 5.0	1.0 - 5.8	725	0.9	0.4	8.5	216	1/4
AE-6450	1.3 - 8.7	1.5 - 10.0	770	0.9	0.4	8.5	216	1/4
<b>HIGH SPEED</b>								
AE-6300S	1.2 - 5.5	1.4 - 6.3	920	0.9	0.4	8.5	216	1/4
AE-6450S	1.3 - 8.7	1.5 - 10.0	920	0.9	0.4	8.5	216	1/4
<b>EXTENDED LIFE</b>								
AE-6300M	1.0 - 5.5	1.1 - 6.3	550	0.9	0.4	8.5	216	1/4

## POWER SUPPLIES

MODEL	FEATURE	DIMENSIONS		WEIGHT	
		in	mm	lb	kg
<b>STANDARD AND HIGH SPEED</b>					
AE-24PS	Standard PS	2.6 x 1.6 x 5.0		66 x 14 x 127	
APS-35W	Variable Speed / Soft Start	2.6 x 1.6 x 5.0		66 x 14 x 127	
<b>EXTENDED LIFE</b>					
APM-30	Extended Life PS	2.1 x 3.4 x 1.9		53 x 87 x 48	

# ELECTRIC SCREWDRIVERS



APS-35W



AE-24PS and AE-78PS

## ELECTRA SERIES ACCESSORIES - POWER SUPPLIES

MODEL	COMPATIBLE SCREWDRIVERS	TOOL RPM	VOLTAGE CONVERSION	DIMENSIONS (LB)	WEIGHT (KG)
AE-24PS	AE-2020B AE-4020 AE-4520 AE-4520ESD	AE-6300 AE-6300S AE-6450 AE-6450S	720  110V AC / 35V DC	2.6 x 1.6 x 5.0 66 x 41 x 127 mm	1.0 .45
APS-35	AE-2020B AE-4020 AE-4520 AE-4520ESD	AE-6300 AE-6300S AE-6450 AE-6450S	VARIABLE SPEED SOFT START 110V AC / 35V DC	2.6 x 1.6 x 5.0 66 x 41 x 127 mm	1.0 .05
AE-78PS	AE-7010 AE-7010PS	AE-8010 AE-7010	STANDARD 110V AC / 30V DC	1.6 x 5.0 x 2.6 41 x 127 x 66 mm	1.0 .45
APM-30	AE-6300M	550	110V AC / 35V DC	2.1 x 3.4 x 1.9 53 x 87 x 48mm	0.4 .02



### ANGLE HEAD ATTACHMENTS

Available for lever start series.

Part # AE-2045A or AE-7080A.

Not available on Low ESD Series.



### PISTOL GRIP HANDLE

Converts to a pistol style driver for horizontal fastening. Available for Trigger Start only (included with AE-8681).



### TORQUE COVER

Prevents accidental torque adjustment by the operator (included with AE-5681).



### FASTENER COUNTER

Verifies and error-proofs assembly process.

## OPTIONAL ACCESSORIES

ITEM	MODEL	COMPATIBLE SCREWDRIVERS
Angle Head Attachments	AE-2045A AE-7080A	For AE-2020B, AE-4020, AE-4520 For AE-7010, AE-8010
Pistol Grip Handle	AE-PG7080	For AE-7010, AE-1070PS, and AE-8010
Torque Cover	AE-TC2045 AE-TC7080 4H2055	For AE-2020B, AE-4020, AE-4520 For AE-7010, AE-7010PS, AE-8010 For AE-8681
Fastener Counter	TM-45 TM-65	For AE-2020, AE-4020, AE-4520 Standard and ESD types For AE-7010, AE-8010 and AE-8010PS

# IMPACT TOOLS

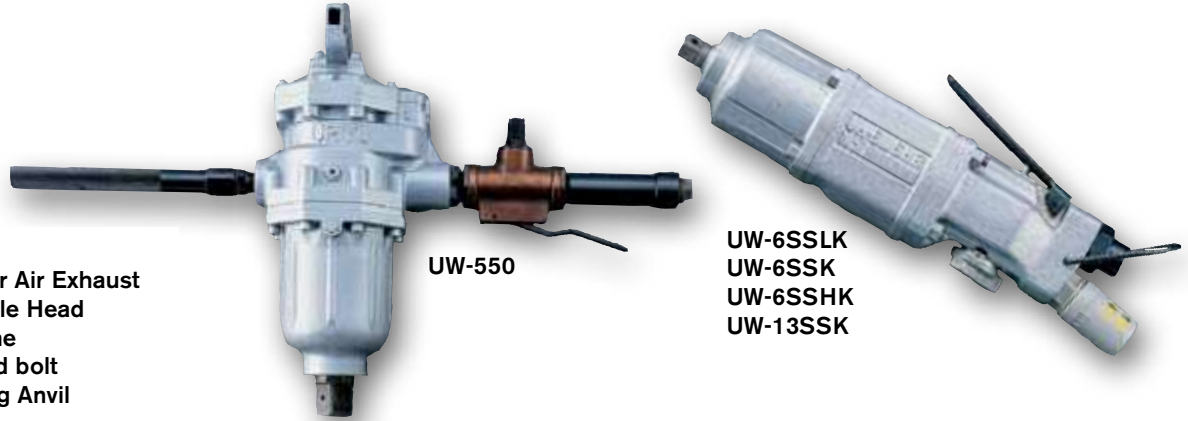

**KEY**  
**R:** Rear Air Exhaust  
**C:** Angle Head  
**SS:** Inline  
**ST:** Stud bolt  
**L:** Long Anvil

**UW-550**

**UW-6SSLK**  
**UW-6SSK**  
**UW-6SSHK**  
**UW-13SSK**

NOTE: Additional models are available. Please contact AIMCO.

Recommended Air Pressure: 85 psi

MODEL	CAPACITY		SPEED rpm	OVERALL LENGTH		WEIGHT		FROM CENTER TO OUTSIDE		SQ. DR. OR HEX SIZE in	NOISE LEVEL dB(A)	AVERAGE AIR CONSUMPTION cfm
	mm	in		mm	in	kg	lb	mm	in			
UW-6SLRDK	6	1/4	8,500	169	6.6	1.4	3.1	31.0	1.2	1/4	91	10.5
UW-6SLK	6	1/4	8,500	165	6.5	1.0	2.1	22.0	0.8	1/4	92	10.5
UW-6SSK	6	1/4	7,500	194	7.6	1.0	2.2	22.0	0.8	1/4	91	10.5
UW-6SSLK	6	1/4	8,500	202	7.9	0.9	2.0	22.0	0.8	1/4	91	10.5
UW-6SSDK	6	1/4	7,500	194	7.6	1.0	2.2	28.0	1.1	1/4	91	10.5
UW-6SSHDK	6	1/4	8,500	202	7.9	0.9	2.0	22.0	0.8	1/4	91	10.5
UW-6SSLRDK	6	1/4	8,500	202	7.9	0.9	2.0	22.0	0.8	1/4	91	10.5
UW-6SSRK	6	1/4	7,500	201	7.9	1.0	2.1	29.5	1.2	3/8	90	10.5
UW-6SL(R)K	6	1/4	6,500	260	10.2	1.1	2.5	31.0	1.2	3/8	92	10.5
UW-6CSK	6	1/4	7,500	271	10.7	1.4	3.1	22.0	0.8	3/8	94	10.5
UW-6CSLRK	6	1/4	8,000	238	8.3	1.2	2.6	14.0	0.6	3/8	93	10.5
UW-6SK	6	1/4	7,500	160	6.3	1.2	2.7	22.0	0.8	3/8	93	10.5
UW-6SSHK	8	5/16	7,500	211	8.3	1.3	2.8	24.0	0.9	1/4	92	12.4
UW-6SSHRDK	8	5/16	7,300	238	9.4	1.3	2.9	29.5	1.2	1/4	91	12.4
UW-6SSHRK	8	5/16	7,300	228	8.9	1.3	2.8	29.0	1.1	3/8	91	12.4
UW-61E(R)K	8	5/16	7,300	154	6.0	1.5	3.3	29.5	1.2	3/8	91	12.4
UW-6CSH(R)K	8	5/16	7,300	256	10.1	1.7	3.8	27.5	1.1	3/8	94	10.5
UW-ST6SHK	8	5/16	6,500	170	6.7	1.7	3.7	24.0	1.0	3/8	92	14.0
UW-8SH(R)K	8	5/16	7,300	172	6.8	1.6	3.4	31.0	1.2	1/2	93	14.0
UW-9CSK	10	3/8	7,000	338	13.3	2.8	6.1	34.0	1.3	1/2	95	12.4
UW-9SRK	10	3/8	7,000	173	6.8	1.8	3.9	27.5	1.1	1/2	93	16.0
UW-9SK	10	3/8	7,000	185	7.2	1.8	4.0	34.0	1.3	1/2	95	17.6
UW-9SSK	10	3/8	7,000	290	11.4	2.1	4.6	34.0	1.3	1/2	95	16.0
UW-140P(WR)	12	1/2	6,500	190	7.5	2.7	5.9	30.0	1.2	1/2	93	25.0
UW-10SH(R)K	12	1/2	6,000	197	7.8	2.1	4.7	30.5	1.2	1/2	95	16.0
UW-13CSK	13	1/2	6,500	375	14.8	5.2	11.4	39.0	1.5	1/2	97	26.5
UW-13S(R)K	13	1/2	6,000	205	8.1	2.6	5.7	37.5	1.5	1/2	95	16.0
UW-13SSK	13	1/2	6,300	303	11.9	3.2	7.0	34.0	1.3	1/2	97	19.4
UW-131ERK	13	1/2	5,500	210	8.3	3.0	6.5	37.5	1.5	1/2	97	19.4
UW-220P(L)	19	3/4	5,500	225	8.9	4.4	9.6	42.0	1.7	3/4	95	25.0
UW-251P(L)	25	1	5,500	275	10.8	8.0	17.6	51.5	2.0	1	95	28.0
UW-381	38	1-1/2	4,700	355	13.0	9.5	20.9	58.5	2.3	1	100	31.5
UW-381P(L)	38	1-1/2	4,700	425	16.8	10.0	22.0	58.5	2.3	1	99	31.5
UW-401(L)	38	1-1/2	3,200	421	16.6	15.1	33.2	62.5	2.5	1	110	42.4
UW-550	56	2-1/4	3,500	525	20.7	36.0	79.2	78.0	3.1	1-1/2	112	79.0
UW-75S	76	3	1,400	668	26.3	56.0	123.0	91.0	3.6	1-1/2	112	114.0

Air Hose Size: 3/8" I.D. (UW-6 - 140P)  
 1/2 I.D. (UW-220P(L))  
 3/4 I.D. (UW-75S)

Air Inlet: N.P.T. 1/4" (UW-6 - 140P)  
 N.P.T. 3/8 (UW-220P(L))  
 N.P.T. 1 (UW-75S)

NOTE: Additional models available. Please contact AIMCO.



# GRINDERS AND SANDERS

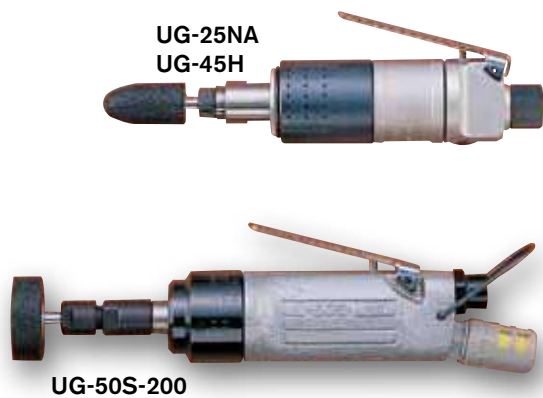

## GRINDERS

Recommended Air Pressure: 85 psi

MODEL	CAPACITY (WHEEL SIZE) in	SPEED rpm	RATED HORSEPOWER hp	OVERALL LENGTH		OVERALL HEIGHT		WEIGHT		NOISE LEVEL dB(A)	AVERAGE AIR CONSUMPTION cfm
				mm	in	mm	in	kg	lb		
UAG-40SB-136	4	13,600	0.5	208	8.2	76	3.0	1.5	3.3	84	34.0
UAG-40SBL-136	4	13,600	0.5	246	9.7	76	3.0	1.3	2.9	84	34.0
UAG-50SBL-120	5	12,000	0.5	246	9.7	76	3.0	1.4	3.1	82	34.0
UAG-50SBL-109	5	10,900	0.5	246	9.7	76	3.0	1.6	3.5	82	34.0
UAG-70SBL-76	7	7,600	1.1	300	11.8	98	3.9	2.9	6.4	83	57.0
UAG-90SBL-59	9	5,900	1.4	308	12.1	98	3.9	3.3	7.3	88	67.0
UAG-50SBL-109	5	10,900	0.5	246	9.7	76	3.0	1.6	3.5	82	34.0
UAG-70SBL-76	7	7,600	1.1	300	11.8	98	3.9	2.9	6.4	83	57.0
UAG-90SBL-59	9	5,900	1.4	308	12.1	98	3.9	3.3	7.3	88	67.0
VG6-45	6	4,500	1.7	-	-	196	7.7	4.6	10.1	89	77.7
VG6-59	6	5,900	1.7	-	-	196	7.7	4.6	10.1	89	77.7
VG7-59	7	5,900	1.7	-	-	179	7.0	4.3	9.5	89	81.0
VG7-76	7	7,600	1.7	-	-	179	7.0	4.3	9.5	89	81.0
VG9-59	9	5,900	1.7	-	-	179	7.0	4.6	10.1	87	81.0

Air Hose Size: 3/8" I.D. -

Air Inlet: N.P.T. 1/4" - N.P.T. 3/8" (UAG-90SBL-59)

NOTE: Additional models available. Please contact AIMCO.

## GRINDERS / SANDERS

Recommended Air Pressure: 85 psi

MODEL	CAPACITY (WHEEL SIZE) in	COLLET CHUCK SIZE in	SPEED rpm	RATED HORSEPOWER hp	OVERALL LENGTH		WEIGHT		NOISE LEVEL dB(A)	AVERAGE AIR CONSUMPTION cfm
					mm	in	kg	lb		
UG-25NA	-	1/4	25,000	.20	153	6.0	0.5	1.2	82	10.7
UG-38N	-	1/4	25,000	.25	164	6.5	0.6	1.3	85	10.7
UG-38NA	-	1/4	20,000	.25	165	6.5	0.7	1.4	75	14.0
UG-38NL	-	1/4	25,000	.25	330	13	0.9	2.0	85	10.7
UG-38NS	-	1/4	25,000	.25	168	6.6	0.6	1.3	85	10.7
UG-50S-200	-	1/4	20,000	.20	198	7.8	0.6	1.3	73	14.0
UG-60S-29	-	1/4	25,000	.50	227	8.9	1.1	2.3	77	18.0
UG-45H	-	1/4	18,000	.30	196	7.7	0.8	1.8	76	22.0
UG-20A-200	-	1/4	20,000	.15	131	5.2	0.5	1.1	75	10.7
UG-20A-120	-	1/4	12,000	.15	131	5.2	0.5	1.1	75	10.7
UG-50S-200A	-	1/4	20,000	.20	195	7.7	0.9	2.0	76	10.7
UG-65EB	2.5	-	14,600	.30	242	9.8	1.3	2.8	95	22.0
UG-65EL	2.5	-	14,600	.30	272	10.7	1.4	3.1	95	22.0
UG-65ER	2.5	-	14,600	.30	271	10.7	1.5	3.3	85	22.0
UG-65EBL	2.5	-	14,600	.30	272	10.7	1.4	3.1	95	22.0
UG-65OEL	2.5	-	14,600	.30	420	16.5	1.6	3.4	85	22.0
UG-1250L-72	5	-	7,200	.55	436	17.2	2.8	6.2	88	32.7
UP-25DB	5	-	9,000	0.3	212	8.3	1.7	3.7	73	7.0

Air Hose Size: 3/8" I.D. - 1/2" I.D. (UG-1250L-72)

Air Inlet: N.P.T. 1/4" N.P.T. 3/8" (UG-1250L-72)

NOTE: Additional models available. Please contact AIMCO.

# DRILLS & PERCUSSION TOOLS



**UD-60S-29**

Recommended Air Pressure: 85 psi

## DRILLS

MODEL	CAPACITY		SPEED rpm	OVERALL LENGTH		WEIGHT WITH CHUCK		FROM CENTER TO OUTSIDE		NOMINAL CHUCK SIZE in	TYPE OF SPINDLE in-thrd	NOISE LEVEL dB(A)	AVERAGE AIR CONSUMPTION cfm
	mm	in		mm	in	kg	lb	mm	in				
UD-50-200	3	1/8	23,000	135	5.3	0.7	1.5	21.0	0.8	5/16	3/8-24UNF	73	14
UD-50-45	6	1/4	5,000	145	5.7	0.8	1.9	21.0	0.8	5/16	3/8-24UNF	72	14
UD-50-22	8	5/16	2,200	140	5.5	0.9	2.0	21.0	0.8	5/16	3/8-24UNF	72	14
UD-60-29	8	5/16	2,900	167	6.6	1.1	2.4	22.5	0.9	5/16	3/8-24UNF	77	18
UD-60-20	8	5/16	2,000	180	7.1	1.2	2.6	22.5	0.9	5/16	3/8-24UNF	77	18
UD-60-15	8	5/16	1,600	180	7.1	1.2	2.6	22.5	0.9	5/16	3/8-24UNF	76	18
UD-60-07	13	1/2	700	214	8.4	1.4	3.1	22.5	0.9	1/2	1/2-20UNF	75	18
UD-60-04	13	1/2	500	220	8.6	1.4	3.1	22.5	0.9	1/2	1/2-20UNF	75	18
UD-80-12	13	1/2	1,200	212	8.3	1.8	4.0	26.0	1.0	1/2	1/2-20UNF	79	23
UD-80-07	13	1/2	700	242	9.5	2.3	5.1	26.0	1.0	1/2	1/2-20UNF	79	23
UD-80-04	13	1/2	400	265	10.4	2.9	6.4	26.0	1.0	5/8	5/8-16UNF	79	23
UD-50S-45	6	1/4	5,000	210	8.3	0.8	1.9	21.0	0.8	5/16	3/8-24UNF	77	14
UD-50S-22	8	5/16	2,200	205	8.1	0.8	1.8	21.0	0.8	5/16	3/8-24UNF	77	18
UD-60S-29	8	5/16	2,900	227	8.9	1.0	2.3	22.5	0.9	5/16	3/8-24UNF	77	18
UD-60S-15	8	5/16	1,600	238	9.4	1.2	2.6	22.5	0.9	5/16	3/8-24UNF	76	23
UD-50S-45A	4	5/32	5,000	253	9.9	0.9	2.0	21.0	0.8	-	1/4-28UNF	79	14
UD-60S-29C	8	5/16	2,900	276	10.9	1.5	3.3	22.5	0.9	5/16	3/8-24UNF	79	18
UD-60S-15C	8	5/16	1,600	283	11.1	1.6	3.5	22.5	0.9	5/16	3/8-24UNF	79	18
UD-80-12G*	13	1/2	1,200	212	8.3	1.8	4.0	26.0	1.0	1/2	1/2-20UNF	79	23
UT-66B-07	8	5/16	800	196	7.7	1.4	3.1	25.0	1.0	-	-	85	14.4
URD-22RR	22	7/8	600	442	17.4	5.8	12.8	39.0	1.6	-	-	95	46

Air Hose Size: 3/8" I.D.

Air Inlet: N.P.T. 1/4"

NOTE: Other models are available. Please contact AIMCO.

\*Grip Handle

## RIVETING HAMMERS

Recommended Air Pressure: 85 psi

MODEL	CAPACITY		BLOW PER MIN. bpm	OVERALL LENGTH		WEIGHT		PISTON DIAMETER		PISTON STROKE		NOISE LEVEL dB(A)	AVERAGE AIR CONSUMPTION cfm
	DURALUMIN in	STEEL in		mm	in	kg	lb	mm	in	mm	in		
SBH-0	3/32	-	6,500	123	4.2	0.3	0.7	10.0	0.4	23	0.9	90	3.5
SBH-1A(R,H)*	7/64	-	4,000	209	8.2	0.9	1.9	11.1	0.4	56	2.2	92	5.0
BRH-1U(R,H)*	1/8	3/32	2,800	122	5.0	1.1	2.4	14.3	0.6	38	1.5	95	12.0
BRH-1US(R,H)*	1/8	3/32	2,800	180	7.1	1.0	2.2	14.3	0.6	38	1.5	95	12.0
BRH-1UG(R,H)*	1/8	3/32	2,800	187	7.4	1.8	3.9	14.3	0.6	38	1.5	95	12.0
BRH-5U(R,H)*	1/4	3/16	1,800	190	7.5	1.4	3.1	12.7	0.5	100	4.0	95	13.0
BRH-5US(R,H)*	1/4	3/16	1,800	248	9.8	1.5	3.2	12.7	0.5	100	4.0	95	13.0
BRH-5UG(R,H)*	1/4	3/16	1,800	255	10.2	2.1	4.7	12.7	0.5	100	4.0	95	13.0
BRH-1UV(R,H)*	1/8	3/32	2,800	162	6.4	1.4	3.0	14.3	0.6	38	1.5	91	12.0
BRH-5UV(R,H)*	1/4	3/16	1,800	227	9.0	1.7	3.7	12.7	0.5	100	4.0	91	13.0
BRH-1USV(R,H)*	1/8	3/32	2,800	271	10.7	1.6	3.5	14.3	0.6	38	1.5	91	12.0
BRH-5USV(R,H)*	1/4	3/16	1,800	338	13.3	1.9	4.1	12.7	0.5	100	4.0	91	12.0
BRH-7(R,H)*	-	-	3,400	190	7.5	1.6	3.6	19.1	0.75	50	2.0	100	17.0

Air Hose Size: 3/8" I.D.

Air Inlet: N.P.T. 1/4"

\* R - Round Bushing H - Hex Bushing

## ONE SHOT HAMMERS

MODEL	BLOW POWER lb	RIVET SET DIA. x LENGTH in	SHANK DIA.		STROKE		LENGTH		WEIGHT	
			mm	in	mm	in	mm	in	lb	kg
CB-13P	1.7	4.04 x 9.86	-	-	3.0	0.12	185	7.3	0.7	0.3
RH-20	20.4	-	10.2	0.401	29.8	1.2	213	8.4	2.0	0.9
RH-80	27.6	-	10.2	0.401	29.8	1.2	254	10.0	2.9	0.3
RH-100Z	78.1	-	10.2	0.401	29.8	1.2	328	12.9	3.9	1.8

Air Hose Size: 3/8" I.D.

Air Inlet: N.P.T. 1/4"

NOTE: Additional models available. Please contact AIMCO.

# SCREW PRESENTERS: OVERVIEW

For semi-automated assembly, look no further – AIMCO AcraFeed® screw presenters provide:

## PRODUCTIVITY

- One hand operation eliminates manual handling of screws.
- Screw is presented to operator for easy magnetic or vacuum pickup.
- Keeps workspace clear of dropped fasteners.
- Quick feed rate from oscillating hopper design – up to two (2) screws per second.
- Large hopper holds approximately 1000 – 1500 fasteners.
- Solid design – no tie downs or straps required.

## FLEXIBILITY

- Perfect for contract or dedicated assembly.
- Switch rails in minutes for different screw sizes.

## ERGONOMICS

- Allows for fewer arm and hand movements.

## RELIABILITY

- Heavy duty industrial design.
- Modular design for easy repairs.

## QUALITY

- Uses existing or our new torque control drivers.
- Keeps stray fasteners from getting into assemblies.

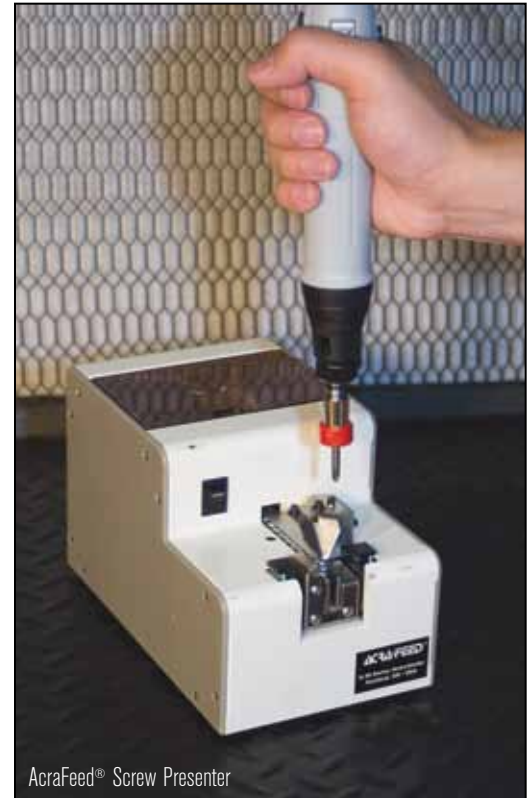

# ACRA-FEED®

## FASTENING IN 3 EASY STEPS



**1** Load screws into the hopper. There is no side to load unit and no gates to limit capacity.



**2** Address screw with magnetized bit.



**3** Bring screw to workpiece and fasten parts.

# A-50 SCREW PRESENTERS



**ROBOTIC**



**COMPACT ROBOTIC**



**STANDARD**

## STANDARD SCREW PRESENTERS

MODEL	ADDITIONAL RAIL	SCREW SIZE		MAX. SCREW LENGTH	
		Part No	in	mm	in
A-50A-0	AR-0	#0	1.4	.39	10
A-50A-1.7	AR-1.7	-	1.7	.39	10
A-50B-1	BR-1	#1	2.0	.75	18
A-50B-2	BR-2	#2	2.3	.75	18
A-50B-3	BR-3	#3	2.6	.75	18
A-50B-4	BR-4	#4	3.0	.75	18
A-50C-6	CR-6	#6	3.5	.75	18
A-50C-8	CR-8	#6-8	4.0	.75	18
A-50C-10	CR-10	#10	5.0	.75	18

Dimensions: 5.1 (W) x 8.5 (L) x 5.3 (H) Weight: 7.0 lbs.

## ROBOTIC SCREW PRESENTERS

MODEL	ADDITIONAL RAIL	SCREW SIZE		MAX. SCREW LENGTH	
		Part No	in	mm	in
A-50ARB-0	AR-RBT-0	#0	1.4	.39	10
A-50ARB-1.7	AR-RBT-1.7	-	1.7	.39	10
A-50BRBT-1	BR-RBT-1	#1	2.0	.70	18
A-50BRBT-2	BR-RBT-2	#2	2.3	.70	18
A-50BRBT-3	BR-RBT-3	#3	2.6	.70	18
A-50BRBT-4	BR-RBT-4	#4	3.0	.70	18
A-50CRBT-6	CR-RBT-6	#6	3.5	.70	18
A-50CRBT-8	CR-RBT-8	#6-8	4.0	.70	18
A-50CRBT-10	CR-RBT-10	#10	5.0	.70	18

Dimensions: 5.1" (W) x 10.8" (L) x 5.3" (H) Weight: 9.2 lbs.

## COMPACT ROBOTIC SCREW PRESENTERS

MODEL	ADDITIONAL RAIL	NOMINAL SCREW SIZE		MAX. SCREW LENGTH	
		Part No.	in	mm	in
A-50ARBTC-0	AR-RBTC-0	#0	1.4	.390	10
A-50ARBTC-1.7	AR-RBTC-1.7	-	1.7	.390	10
A-50BRBTC-1	BR-RBTC-1	#1	2.0	.700	18
A-50BRBTC-2	BR-RBTC-2	#2	2.3	.700	18
A-50BRBTC-3	BR-RBTC-3	#3	2.6	.700	18
A-50BRBTC-4	BR-RBTC-4	#4	3.0	.700	18
A-50CRBTC-6	CR-RBTC-6	#6	3.5	.700	18
A-50CRBTC-8	CR-RBTC-8	#6-8	4.0	.700	18
A-50CRBTC-10	CR-RBTC-10	#10	5.0	.700	18

Dimensions: 7.2 (L) x 4.9 (W) x 5.7 (H)

Weight: 6.7 lbs.

## OPTIONAL ACCESSORIES

MODEL	PART NO.
Mag-O-Net Bit Magnetizer	AM1/42, AM52, AM3/162
A-50B Series Bit Guide Protector	NJ08004TING#23
A-50C Series Bit Guide Protector	NJ08004TING#45

## WHICH TO USE...?

### Standard Screw Presenters

For manual assembly stations where the operator must otherwise pick up and hold fasteners by hand.

### Robotic Screw Presenters

For automated fastening systems or manual systems using vacuum assist to pick up non-ferrous fasteners.

### Compact Robotic Screw Presenters

For automated systems, or manual systems, using vacuum-assist to pick up nonferrous fasteners when work space is limited,

# SCREW FEEDERS

**Reduces Cycle Time By Approximately Two Seconds Per Fastener**

## FEATURES AND BENEFITS

- Delivers fastener directly to the driver.
- For #2 - #10 fasteners, up to 1 inch long.
- Available for captive washer type screws (A-315V).
- Feed speed of up to 1 screw per second.
- System includes feeder, hose assembly, air screwdriver, and FRL.

## PRODUCTIVE

- Eliminates reaching for fasteners.
- Most jams are easily cleared on the line.
- Frees operator's hand for productive use.
- Large hopper holds between 1000-5000 fasteners.

## ERGONOMIC

- Eliminates manual handling of fasteners and shavings.
- Reduces workspace clutter.
- Keeps workspace clean of dropped fasteners.
- Torque reaction of standard driver is minimal and can be eliminated with optional Ergo-Arm®.

## RELIABLE

- Longest warranty in the industry — 3 years.
- Rocking Bar design only operates as needed.
- "Photo eyes" maximize motor life.
- Design eliminates burrs and shavings by minimal handling of the fastener.
- Durable head assembly lasts for years.
- There are more Acra-Feed® systems in use than any other system.



**A-2100**



**A-315V**

MODEL	APPLICABLE SCREWS	SCREW LENGTH in mm	HOPPER CAPACITY	MAX. FASTENING SPEED	WEIGHT lb	DIMENSIONS l x w x h (in)
A-2100	M2-M5 (#2 - #10)	1/4-1 6-25	1,500cc (1,000-5,000 pcs)*	60 screws/min*	68	7 x 17 x 16
A-315V	M2-M5 (#2 - #10)	1/4-1 6-25	450cc (500-2,500 pcs)*	60 screws/min*	74	10 x 21 x 16

\* Depends upon specific application

Delivery Hose: 10 ft

Air Pressure: 85 psi

Power: AC 110V, 20W, AC 220V by request

**HOW TO ORDER:** The Acra-Feed is custom configured to the work you will be doing. To properly set up the unit we need a sample of the work piece and approximately 200 of your fasteners. Once the samples are received a permanent file number is assigned to the application.

**LIMITED WARRANTY:** All Acra-Feed systems are warranted for a period of three years, on a one shift basis, against manufacturer's defects, or the amount recoverable under component manufacturer's warranties. This warranty does not cover misuse, abuse, accidental breakage, parts replacement due to normal wear, or tools altered by the end user or distributor.

# GRAVITY-DEFYING BALANCERS

## TW-SERIES BALANCERS

### TW-0 and TW-00

- Gravity defying / "true balance".
- No tension buildup to cause worker fatigue.
- Easy external direct drive tensioning.
- 360 degree upper swivel.
- 3.3 ft stranded steel cable 1/8" diameter (TW-00 cable length 18").
- Safety cable provision.
- Tool clip included.



**TW-0 & TW-00 Series**

MODEL	CAPACITY		Anti-Gravity Capacity (lbs)
TW-00	1.1- 3.3 lb	0.5-1.5 kg	2.5-3.0
TW-0	1.1- 3.3 lb	0.5-1.5 kg	2.5-3.0
TW-3	2.2- 6.6 lb	1.0-3.0 kg	4.5-6.0
TW-5	5.5-11.0 lb	2.5-5.0 kg	8.0-10.5
TW-9	9.9-19.8 lb	4.5-9.0 kg	15.0-19.0
TW-15	19.8-33.0 lb	9.0-15.0 kg	26.0-32.5
TW-22	33.0-48.4 lb	15-22 kg	41.0-48.0
TW-30	48.4-66.0 lb	22-30 kg	58.0-65.5
TW-40	66.0-88.0 lb	30-40 kg	77.5-87.5
TW-50	88.0-110.0 lb	40-50 kg	100.0-109.5
TW-60	110.0-132.0 lb	50-60 kg	122.0-131.0
TW-70	132.0-154.0 lb	60-70 kg	144.0-153.0



**TW-3 to TW-70 Series**

### TW-3 through TW-15

- Four (4) models supporting weights from 2.2 to 33 lb.
- Tapered drum allows "true balance" throughout cable travel.
- Easy external direct drive tensioning.
- Cast aluminum casing for durability.
- Permanent lubrication.
- 360 degree top swivel.
- 4.3 ft of 5/32" diameter stranded steel cable.
- Safety chain provision.
- Enclosed spiral spring for added safety.

### TW-22 through TW-70

- Six (6) models supporting weights from 33 to 154 lb.
- Tapered drum allows for "true balance".
- Cast aluminum housing.
- Easy external tensioning.
- Manual drum lock.
- 360 degree upper swivel.
- Permanent lubrication.
- 5 ft of stranded steel 3/16".
- Automatic Safety Lock.
- Enclosed spiral spring for added safety.

## ASB-SERIES BALANCERS

- Built-in Safety Features: The cable, drum, and enclosed spring are fully visible without opening the unit for easy and convenient safety checks. The sturdy spiral spring is enclosed for greater control and safety.
- Ergonomic Spring Release: The automatic safety lock provides extra control.
- Extended Cable Length: Stainless steel cables allow for extended reach on applications.
- Enhanced Gear Mechanism: Allows for more exact adjustment of tension.
- No Recoil and Low Resistance: Tapered drum style provides gravity defying tool positioning and low travel.

MODEL	CAPACITY		STROKE		WEIGHT	
ASB-0C	1.1 - 3.3 lb	0.5 - 1.5 kg	51.1 in	130 cm	1.5 lb	0.7 kg
ASB-3C	3.3 - 6.6 lb	1.5 - 3 kg	86.4 in	220 cm	3.0 lb	1.4 kg
ASB-5C	5.5 - 11 lb	2.5 - 5 kg	86.4 in	220 cm	3.4 lb	1.5 kg



**ASB-OC Gravity Defying and Hand Adjustable Balancer**



**ASB-3C & ASB-5C**

# LINE REEL BALANCERS / RETRACTORS

## LINE REEL BALANCERS

### LR-Series

- Designed for light duty applications with small pneumatic tools.
- Integrating air hose and support cable keep work areas clean.
- Adjustable ball stop for optional positioning.
- 1/4" I.D. polyvinyl hose with 1/4" NPT inlet.
- 360 degree upper swivel.
- Maximum 142 PSI

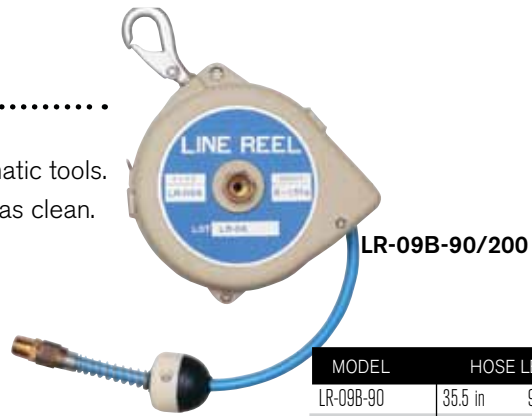

MODEL	HOSE LENGTH		CAPACITY	
LR-09B-90	35.5 in	90 cm	3 lb	1.5 kg
LR-09B-200	78.3 in	199 cm	3 lb	1.5 kg

## RETRACTORS

### RPA Series

- No tools needed to set tension.
- 5 ft nylon coated steel cable.
- Reinforced hanging bracket includes safety cable provision.
- Adjustable cable stop.
- Three (3) models support weight 0.5-5 lb.
- Tool clip included.

### RMA-L Series

- Steel housing with polyester finish.
- Reinforced hanging bracket includes safety cable provision.
- 8 ft of 3/32" diameter coated steel cable.
- Permanently lubricated.
- Tool clip included.
- External tension adjustment.
- Ratchet cable lock.



MODEL	CAPACITY	
RPA-1	0.5 - 1.5 lb	0.2 - 0.7 kg
RPA-2	1.5 - 3.0 lb	0.7 - 1.4 kg
RPA-3	3.0 - 5.0 lb	1.4 - 2.3 kg
RMA-7L	5 - 10 lb*	2.3 - 4.8 kg*
RMA-15L	10 - 15 lb*	4.5 - 6.8 kg*
RMA-20L	15 - 23 lb*	6.8 - 10.4 kg*

\* With ratchet lock

# ERGO-ARM® TOOL SUPPORT SYSTEMS

## FEATURES AND BENEFITS

- Ergonomic support for electric and pneumatic tools.
- Reduces operator fatigue.
- Increases productivity, consistency, and accuracy.



### PARALLEL ARM SERIES

AD-D1098-p, AD-D1098-pac, AD-D1098-pAce

- Minimizes operator control.
- Vertical adjustment eliminates cross-threading.
- Fixtured tool increases repeatability.
- Adjustable reach.
- Available in air or oil cylinder models.
- Electric tool mount standard on PACE model.



### SINGLE ARM SERIES

AD-D1098-S, AD-D1098-SAC

- Full tool rotation.
- Operator control.
- Adjustable reach.
- Compatible with automatic screw feeder.
- Available in air or oil cylinder models.

MODEL	ARM STYLE	TOOL MOUNT	REACH		CAPACITY		MAXIMUM TORQUE*	
			IN	MM	LB	KG	IN-LB	NM
<b>AIR CYLINDER SERIES</b>								
AD-D1098-SAC	Single	Air manifold	4 - 33	102 - 838	0 - 15	0 - 7	110	12
AD-D1098-PAC	Parallel	Air manifold	4 - 33	102 - 838	0 - 15	0 - 7	110	12
AD-D1098-PACE	Parallel	Electric	4 - 33	102 - 838	0 - 15	0 - 7	110	12
<b>OIL CYLINDER SERIES</b>								
AD-D1098-S	Single	Air manifold**	4 - 33	102 - 838	0 - 15	0 - 7	110	12
AD-D1098-P	Parallel	Air manifold	4 - 33	102 - 838	0 - 15	0 - 7	110	12

\* Max torque allowed may be dependent on tool clutch type and joint rate

\*\* For single arm electric tool mount, order EAP-202ED-KIT

## SPECIAL FEATURES OF CLASSIC STYLE ERGO-ARM®

Dual ball bearing joint construction for smoother movement and long life

Air regulator offers precision adjustment of resistance for perfect balance

Unique upper rail adjustment allows true vertical approach to any fastener - no cross-threading



# ERGO-ARM® ACCESSORIES AND LINEAR ARM

## ERGO-ARM® ACCESSORIES

- End-of-Arm Tooling options for the Ergo-Arm® allow you to choose the style right for your application.
- The tool holders permit the tool to swivel, rotate, swing, or twist. The heavy duty construction can lock out any single, or combination of rotating, actions allowing only the motions required by your application.
- End-of-Arm Tooling Brackets are simple to use, one Ergo-Arm® can be used for more than one application.

### FOR USE WITH MODELS AD-D1098-S/SAC



EAA-21 - Pistol Grip Tool Mount Kit



EAA-21 - Right Angle Tool Mount



EAP-202ED-KIT - Electric Driver Tool Mount Kit

### PARALLEL ARM KIT



EAA-04 - Provides easy conversion of the standard Ergo-Arms® to the parallel style.

### FOR USE WITH MODELS AD-D1098-P/PAC



EAP-203-ASSY - Air Manifold Tool Mount Kit (Standard on parallel units)



EAP-202ASSY - Driver Tool Mount

## LINEAR ARM

- Smooth movement and perfect balance while limiting operator control.
- Machined stainless steel and ball bearing construction.
- Two high quality tool balancers are included with each arm to provide a wide range of adjustment.



LQ-0002 Linear Arm  
shipped with two ASB-0C balancers

LQ-0004 Linear Arm  
shipped with two TW-3 balancers

LQ-0024H Heavy Duty Arm  
shipped with two TW-3 balancers

MODEL	DESCRIPTION	MAX. REACH		WEIGHT CAPACITY		MAX. TORQUE		HEIGHT		STANDARD TOOL MOUNT DIAMETER	
		IN	CM	LB	KG	FT-LB	NM	IN	CM	IN	CM
LQ-0002	Linear Arm	14	37	1 - 5	0.5 - 2.3	20	27	24	61	1.6	4.1
LQ-0004	Linear Arm	23	58	3 - 10	1.4 - 4.5	25	34	36	91.4	1.6	4.1
LQ-0024H	Heavy Duty Arm	23	58	3 - 10	1.4 - 4.5	75	102	36	91.4	1.6	4.1

## CUSTOM REACTION DEVICES

- Torque Tubes with up to 300 ft-lb capacity.
- Torque Arms with up to 3,000 ft-lb capacity.
- Floor, table, wall, and overhead mounting available.
- Multiple pivot-points allow reach up to 15 feet.



Contact your AIMCO sales representative in order to determine the exact torque reaction system needed to improve the productivity and ergonomics of your assembly station!

# CARBON TORQUE ARMS

## CARBON TORQUE ARMS

- With the Carbon Torque Arm, the assembly operation will be smooth and comfortable since the arm is absorbing the torque reaction generated by the tool.
- The Carbon Arm are ergonomics and easy to use, thanks to the telescopic design which allow maximum freedom of movement and flexibility.
- Extremely durable and require no maintenance.



PART #	MAX TORQUE NM	MIN. LENGHT MM	MAX LENGHT MM
CLL10-1000	10	500	1,000
CLR55-1230	55	570	1,230
CLR55-2000	55	760	1,800
CLR55-2500	55	970	2,430
CLR100-1230	100	570	1,230
CLR100-2000	100	760	1,800
CLR100-2500	100	970	2,430
CLR150-1230	150	570	1,230
CLR150-2000	150	760	1,800
CLR150-2500	150	970	2,430
CLR2201230	220	570	1,230
CLR220-2000	220	760	1,800
CLR220-2500	220	970	2,430

## TOOL HOLDERS

PART #	DESCRIPTION
CLR55-110P	Pistol Mount CLR55
CLR55-110PQ	Pistol Mount , Quick Change CLR55
CLR55-110A	Angle Mount CLR55
CLR55-110AQ	Angle Mount, Quick Change CLR55
CLR55-110AS	Angle Mount, Swivel CLR55
CLR100-200P	Pistol Mount CLR100
CLR100-200PQ	Pistol Mount, Quick Change CLR100
CLR100-200A	Angle Mount CLR100
CLR100-200AQ	Angle Mount, Quick Change CLR100
CLR100-200AS	Angle Mount, Swivel CLR100
CLR220-300P	Pistol Mount CLR160/220
CLR220-300PQ	Pistol Mount, Quick Change CLR160/220
CLR220-300A	Angle Mount CLR160/220
CLR220-300AQ	Angle Mount,Quick Change CLR160/220
CLR220-300AS	Angle Mount,Swivel CLR160/220

# WORKSTATION COMPONENTS AND ASSEMBLIES

## COMPONENTS

### TRACK

Steel with beige polyester finish. Use for vertical and horizontal workstation support.

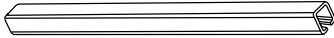

PART NUMBER	30# TRACK
AT3-3	3 ft track
AT3-4	4 ft track
AT3-6	6 ft track
AT3-9*	9 ft track

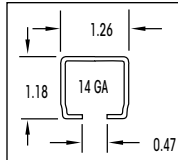

PART NUMBER	50# TRACK
AT5-3	3 ft track
AT5-4	4 ft track
AT5-6	6 ft track
AT5-9*	9 ft track
AT5-12*	12 ft track

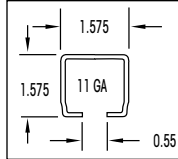

### TRACK NUT (ATN-3/5)

Zinc plated steel. Use to attach accessories to track, as end stops, or to isolate rolling accessories. Fits both 50 lb. and 30 lb. track.



### END STOP (AES-3/5)

Zinc oxide finish. Use to prevent balancer trolley from "overtraveling" the horizontal track.

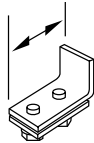

### MOUNTING PLATE (AMP-5)

Black polyester finish. Use as a base to mount vertical uprights.

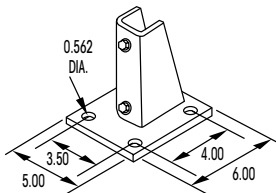

### END CAP (AEP-3/5)

Black molded vinyl. Use to cap track ends for a professional finish.

- AEP-3 for 30 lb. track
- AEP-5 for 50 lb. track

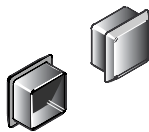

### ANGLE BRACKET (AB-3/5)

Black polyester finish. Use to mount horizontal track to vertical track. Fits both 50 lb. and 30 lb. track.

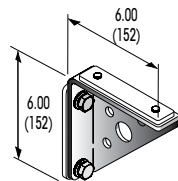

### JOINT HANGER BRACKET (AJH-3/5)

Black polyester finish. Use to couple and hang end-to-end track.

- AJH - 3 for 30 lb. track
- AJH - 5 for 50 lb. track

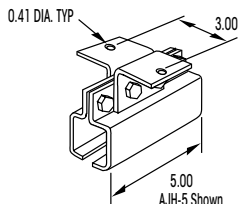

### BALANCER TROLLEY (ABT-3/5)

Black polyester finish. Use as moving support for tool balancers, hose, and cable. Quality ball bearing wheels for long life and smooth tracking.

- ABT-3 for 30 lb track (1.00 dia)
- ABT-5 for 50 lb track (1.25 dia)

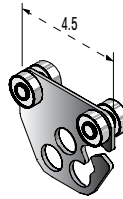

### HANGER BRACKET (AHB-3/5)

Black polyester finish. Use to suspend track at right angle.

- AHB-3 for 30 lb. track
- AHB-5 for 50 lb. track

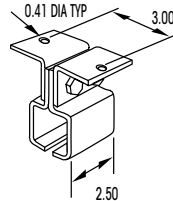

### VERTICAL COLUMN (AVC-5\*)

Beige polyester finish, 3" diameter x 9 ft upright steel column with welded base. Use as floor mount for extra stability with jibs or workstation components.

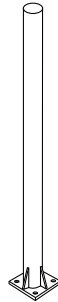

### INTERMEDIATE CARRIER

Black polyester finish. Use for moving cable or hose festoon. Supports hose cable OD .60-.94.

- AIC3-2 for 30 lb. track
- AIC5-2 for 50 lb. track

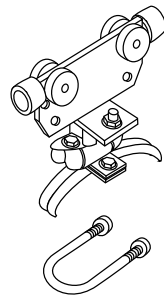

### U-BOLTS (AUB-5)

Zinc plated steel. Use to secure boom bracket, or any flat metal plate, to AVC-5 (sold individually).

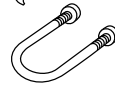

### END CLAMP (AEC5-2)

Black polyester finish. Use as end stop with hose carrier for festoon. Cable/hose OD .60-.94.

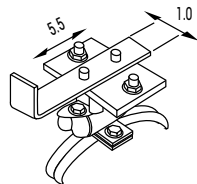

### SUPPORT CLAMPS (ASC-3/5)

Black polyester finish. Use as additional support for track.

- ASC-3 for 30 lb. track
- ASC-5 for 50 lb. track

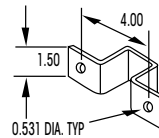

### TOOL CLIP (SH-5)

Steel clip with safety latch. Use for tool attachment and as replacement clip for lightweight tool balancers. Measures 2.37" long.



### ROLLING HANGER (ABT5-R)

Black polyester finish. Use as support for rolling track. Allows X/Y axis movement, includes ball bearing wheels.

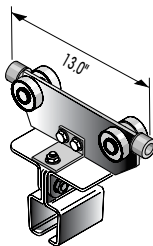

### 90° CONNECTOR FOR 3/8" HOSE (WSCH)

3/8" I.D. Brass. Use to provide stable transfer point from air line to tool. 90 degree connector attaches to ABT-5.

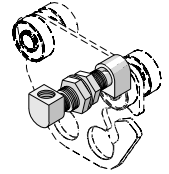

## WALL AND FLOOR MOUNTED JIBS

### 3 FT. SWINGING JIB (AW3S)

### 3 FT FIXED JIB (AW3F)

### 3 FT. SWINGING JIB FOR CHANNEL MOUNT (AJS3\*\*)

Jibs are mounted to wall or beams to create free standing workstations. End stop, end cap, and balancer trolley included. Maximum weight: 30 lb.

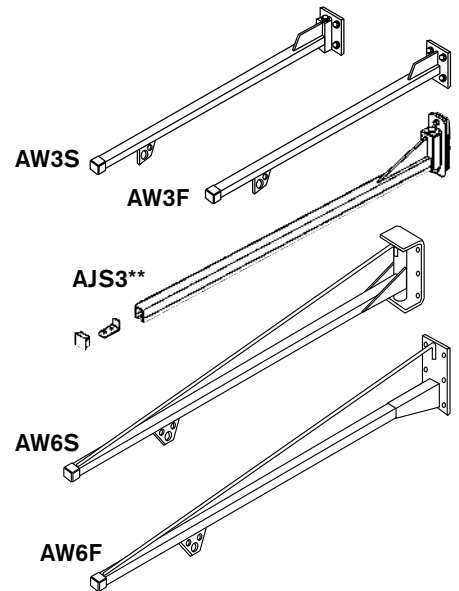

### 6 FT. SWINGING JIB (AW6S)

### 6 FT FIXED JIB (AW6F)

Jibs can be wall mounted or attached to vertical column (AVC-5) to create a freestanding workstation. End stop, end caps, and balancer trolley are included. Maximum weight: 50 lbs.

All complete assemblies are beige polyester finish and include balancer trolley, end caps, and end stops. Floor mounted assemblies are not able to ship via UPS.

### When choosing a workstation system, remember...

Total weight capacities should include tool balancer, hose/cable, and tool/fixture. Units need to be supported vertically and horizontally every 6 ft.

- \* Additional freight may apply
- \*\* AJS3 Does not include balancer trolley

# WORKSTATION COMPONENTS AND ASSEMBLIES

**FLOOR MOUNTED  
3 FT. SWINGING JIB  
(AW3FMS)**

**FLOOR MOUNTED  
3 FT. FIXED JIB  
(AW3FMF)**  
Maximum weight: 30 lb  
Column height: 6 ft

**FLOOR MOUNTED  
6 FT. SWINGING JIB  
(AW6FMS\*)**

**FLOOR MOUNTED  
6 FT. FIXED JIB  
(AW6FMF\*)**  
Maximum weight: 50 lb  
Column height: 9 ft

Units include end stop,  
balancer trolley and intermediate carrier.

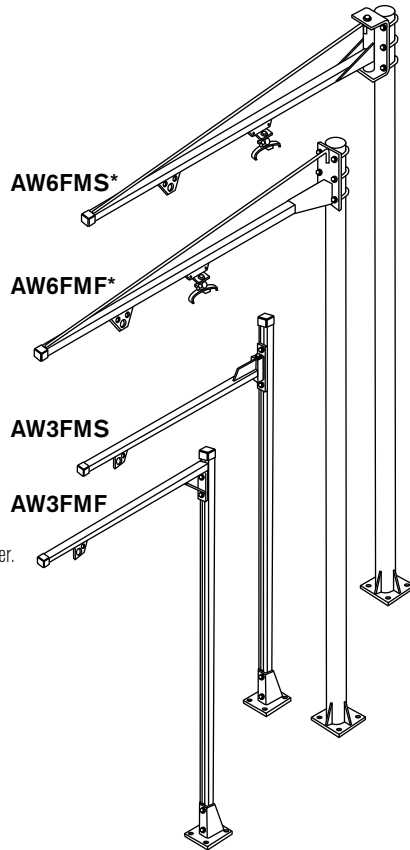

## AIMCO TOOL SUPPORT ARMS

**BENCH MOUNTED SWINGING JIB (JJ30-S)  
BENCH MOUNTED FIXED JIB (JJ30)**

- 30 lb maximum weight
- 48" column height including mounting plate
- 3 ft. swinging jib includes balancer trolley, end stop and cap

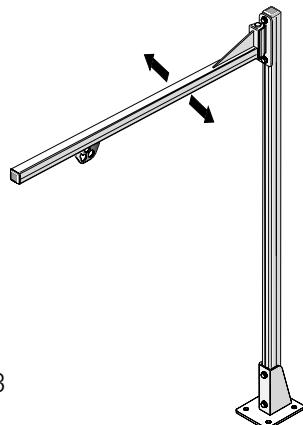

**BENCH MOUNTED WORKSTATION  
WITH TORQUE ARM (JJ30-TA\*\*)**

- 5 lb. maximum weight (RPA-3 included)
- 5' column height including mounting plate
- 38" jib length (swinging)
- 15 ft-lb torque rating
- 3/8" NPT inlet
- 1/4" NPT outlet
- Beige polyester finish
- 1/4" braided air hose
- 21" maximum vertical arm travel

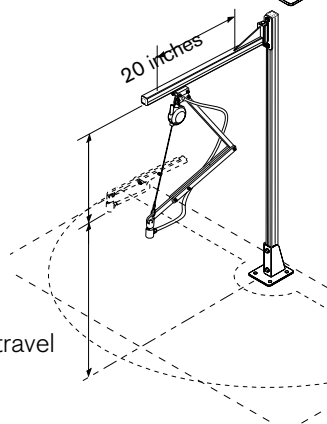

\*\*Additional freight may apply

\*\*For use with pneumatic tools only

## CREATE A CUSTOM SUPPORT SYSTEM USING AIMCO'S QUALITY PRODUCTS

- Organize work areas to create a safe, productive working environment.
- Reduce risk of injury to assembler by providing support for heavy tools.
- Protect valuable tools, fixtures, and monitoring devices from damage by suspending them out of the way.



AIMCO BASIC WORKSTATION KIT (ATW-50)

- 50 lb maximum weight capacity
- 48" uprights
- 36" extensions
- Table mounts included
- 6' tool rail with rolling trolley included
- All necessary hardware included

**TROLLEY MOUNTED TORQUE ARM  
WITH 3-LB RETRACTOR AND HOSE  
(FA-50-2\*)**

Ergonomic arm absorbs torque reaction. Moves front to back along overhead jib.

**(TA-50-2)**  
Moves side to side on overhead track.



**TOOL BASKET (21226)**

Mounts easily to any work area to hold pistol and angle style tools.



**AIMCO can customize a workstation for you.  
Contact your AIMCO sales representative.**

# AIR PREPARATION UNITS

## FEATURES AND BENEFITS

- All models include L-mount bracket, gauge, and metal bowl shields.
- Polycarbonate filter and lubricator bowls (metal bowls standard on AFRL-8).
- 25-micron filter included on all models.
- Regulating range: 7 – 125 PSI
- Custom order upgrade items include metal bowl, 5 micron filter, semi-automatic filter drain, and reduced PSI range regulator. Contact an AIMCO sales representative for more information.



AFRL-3



AFRL-2-C

MODEL	PORT	GAUGE PORT	FLOW RATE	BOWL SHIELD	
AFRL-2	1/4"	1/8"	70	2,000	yes
AFRL-2-C	1/4"	1/8"	60	1,700	yes
AFRL-3	3/8"	1/4"	140	4,000	yes
AFRL-3-C	3/8"	1/4"	105	3,000	yes
AFRL-4	1/2"	1/4"	140	4,000	yes
AFRL-8	1"	1/4"	180	5,000	yes

DIM.	AFRL-2	AFRL-2-C	AFRL-3	AFRL-3-C	AFRL-4	AFRL-8
H	6.16 (156.5)	8.31 (211.1)	7.54 (191.5)	10.31 (261.9)	7.54 (191.5)	10.69 (271.5)
HB	1.39 (35.3)	1.38 (35.1)	1.57 (40.0)	1.57 (39.9)	1.57 (40.0)	1.97 (50.0)
HS	1.50 (38.1)	3.64 (92.5)	1.61 (40.9)	4.41 (112.0)	1.61 (40.9)	1.89 (48.0)
L	7.13 (181.1)	4.61 (117.1)	9.37 (238.0)	6.06 (153.9)	9.37 (238.0)	11.81 (300.0)
LS	2.52 (64.0)	2.30 (58.4)	3.31 (84.1)	3.03 (77.0)	3.31 (84.1)	4.13 (104.9)
TB	1.61 (41.0)	1.61 (40.9)	1.97 (50.0)	1.97 (50.0)	1.97 (50.0)	2.75 (69.9)
TG	2.39 (60.7)	2.39 (60.7)	2.58 (65.5)	2.58 (65.5)	2.58 (65.5)	2.97 (75.4)
TR	2.09 (53.1)	2.09 (53.1)	2.76 (70.1)	2.76 (70.1)	2.76 (70.1)	3.54 (89.9)

The supply of clean, dry air is essential to the operation of pneumatic powered tools. Use only clean filtered air for longer tool life. Provide proper airflow (CFM) and regulate air pressure (PSI) for optimum performance.

## AIR PREPARATION UNITS: BASIC FUNCTIONS

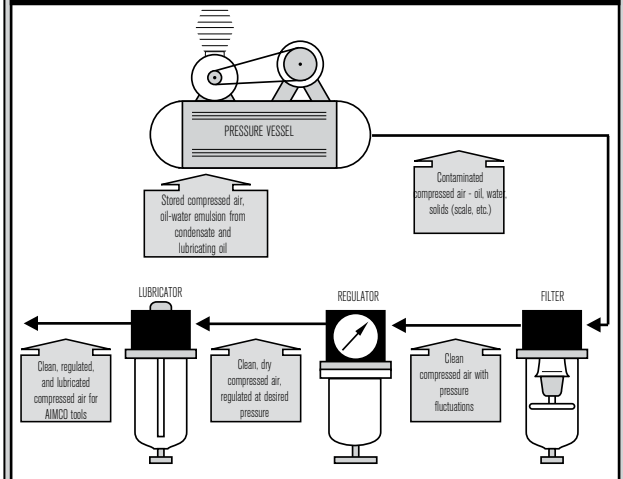

To determine unit size for application, you will need to know:

- Total air flow (CFM) required for application.
- Size of incoming air line.
- Size of air line required by tool.
- Air supply pressure (PSI).
- Allowable pressure drop.
- Does the application requires lubrication?
- Does the overall system have the required capacity?

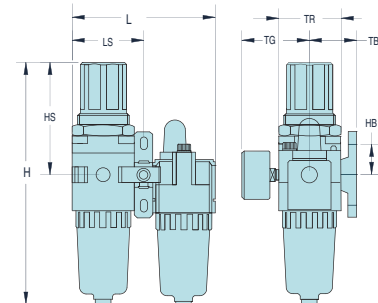

AFRL-2-C  
AFRL-3-C

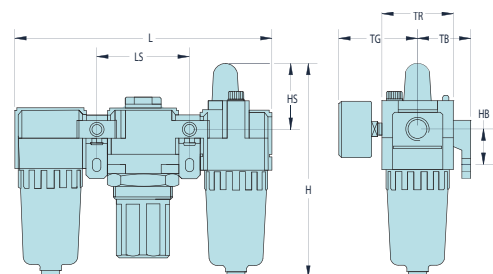

AFRL-2  
AFRL-3  
AFRL-4  
AFRL-8

# AIR LINE

## AIMCO AIR HOSE

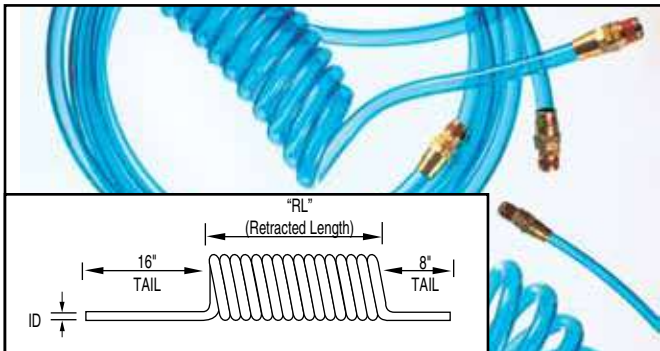

- Durable Polyurethane Hose.
- Excellent Recoil Memory.
- Maximum Flexibility and Lightweight.
- Transparent Hose Color (opaque available).
- Custom Colors Available.
- High Chemical Resistance.

## SINGLE AIR HOSE ASSEMBLIES (COILED)

MODEL	WORKING PRESSURE 100PSI	DESCRIPTION (OD X ID X LENGTH)	RETRACTED LENGTH	NPT FITTINGS
ASH-250C-10MSZ		3/8" x 1/4" x 10'	7"	1/4"
ASH-250C-15MSZ		3/8" x 1/4" x 15'	9 1/2"	1/4"
ASH-250C-25MSZ		3/8" x 1/4" x 25'	15 1/2"	1/4"
ASH-375C-15MSZ		9/16" x 3/8" x 15'	10"	3/8"
ASH-375C-25MSZ		9/16" x 3/8" x 25'	14"	3/8"
ASH-500C-15MSZ		3/4" x 1/2" x 15'	13"	1/2"
ASH-500C-25MSZ		3/4" x 1/2" x 25'	23"	1/2"

## SINGLE AIR HOSE (COILED) CUSTOM LENGTHS

Custom length coil assemblies and special colors are available in minimum order quantities.

## STRAIGHT AIR HOSE (SOLD PER FOOT)

MODEL	DESCRIPTION
ASH-250Z	1/4" I.D.
ASH-375Z	3/8" I.D.
ASH-500Z	1/2" I.D.

- Assemblies include reusable swivel fitting.
- Burst pressure 428 PSI @ 68° F.
- Working temperature: -104° F to 175° F.
- Straight hose is available by the foot with, or without, hose fittings.
- Ask about full reel pricing.

## AIR HOSE FITTINGS

MODEL	CAPACITY
250-RZ	1/4" NPT Rigid Fitting
250-SZ	1/4" NPT Swivel Fitting
375-RZ	3/8" NPT Rigid Fitting
375-SZ	3/8" NPT Swivel Fitting
500-RZ	1/2" NPT Rigid Fitting
500-SZ	1/2" NPT Swivel Fitting

## HELPFUL HINTS FOR AIR HOSE USE:

- Use recommended ID air hose and fittings.
- Replace air hose regularly to help maintain clean air.
- A clear hose allows you to see water or dirt accumulation in hose.
- Use correct length of hose to reduce air loss and pressure drop.
- Use locking quick disconnect couplers for additional safety.

## ERGONOMIC TWIST PLUGS

These unique, ergonomically designed hose fittings provide 360° rotation and 35° angled rotation in any direction.



MODEL	DESCRIPTION
TS-20NP-3NPT	1/4" NPT Female x 3/8" NPT Male
TS-30NP-2NPT	3/8" NPT Female x 1/4" NPT Male
TS-20NP-2NPT	1/4" NPT Female x 1/4" NPT Male
TS-20US-2NPT	1/4" US Plug x 1/4" NPT Male
TS-20US-3NPT	1/4" US Plug x 3/8" NPT Male
TS-30US-2NPT	3/8" US Plug x 1/4" NPT Male
TS-30US-3NPT	3/8" US Plug x 3/8" NPT Male

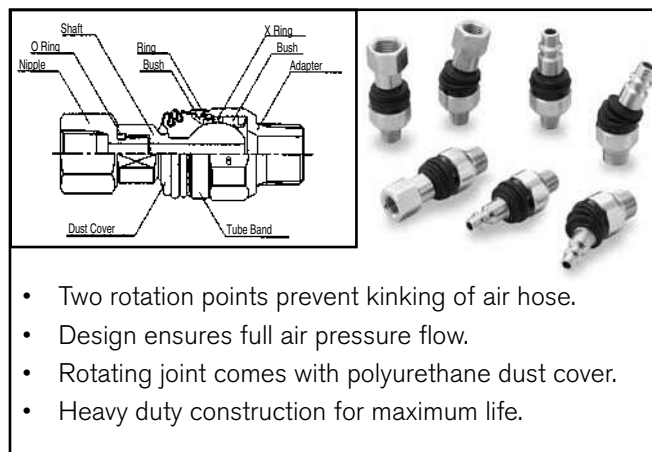

- Two rotation points prevent kinking of air hose.
- Design ensures full air pressure flow.
- Rotating joint comes with polyurethane dust cover.
- Heavy duty construction for maximum life.

## QUICK COUPLERS

Manual ball couplers designed for use with ergonomic twist plugs. Brass with nitrile seals, rated to 300 PSI, from -40° to +250° F.



MODEL	DESCRIPTION
B23	1/4" NPT F x 1/4" QC Brass Coupler
B23E	1/4" NPT F x 3/8" QC Brass Coupler
B25	3/8" NPT F x 3/8" QC Brass Coupler

# AIR LINE ACCESSORIES

## IN-LINE MINI LUBRICATORS

These mist type inline lubricators keep air operated tools performing with greater efficiency. The patented "on the tool" mist lubricator system is more cost effective.



MODEL	DESCRIPTION	WEIGHT	LENGTH	NPT	TOOL CFM
7006	Mini Lube	2 1/2 oz	2 1/4	1/4	3 - 7
7007	Midget Lube	3 1/2 oz	2 1/2	1/4	7 - 15
7008	Master Lube	5 oz	3 1/4	3/8	15 - 30

## IN-LINE MINI REGULATORS

Easily adjust airflow with the turn of a dial.



MODEL	CAPACITY
932-100-0	1/8" NPT
932-110-0A	1/4" NPT

## SWIVEL AIR FITTINGS GAUGES

For use with most portable air tools, including screwdrivers, drills, grinders, sanders, buffers, staple guns, and more. Rotates 360° for awkward angles.



MODEL	INLET	WEIGHT	MAX PSI	TOOL CFM
7021	1/4" NPT	3 oz	Up to 125	25
7021AG	1/4" NPT	3 oz	Up to 125	25
7041A	3/8" NPT	11 oz	Up to 125	50
7041AG	3/8" NPT	3 oz	Up to 125	50
7051	1/2" NPT	7 oz	Up to 125	60

## FITTINGS AND ADAPTERS

Brass pipe fittings for use as medium and low pressure connectors. Meets functional requirements of SAE J530, SAE J531, ASME and ASA. Rated 1,000 PSI from -65° to +250° F.



MODEL	DESCRIPTION
222P-6-4	3/8 NPT F x 1/4 NPT M Adapter
222P-8-6	1/2 NPT F x 3/8 NPT M Adapter
222P-12-8	3/4 NPT F x 1/2 NPT M Adapter
208P-6-4	1/4 NPT F x 3/8 NPT M Bushing
208P-8-6	3/8 NPT F x 1/2 NPT M Bushing

## MINI AIR GAUGE SWIVEL JOINT KITS

- Bi-directional 360° rotation.
- Keeps air hose straight and untwisted.
- Decreases operator fatigue.



MODEL	DESCRIPTION
7021AG	1/4 PT/NPT
7041AG	3/8 PT/NPT

# STANDARD FASTENER TOOLS

## STANDARD FASTENER TOOLS

Connect your tool to the application with Bits, Sockets and Nutsetters from AIMCO.

AIMCO has assembled the most complete package of commonly used screwdriver bits and nutsetters in the industry. Our goal is to supply you with the highest quality bits and nutsetters for all your fastener needs. If you're in electronics, aerospace, automotive, or general industry, AIMCO has the bits and nutsetters to fit your needs.

## IMPACT SOCKETS

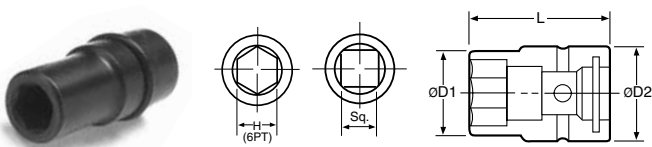

Part No	Hex	D1 mm	D1 in	D2 mm	D2 in	L mm	L in
---------	-----	----------	----------	----------	----------	---------	---------

### 3/8" Square Drive

SAE	METRIC	Part No	Hex	D1 mm	D1 in	D2 mm	D2 in	L mm	L in
		A31/4	1/4"	10	0.39	19	0.75	34	1.34
		A35/16	5/16"	12	0.47	19	0.75	34	1.34
		A33/8	3/8"	15	0.59	19	0.75	34	1.34
		A306	6 mm	10	0.39	19	0.75	34	1.34
		A307	7 mm	13	0.49	20	0.79	32	1.26
		A308	8 mm	14	0.55	20	0.79	32	1.26

### 3/8" Square Drive, Deep

A307-2	7 mm	13	0.49	20	0.79	50	1.97
A307-2.75	7 mm	13	0.49	20	0.79	70	2.76
A308-2	8 mm	14	0.55	20	0.79	50	1.97

### 3/8" Square Drive, Magnetic

SAE	METRIC	Part No	Hex	D1 mm	D1 in	D2 mm	D2 in	L mm	L in
		A31/4MP	1/4"	10	0.39	19	0.75	34	1.34
		A35/16MP	5/16"	12	0.47	19	0.75	34	1.34
		A33/8MP	3/8"	15	0.59	19	0.75	34	1.34
		A308MP	8 mm	14	0.55	20	0.79	32	1.26
		A310MP	10 mm	17	0.65	20	0.79	32	1.26
		A311MP	11 mm	17	0.65	19	0.75	34	1.34

### 1/2" Square Drive

SAE	METRIC	Part No	Hex	D1 mm	D1 in	D2 mm	D2 in	L mm	L in
		A43/8	3/8"	16	0.63	25	0.98	38	1.50
		A47/16	7/16"	18	0.69	25	0.98	38	1.50
		A41/2	1/2"	19	0.75	25	0.98	50	1.97
		A408	8 mm	16	0.61	25	0.98	40	1.58
		A409	9 mm	16	0.63	25	0.98	40	1.58
		A410	10 mm	18	0.69	25	0.98	40	1.58

### 1/2" Square Drive, Deep

A43/8-3.25	3/8"	17	0.67	25	0.98	82	3.23
A47/16-3.25	7/16"	19	0.73	25	0.98	82	3.23
A41/2-3.25	1/2"	22	0.85	25	0.98	82	3.23
A410-2	10 mm	18	0.69	25	0.98	50	1.97
A410-3	10 mm	18	0.69	25	0.98	75	2.95
A410-3.25	10 mm	17	0.67	25	0.98	82	3.23
A411-3.25	11 mm	19	0.73	25	0.98	82	3.23

Part No	Hex	D1 mm	D1 in	D2 mm	D2 in	L mm	L in
---------	-----	----------	----------	----------	----------	---------	---------

### 1/2" Square Drive, Magnetic

A408MP	8 mm	16	0.61	25	0.98	40	1.58
A410MP	10 mm	18	0.69	25	0.98	40	1.58
A412MP	12 mm	21	0.81	25	0.98	40	1.58

### 3/4" Square Drive

SAE	METRIC	Part No	Hex	D1 mm	D1 in	D2 mm	D2 in	L mm	L in
		A611/16	11/16"	30	1.18	44	1.73	50	1.97
		A63/4	3/4"	32	1.26	44	1.73	50	1.97
		A613/16	13/16"	35	1.38	44	1.73	50	1.97
		A614	14 mm	24	0.95	38	1.50	55	2.17
		A616	16 mm	27	1.06	44	1.73	50	1.97
		A617	17 mm	30	1.18	38	1.50	55	2.17

### 3/4" Square Drive, Deep

SAE	METRIC	Part No	Hex	D1 mm	D1 in	D2 mm	D2 in	L mm	L in
		A611/16-4	11/16"	31	1.22	44	1.73	100	3.94
		A63/4-4	3/4"	33	1.30	44	1.73	100	3.94
		A613/16-4	13/16"	36	1.42	44	1.73	100	3.94
		A617-4	17 mm	31	1.22	44	1.73	100	3.94
		A618-4	18 mm	32	1.26	44	1.73	100	3.94
		A619-4	19 mm	33	1.30	38	1.50	100	3.94

### 1" Square Drive

SAE	METRIC	Part No	Hex	D1 mm	D1 in	D2 mm	D2 in	L mm	L in
		A87/8	7/8"	37	1.46	54	2.13	59	2.32
		A815/16	15/16"	38	1.50	54	2.13	59	2.32
		A81	1"	41	1.61	54	2.13	59	2.32
		A817	17 mm	31	1.22	50	1.97	63	2.48
		A819	19 mm	33	1.30	50	1.97	63	2.48
		A821	21 mm	37	1.46	50	1.97	63	2.48

## QUICK CHANGE CHUCKS

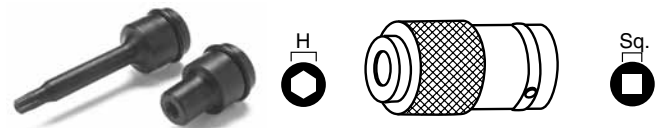

Part No	Sq Drive	Hex	D1 mm	D1 in	L mm	L in
---------	-------------	-----	----------	----------	---------	---------

ADC-2S	1/4"	1/4"	19	0.75	38	1.50
ADC-3S	3/8"	1/4"	20	0.79	42	1.65
ADC-4S	1/2"	1/4"	19	0.75	46	1.81
ADC-3SH7/16	3/8"	7/16"	25	0.98	46	1.81
ADC-4SH7/16	1/2"	7/16"	33	1.30	55	2.17

## ALLEN SOCKETS

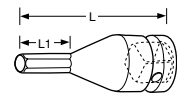

Part No	Hex	L1 mm	L1 in	L mm	L in
---------	-----	----------	----------	---------	---------

### 3/8" Square Drive

A31/4C	1/4"	10	0.39	42	1.65
A304C	4 mm	10	0.39	42	1.65

### 1/2" Square Drive

A41/4C	1/4"	25	0.98	50	1.97
A405C	5 mm	25	0.98	50	1.97

Additional types and sizes of fastener tools are available upon request.



# STANDARD FASTENER TOOLS

## EXTENSIONS

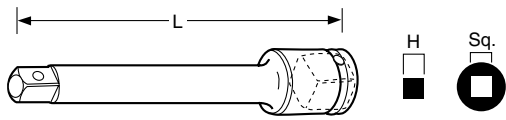

Part No	Square Drive	Hex	L mm	L in	D mm	D in
A375E	3/8"	3/8"	75	2.95	20	0.79
A405E	1/2"	1/2"	51	2.01	30	1.18
A610E	3/4"	3/4"	100	3.94	44	1.73
A810E	1"	1"	102	4.02	54	2.13
A1220E	1-1/4"	1-1/4"	200	7.87	60	2.36
A1418E	1-1/2"	1-1/2"	178	7.01	84	3.31
A2426E	2-1/2"	2-1/2"	264	10.39	137	5.39

## BIT HOLDERS



Part No	L mm	L in
1/4" Hex, Magnetic		
A3BHM-3	75	2.94
A3BHM-4	100	3.94
A3BHM-6	150	5.91
A3BHM-8	200	7.87
A3BHM-10	250	9.84

## SOCKET ADAPTERS



Part No	Female Sq. Drive	Male Sq. Drive	D mm	D in	L mm	L in
A302A	3/8"	1/4"	22	0.87	35	1.38
A403A	1/2"	3/8"	25	0.98	37	1.46
A504A	5/8"	1/2"	35	1.38	47	1.46
A604A	3/4"	1/2"	38	1.50	53	2.09
A806A	1"	3/4"	50	1.97	70	2.76
A128A	1-1/4"	1"	60	2.36	76	2.99
A#508A	Spline #5	1"	60	2.36	90	3.54

## UNIVERSAL SOCKETS



Part No	Hex	D1 mm	D1 in	D2 mm	D2 in	L mm	L in
3/8" Square Drive							
A310U	10 mm	16	0.63	20	0.79	55	2.17
A311U	11 mm	16	0.63	20	0.79	60	2.36
1/2" Square Drive							
A412U	12 mm	20.5	0.81	25	0.98	70	2.76
A413U	13 mm	19	0.75	24	0.95	70	2.76

## Description of Bits and Nutsetters Part Number Nomenclature

### Precedes Part Number

#### BITS

A3S	= Phillips® Power Drive
A3W	= Double Ended Phillips®
A38S	= Phillips® Insert
A39S	= Phillips® Insert Reduced Nose
A3M	= Slotted Power Drive
A38M	= Slotted Insert
A3MT	= Slotted Power Drive Reduced Nose
A3C	= Allen Socket Head Power Drive
A38C	= Allen Socket Head Insert
A3R	= Square Recess Power Drive
A3RT	= Square Recess Turned Down (Power)
A38R	= Square Recess Insert
A3T	= Torx® Power Drive
A38T	= Torx® Insert
A3TS	= Torq-Set® Power Drive
A38TS	= Torq-Set® Insert
A3TA	= Triangle Power Drive
A3TW	= Tri-Wing® Power Drive
A38TW	= Tri-Wing® Insert
A7	= 7/16 Power Drive
AS	= Electric Type Phillips®

#### BITS (Cont.)

AM	= Electric Type Slotted
ATW	= Electric Type Tri-Wing®
AT	= Electric Hios Type Torx®
A26S	= Electric Driver Phillips®
A26M	= Electric Driver Slotted
A26C	= Electric Driver Allen Socket Head
A3BHM	= Insert Bit Holder (Magnetic Type)
A3BHD	= Insert Bit Holder (Non Magnetic)

#### NUTSETTERS

A3B	= Nutsetter
A3BMP	= Magnetic (MP) Pressed Type
A3BMS	= Magnetic (MS) Spring Loaded
A3BMT	= Magnetic (MT) Tube Type
A3BU	= Universal Nutsetter

#### MAG-O-NETS

AM	= AIMCO Mag-O-Net®
----	--------------------

### Contained Within Part Number

#### BITS

PZ	= Pozidriv®
PZACR	= Pozidriv® ACR®
SDV	= Supadriv®
TR	= Torx® Tamper Resistant
ACRI	= ACR® Installation
ACR	= ACR® Remove
ACRB	= ACR® 4x4 Both Install and Remove
E4	= Electric 4mm diameter
E5	= Electric 5mm diameter
RS	= Reduced Shank

Additional types and sizes of fastener tools are available upon request.

# STANDARD FASTENER TOOLS

## PHILLIPS POWER BITS

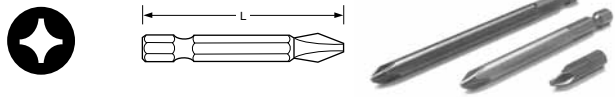

Part No	Point Size	L mm	L in
A3S0-2	0	50	1.97
A3S1-2	1	50	1.97
A3S1-2.75	1	70	2.76
A3S1-3	1	75	2.95
A3S1-3.5	1	90	3.54
A3S1-4	1	100	3.94
A3S1-6	1	150	5.91
A3S2-1.2	2	30	1.18
A3S2-1.6	2	40	1.57
A3S3-2	3	50	1.97
A3S3-2.75	3	70	2.76

### Double-Ended

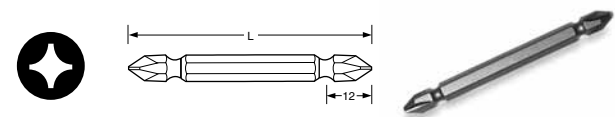

A3W1-3	1	75	2.94
A3W1-4	1	100	3.94
A3W2-2	2	50	1.97
A3W2-3	2	75	2.94
A3W2-4	2	100	3.94
A3W2-6	2	150	5.91
A3W2-8	2	200	7.87
A3W2-10	2	250	9.84
A3W2-12	2	300	11.81
A3W3-2	3	50	1.97
A3W3-3	3	75	2.94
A3W3-4	3	100	3.94
A3W3-6	3	150	5.91
A3W3-8	3	200	7.87

## TORX POWER BITS

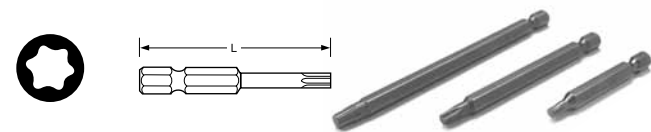

Part No	Torx Size	L mm	L in
A3T6-2	T6	50	1.97
A3T7-2	T7	50	1.97
A3T7-2.75	T7	70	2.76
A3T7-3.5	T7	90	3.54
A3T7-6	T7	150	5.91
A3T8-2	T8	50	1.97
A3T9-2.75	T9	70	2.76

## NUTSETTERS



Part No	Hex	L mm	L in
A3B1/4-2	1/4"	50	1.97
A3B1/4-2.5	1/4"	63	2.50
A3B5/16-2	5/16"	50	1.97
A3B5/16-2.5	5/16"	63	2.50
A3B3/8-2	3/8"	50	1.97
A3B3/8-2.5	3/8"	63	2.50
A3B05-2.75	5 mm	70	2.76
A3B55-1.2	5.5 mm	30	1.18
A3B55-2.75	5.5 mm	70	2.76
A3B55-4	5.5 mm	100	3.94
A3B06-2.75	6 mm	70	2.76
A3B07-1.2	7 mm	30	1.18
A3B07-2	7 mm	50	1.97
A3B07-2.75	7 mm	70	2.76
A3B07-4	7 mm	100	3.94
A3B08-1.2	8 mm	30	1.18
A3B08-2	8 mm	50	1.97
A3B08-2.75	8 mm	70	2.76
A3B08-4	8 mm	100	3.94
A3B08-6	8 mm	150	5.91
A3B08-8	8 mm	200	7.87
A3B09-2.75	9 mm	70	2.76
A3B09-4	9 mm	100	3.94
A3B10-1.2	10 mm	30	1.18
A3B10-2	10 mm	50	1.97
A3B10-2.75	10 mm	70	2.76
A3B11-2.75	11 mm	70	2.76
A3B12-1.2	12 mm	30	1.18
A3B13-2.75	13 mm	70	2.76
A3B14-2.75	14 mm	70	2.76
A3B16-2.75	16 mm	70	2.76
A3B17-2.75	17 mm	70	2.76

## MAG-O-NETS®\*

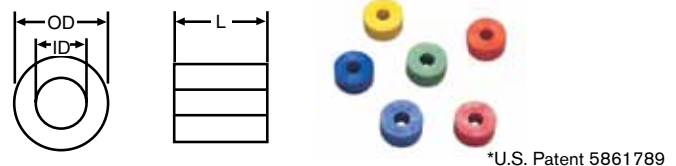

\*U.S. Patent 5861789

Part No	Torx Size	L mm	L in
AM1/4Z	7 MM	19 MM	10 MM
AM5Z	6 MM	17.5 MM	10 MM
AM3/16Z	3/16	17.5 MM	10 MM

**For custom parts, please contact us for more information.**

Additional types and sizes of fastener tools are available upon request.

# ERGO-DRIVE® SERIES

## ERGO-DRIVE® SOCKETS PROTECT...



### ...YOUR INVESTMENT!

Pulse tools are an investment and the anvil is the most expensive single part of any pulse tool. ERGO-DRIVE® sockets decrease vibration and wear on this critical component.

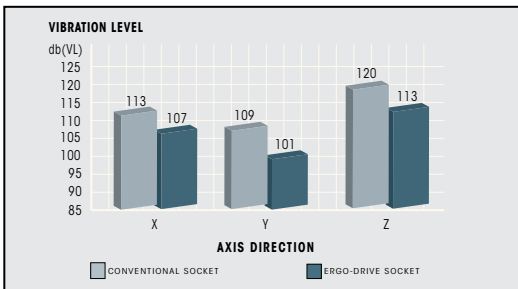

### ...YOUR ASSEMBLERS!

ERGO-DRIVE® sockets cause significantly less vibration during fastening than conventional sockets. This allows your assemblers to do their jobs without the worry of vibration related injuries.

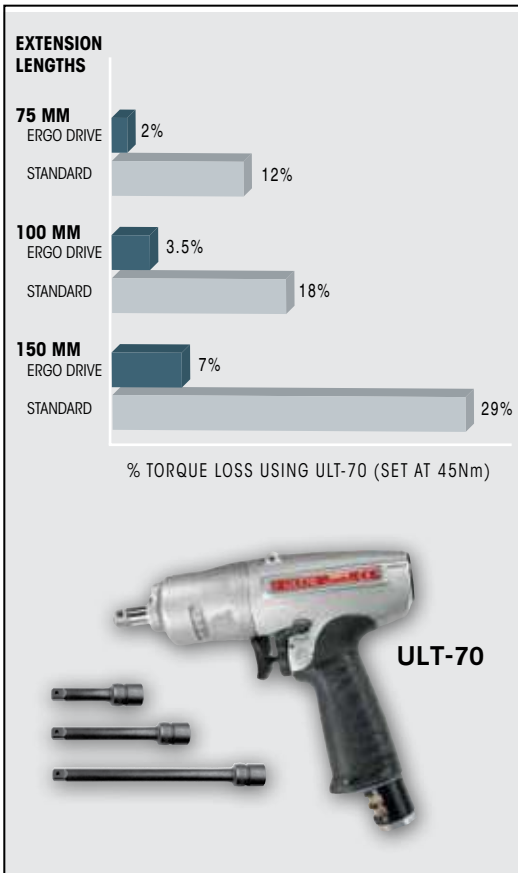

### ...YOUR PRODUCTS!

By reducing run-out and vibration, ERGO-DRIVE® sockets allow the most repeatable, accurate rundowns to take place, ensuring excellent product quality.

## ERGO-DRIVE® VS. STANDARD

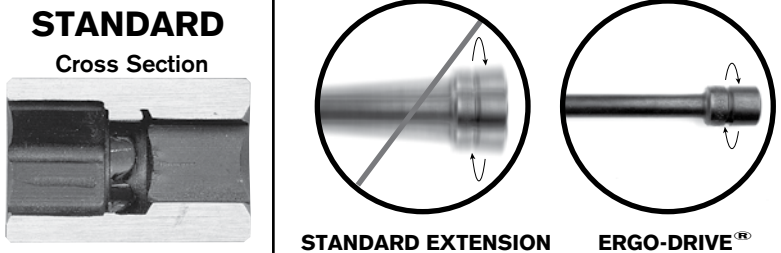

# ERGO-DRIVE® FASTENER TOOLS

## ERGO-DRIVE® SOCKETS

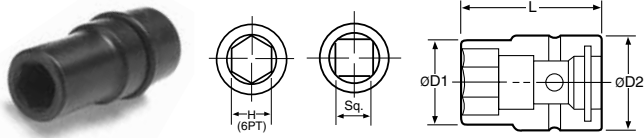

PART NO	HEX	D1	D1	D2	D2	L	L
		MM	IN	MM	IN	MM	IN

### 3/8" Square Drive

A31/4EDS	1/4"	10	0.39	19	0.75	44	1.73
A31/2EDS	1/2"	20	0.77	22	0.87	44	1.73
A306EDS	6 mm	10	0.39	19	0.75	44	1.73
A308EDS	8 mm	14	0.55	20	0.79	42	1.65
A310EDS	10 mm	17	0.65	20	0.79	42	1.65
A312EDS	12 mm	20	0.79	20	0.79	42	1.65
A314EDS	14 mm	22	0.87	20	0.79	42	1.65
A316EDS	16 mm	25	0.98	20	0.79	45	1.77
A318EDS	18 mm	27	1.06	20	0.79	45	1.77

### 1/2" Square Drive

A41/2EDS	1/2"	19	0.75	25	0.98	50	1.97
A413EDS	13 mm	22	0.85	25	0.98	52	2.05
A414EDS	14 mm	23	0.89	25	0.98	52	2.05
A415EDS	15 mm	24	0.93	25	0.98	52	2.05
A416EDS	16 mm	25	0.98	25	0.98	52	2.05
A417EDS	17 mm	28	1.10	28	1.10	54	2.13
A418EDS	18 mm	29	1.14	28	1.10	54	2.13
A419EDS	19 mm	30	1.18	28	1.10	54	2.13

### 3/4" Square Drive

A61-1/8EDS	1-1/8"	44	1.73	44	1.73	64	2.52
A61-1/4EDS	1-1/4"	49	1.91	44	1.73	66	2.60
A61-1/2EDS	1-1/2"	57	2.24	44	1.73	68	2.68
A618EDS	18 mm	31	1.22	44	1.73	60	2.36
A624EDS	24 mm	40	1.52	40	1.73	65	2.36

### 1" Square Drive

A815/16EDS	15/16"	38	1.50	54	2.13	69	2.72
A8100EDS	100 mm	136	5.35	76	2.99	120	4.72

## SEE ALSO: STUD BOLT SOCKETS

PART NO	THREAD SIZE	LENGTH MM	LENGTH IN	DRIVE IN
A31/4P20	1/4-20"	55	2.17	3/8
A305P0.8	M5	42	1.65	3/8
A41/4P20	1/4-20"	65	2.59	1/2
A406P1.0	M6	50	1.97	1/2

## ERGO-DRIVE® EXTENSIONS

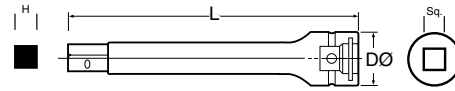

PART NO	SQ DRIVE	H	L	L	D	D
			MM	IN	MM	IN

### 3/8" Square Drive

A352EDE	3/8"	3/8"	52	2.05	20	0.79
A3100EDE	3/8"	3/8"	100	3.94	20	0.79
A375EDE	3/8"	3/8"	75	2.95	20	0.79
A3150EDE	3/8"	3/8"	150	5.91	20	0.79
A3190EDE	3/8"	3/8"	190	7.48	20	0.79
A3254EDE	3/8"	3/8"	254	10.00	20	0.79
A3300EDE	3/8"	3/8"	300	11.81	20	0.79
A3320EDE	3/8"	3/8"	320	12.60	20	0.79

### 1/2" Square Drive

A464EDE	1/2"	1/2"	64	2.52	28	1.10
A476EDE	1/2"	1/2"	76	2.99	28	1.10
A4125EDE	1/2"	1/2"	125	4.92	28	1.10
A4204EDE	1/2"	1/2"	204	8.03	28	1.10
A4254EDE	1/2"	1/2"	254	10.00	28	1.10
A4355EDE	1/2"	1/2"	355	13.98	28	1.10

### 3/4" Square Drive

A676EDE	3/4"	3/4"	76	2.99	40	1.58
A6100EDE	3/4"	3/4"	100	3.94	40	1.58
A6150EDE	3/4"	3/4"	150	5.91	40	1.58
A6200EDE	3/4"	3/4"	200	7.87	40	1.58

### 1" Square Drive

A8150EDE	1"	1"	150	5.91	54	2.13
A8200EDE	1"	1"	200	7.87	54	2.13

## QUICK CHANGE CHUCKS

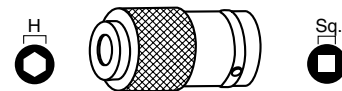

PART NO	SQUARE DRIVE	HEX
---------	--------------	-----

### 3/8" Square Drive

ADC-3SEDSQ	3/8"	1/4"
ADC-3SEDSQH7/16	3/8"	7/16"

### 1/2" Square Drive

ADC-4SEDSQ	1/2"	1/4"
ADC-4SEDSQH7/16	1/2"	7/16"

Additional types and sizes of fastener tools are available upon request.

# CUSTOM BITS, SOCKETS, AND EXTENSIONS

## CUSTOM BITS, SOCKETS, AND EXTENSIONS FOR THE POWER TOOL USER

AIMCO can provide specials for virtually any application. From design to delivery, AIMCO's quick response ensures high quality, tight tolerance specials.

### Specials are available in every style including:

- Deep Socket
- Extended Socket
- Universal
- Allen Head
- Torx Head
- Socket Adapter
- Nut Runner Socket
- Nut Runner Joint
- Nutsetter
- Magnetic Nutsetter
- Universal Nutsetter
- Screwdriver Bits



Sample request forms are shown. Your detailed requirements will allow AIMCO to quickly respond with custom solutions for your fastening requirements.

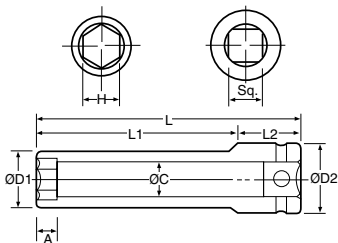

### SOCKET

Magnet MP / MT / MS	H	L	L <sub>1</sub>	L <sub>2</sub>	A	ØC	ØD <sub>1</sub>	ØD <sub>2</sub>	Sq.
SIZE									
TYPE									

# SPECIAL PARTS

## SOCKET TYPES:



DOUBLE HEX  
D (12 PT)  
(DH)



SURFACE DRIVE  
(SF)



DOUBLE SQUARE  
(DSQ)



FLANK DRIVE  
(FD)



SINGLE HEX  
H (6 PT)  
(SH)



FAST LEAD  
(FL)



SINGLE SQUARE  
(SQ)



HEX LOBULE  
(TORX)

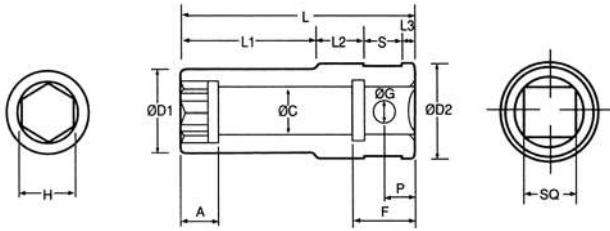

### NUTRUNNER SOCKET TYPE A

Min. Qty. 10

Magnet MP MT MS	H	L	L <sub>1</sub>	L <sub>2</sub>	L <sub>3</sub>	S	ØD <sub>1</sub>	A	ØC	ØG	P	F	ØD <sub>2</sub>	Sq.	Qty.
SIZE															
TYPE															

√ Box for Ergo-Drive

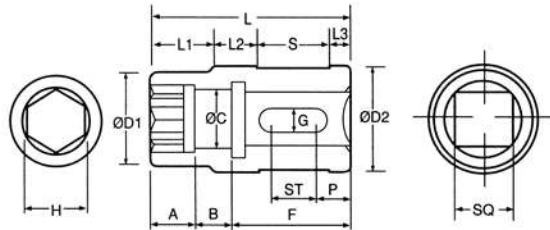

### NUTRUNNER SOCKET TYPE B

Min. Qty. 10

H	L	L <sub>1</sub>	L <sub>2</sub>	L <sub>3</sub>	L <sub>4</sub>	S	ØD <sub>1</sub>	A	B	ØC	G	P	F	ST	ØD <sub>2</sub>	Sq.	Qty.
SIZE																	
TYPE																	

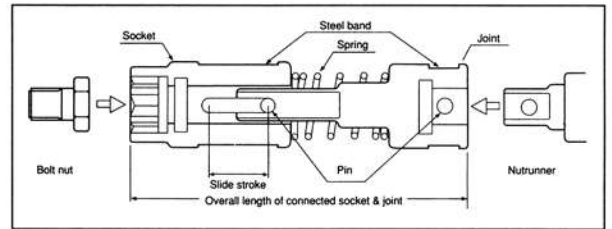
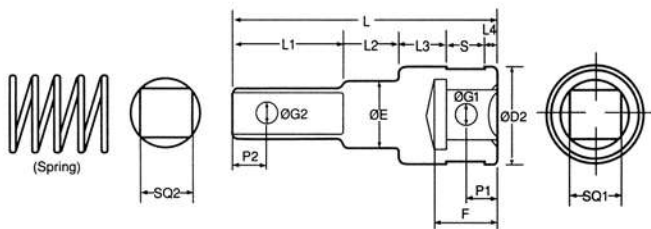

### NUTRUNNER JOINT TYPE B

Min. Qty. 10

SQ <sub>2</sub>	L	L <sub>1</sub>	L <sub>2</sub>	L <sub>3</sub>	L <sub>4</sub>	S	P <sub>1</sub>	ØG <sub>2</sub>	ØE	F	ØG <sub>1</sub>	P <sub>2</sub>	ØD <sub>2</sub>	SQ <sub>1</sub>	Qty.

√ Box for Ergo-Drive

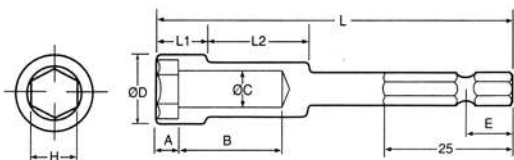

### NUT SETTER

Min. Qty. 10

H	ØD	L	E	L <sub>1</sub>	L <sub>2</sub>	A	B	ØC	Qty.
SIZE									
TYPE									

1/4(6.35)

# SPECIAL PARTS

## MAGNETIC STYLES:

MP (Press-inserted) Type

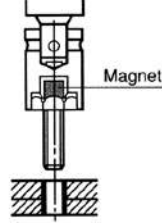

MS (Sliding) Type

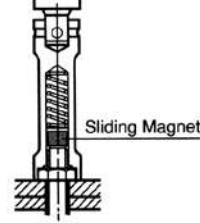

MT (Tube) Type

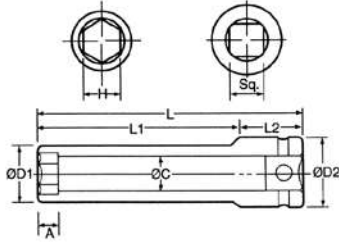
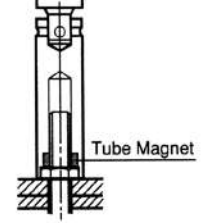

## SOCKET

Min. Qty. 10

Magnet MP MT MS	H	L	L <sub>1</sub>	L <sub>2</sub>	A	ØC	ØD <sub>1</sub>	ØD <sub>2</sub>	Sq.	Qty.
	SIZE									
TYPE										

√ Box for Ergo-Drive

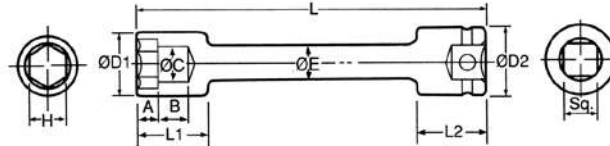

## EXTENSION SOCKET

Min. Qty. 10

Magnet MP MT MS	H	L	L <sub>1</sub>	L <sub>2</sub>	A	B	ØC	ØD <sub>1</sub>	ØD <sub>2</sub>	ØE	Sq.	Qty.
	SIZE											
TYPE												

√ Box for Ergo-Drive

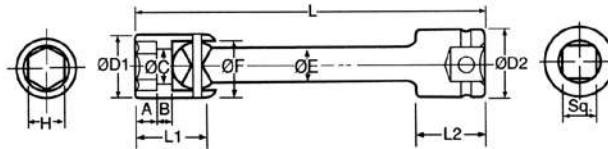

## UNIVERSAL SOCKET

Min. Qty. 10

Magnet MP MT MS	H	L	L <sub>1</sub>	L <sub>2</sub>	A	B	ØC	ØD <sub>1</sub>	ØD <sub>2</sub>	ØE	ØF	Sq.	Qty.
	SIZE												
TYPE													

√ Box for Ergo-Drive

## ALLEN HEAD/TORX HEAD

Min. Qty. 10

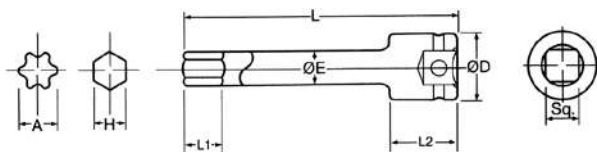

Torx	H	L	L <sub>1</sub>	L <sub>2</sub>	ØD	ØE	Sq.	Qty.

√ Box for Ergo-Drive

## SOCKET ADAPTER

Min. Qty. 10

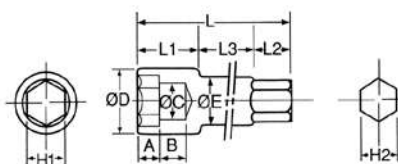

H <sub>1</sub>	L	L <sub>1</sub>	L <sub>2</sub>	L <sub>3</sub>	ØD	A	B	ØC	ØE	H <sub>2</sub>	Qty.
SIZE											
TYPE											

# SPECIAL PARTS

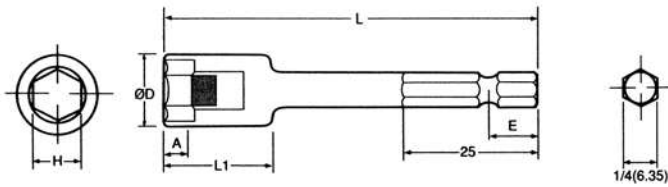

**(MP) MAGNETIC NUT SETTER**

Min. Qty. 10

	H	L	E	L <sub>1</sub>	ØD	A	Qty.
SIZE							
TYPE							

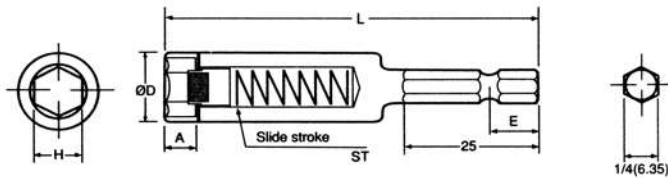

**(MS) MAGNETIC NUT SETTER**

Min. Qty. 10

	H	L	E	ØD	A	ST	Qty.
SIZE							
TYPE							

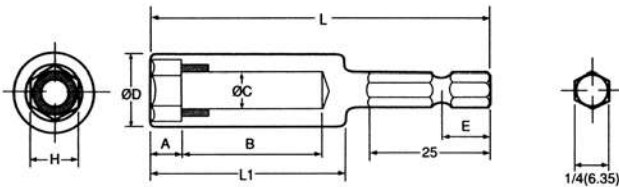

**(MT) MAGNETIC NUT SETTER**

Min. Qty. 10

	H	L	E	L <sub>1</sub>	ØD	A	B	ØC	Qty.
SIZE									
TYPE									

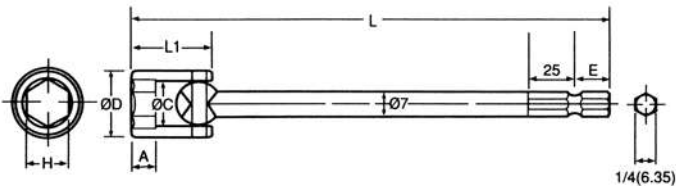

**UNIVERSAL NUT SETTER**

Min. Qty. 10

	H	L	E	L <sub>1</sub>	A	ØC	ØD	Qty.

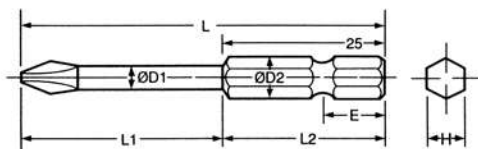

**SCREWDRIVER BIT**

Min. Qty. 500

	Point Size	L	L <sub>1</sub>	L <sub>2</sub>	ØD <sub>1</sub>	ØD <sub>2</sub>	E	H	Qty.

CIRCLE ONE:













# CONVERSION CHARTS

## Fraction ■ Decimal ■ Metric Conversions (to .32)

	Decimal	mm		Decimal	mm		Decimal	mm		Decimal	mm
1/32	.03125	.7938	9/32	.28125	7.1438	17/32	.53125	13.4938	25/32	.78125	19.8438
1/16	.0625	1.5875	5/16	.3125	7.9375	9/16	.5625	14.2875	13/16	.8125	20.6375
3/32	.09375	2.3812	11/32	.34375	8.7312	19/32	.59375	15.0812	27/32	.84375	21.4312
1/8	.125	3.175	3/8	.375	9.525	5/8	.625	15.875	7/8	.875	22.225
5/32	.15625	3.9688	13/32	.40625	10.3188	21/32	.65625	16.6688	29/32	.90625	23.0188
3/16	.1875	4.7625	7/16	.4375	11.1125	11/16	.6875	17.4625	15/16	.9375	23.8125
7/32	.21875	5.5562	15/32	.46875	11.9062	23/32	.71875	18.2562	31/32	.96875	24.6062
1/4	.25	6.35	1/2	.5	12.7	3/4	.75	19.05	1	1.0	25.4

## Thread Size to Hex Size

							
	mm		mm	UNC	Inches	SAE	Inches
M 2	4	M 27	41	1/4	7/16	1/4	7/16
M 2.3	4.5	M 30	46	5/16	1/2	5/16	1/2
M 2.6	5	M 33	50	3/8	9/16	3/8	9/16
M 3	5.5	M 36	55	7/16	11/16	7/16	5/8
M 3.5	6	M 39	60	1/2	3/4	1/2	3/4
M 4	7	M 42	65	9/16	7/8	9/16	7/8
M 5	8	M 45	70	5/8	15/16	5/8	15/16
(M 5-6)	9	M 48	75	3/4	1-1/8	3/4	1-1/16
M 6	10	M 52	80	7/8	1-5/16	7/8	1-1/4
M 7	11	M 56	85	1	1-1/2	1-1/8	1-7/16
M 8	13	M 60	90	1-1/8	1-11/16	1-1/4	1-13/16
(M 8)	14	M 64	95	1-1/4	1-7/8	1-3/8	2
M 10	16	M 68	100	1-3/8	2-1/16	1-1/2	2-3/16
(M 10)	17	M 72	105	1-1/2	2-1/4		
M 12	18	M 76	110	1-3/4	2-5/8		
(M 12)	19	M 80	115	2	3		
M 14	21	M 85	120	2-1/4	3-3/8		
(M 14)	22	M 90	130	2-1/2	3-3/4		
M 16	24	M 95	135				
M 18	27	M 100	145				
M 20	30	M 105	150				
(M 22)	32	M 110	155				
M 22	34	M 115	165				
M 24	36	M 120	170				

## Torque Conversion Factors

Units to be Converted	=	SAE			METRIC			INTERNATIONAL SYSTEM - S.I.		
		ozf-in	lbf-in	lbf-ft	gf-cm	kgf-cm	kgf-m	mNm	cNm	Nm
1 ozf-in	=	1	0.0625	0.005	72	0.072	0.0007	7.062	0.706	0.007
1 lbf-in	=	16	1	0.083	1152.1	1.152	0.0115	113	11.3	0.113
1 lbf-ft	=	192	12	1	13826	13.83	0.138	1356	135.6	1.356
1 gf-cm	=	0.014	0.0009	0.00007	1	0.001	0.00001	0.098	0.01	0.0001
1 kgf-cm	=	13.89	0.868	0.072	1000	1	0.01	98.07	9.807	0.098
1 kgf-m	=	1389	86.8	7.233	100000	100	1	9807	980.7	9.807
1 mN-m	=	0.142	0.009	0.0007	10.2	0.01	0.0001	1	0.1	0.001
1 cN-m	=	1.42	0.088	0.007	102	0.102	0.001	10	1	0.01
1 N-m	=	141.6	8.851	0.738	10197	10.20	0.102	1000	100	1

