



Abrasive Belt Tools

Dynafiler®.....	8	Dynafiler® III	18
Dynafiler® II.....	11	Dynabelter®	22
.4 hp Dynafiler® II	12	Dynangle	25
Vacuum Dynafiler® II	13	Dynangle II.....	26
Electric Dynafiler® II.....	13	“Take-About” Sander.....	27
Mini-Dynafiler® II.....	16		



Continued Leadership In Portable Abrasive Power Tool Technology

www.dynabrade.com

“The Original” Dynafile®

Air-Powered Abrasive Belt Tool

ABRASIVE CAPACITY

ABRASIVE BELTS

1/8", 1/4", 1/2" wide x 24" long
(3 mm, 6 mm, 13 mm x 610 mm)

The Best Tracking Abrasive Belt Tool in the World!

Model 14000 For 24" Long Belts

- World-famous Dynafile® replaces tedious hand filing and sanding. Grind, deburr, blend, polish, finish and more!
- Grind from contact wheel or platen pad. Finish and polish using slack of belt.
- For use on metal, plastic, fiberglass, composites, rubber, glass and stone.
- Tool includes 11218 Contact Arm for standard use. Also accepts a variety of additional Contact Arms (see page 9).
- Motor easily adjusts to the most comfortable throttle lever position.
- Superior belt tracking permits use of 1/8", 1/4" or 1/2" wide x 24" long abrasive belts.
- Work in areas as small as 3/8" diameter.
- Lightweight composite belt guard allows quick and easy belt change!
- Hard and soft platen pads mount onto contact arms for heavy grinding or contour polishing (see page 27).



Model 14000

The most recognized shape in portable abrasive belt tools!



Reach into areas as small as 3/8".



Clean and finish using non-woven nylon belts.



Arrows located on Dynafile® belt cover indicate abrasive belt direction. Grinding from the RETURN SIDE of the belt will greatly enhance tool performance and increase belt life.



Efficiently rework turbine blades with specialized contact arm.



Grind welds using belts as narrow as 1/8" wide.

Model Number	Motor hp (W)	Motor RPM	Sound Level	Abrasive Belt Size Inch (mm)	Maximum Air Flow SCFM (LPM)	Max. SFPM (SMPM)	Air Inlet Thread	Weight Pound (kg)	Length Inch (mm)	Height Inch (mm)
14000	.5 (373)	20,000	77 dB(A)	1/8-1/2 (3-13) W x 24 (610) L	31 (878)	5,800 (1,762)	1/4" NPT	3.1 (1.4)	14.6 (371)	4.6 (116)

Additional Specifications: Air Pressure 90 PSIG (6.2 Bar) • Hose I.D. Size 1/4" (6 mm)

Tune-Up Kit: No. 95600 (page 192) • Recommended Air Line Accessory: 95676 Coupler/Plug Assembly (page 161)

14010 Versatility Kit

- Includes 14000 Dynafile® with five popular Contact Arms, plus an assortment of abrasive belts, in durable case.
- Includes Contact Arms 11213, 11216, 11218, 11219 and 11231 (see page 9).
- This kit is USA Government National Stock Number 5130011263260.



Dynaswivel® air line connector is ideal for use with most air tools. The Dynaswivel® improves tool maneuverability, minimizes operator fatigue and extends hose life. (See page 163.)



Model 14010



FASTTRACK

Contact Arms: Page 9 • Abrasive Belts: Page 210 • Accessories: Page 159

Dynafile® Contact Arms

4" to 14" Workable Reach



To maximize the life of 1/4" bearings or smaller, lower the operating air pressure to 45 PSIG (3.1 Bar) and run the motor at a lower RPM.

Part Number	Comments	Belt Size (W x L)	Contact Wheel Assembly (includes bearing and shaft)	Platen Pad
11178, 11179, 11257	<ul style="list-style-type: none"> Up to 32" reach Enter slots as narrow as 3/8" Deburr 1/2" to 1" tubing  <p>11257: Custom-made. Specify length and contact wheel.</p>	11178: 1/2" x 34" (9" reach with 5/16" dia. steel contact wheel) 11179: 1/2" x 34" (9" reach with 5/8" dia. rubber contact wheel)	11178: 11068 Wheel (5/16" dia. steel) 11179: 11078 Wheel (5/8" dia. rubber)	None
11212	  <ul style="list-style-type: none"> 45 PSIG maximum File round openings as small as 7/16" 	1/4" x 24"	11066 5/16" dia. x 1/8" wide, steel	11034 1/4" wide
11213	  <ul style="list-style-type: none"> 45 PSIG maximum See 11239 for heavy-duty version 	1/2" x 24"	11068 5/16" dia. x 3/8" wide, steel	11027 1/2" wide
11214	  <ul style="list-style-type: none"> 45 PSIG maximum Work on contact wheel or platen pad 	1/2" x 24"	11070 7/16" dia. x 3/8" wide, rubber	11025 1/2" wide
11215	  <ul style="list-style-type: none"> Enter 1/2" x 1/2" openings 	1/4" x 24"	11072 7/16" dia. x 1/8" wide, brass	11034 1/4" wide
11216	  <ul style="list-style-type: none"> Enter 5/16" x 3/4" openings 	1/4" x 24"	11074 5/8" dia. x 1/8" wide, rubber	11032 1/4" wide
11217	  <ul style="list-style-type: none"> Enter channels as narrow as 9/16" 	1/2" x 24"	11076 7/16" dia. x 3/8" wide, steel	11027 1/2" wide
11218	  <ul style="list-style-type: none"> Standard arm on Model 14000 See 11228 for heavy-duty version 	1/2" x 24"	11078 5/8" dia. x 3/8" wide, rubber	11025 1/2" wide
11219	  <ul style="list-style-type: none"> No platen due to offset design Ideal for slack polishing; also grinding radiuses 	1/4" or 2" x 24"	11080 1" dia. x 3/8" wide, radiused rubber	None
11228	  <ul style="list-style-type: none"> Heavy-duty steel Optional 11028 Steel Platen available for grinding 	1/2" x 24"	11078 5/8" dia. x 3/8" wide, rubber	11025 1/2" wide
11231	  <ul style="list-style-type: none"> See 11243 for heavy-duty version 	1/2" x 24"	11084 3/4" dia. x 1/2" wide, rubber	11135 1/2" wide
11232 "V" Shaped Wheel	  <ul style="list-style-type: none"> For 1/8" wide belts No platen due to offset design Grind corners, strap polish 	1/8" or 1/4" x 24"	11086 1" dia. x 3/8" wide, tapered urethane	None

Dynafile® Contact Arms

4" to 14" Workable Reach



To maximize the life of 1/4" bearings or smaller, lower the operating air pressure to 45 PSIG (3.1 Bar) and run the motor at a lower RPM.

Part Number	Comments	Belt Size (W x L)	Contact Wheel Assembly (includes bearing and shaft)	Platen Pad
11234 	<ul style="list-style-type: none"> • Deburrs both edges of workpiece simultaneously • Contact wheels adjust for material 1/8" to 5/8" thick 	1/2" x 34"	11080 (two) 1" dia. x 3/8" wide, rubber	None
11237, 11238 Turbine Blade Arm 	<ul style="list-style-type: none"> • 45 PSIG maximum • Grind, blend and polish turbine blades • Reach areas as small as 5/16" wide • 1-1/2" strap polish area 	11237: 1/4" x 24" 11238: 1/2" x 24"	11237: 5/16" dia. x 1/8" wide, steel wheel 11238: 1/4" dia. x 3/8" wide, steel (Consists of three 11051 Bearings)	None
11239 	<ul style="list-style-type: none"> • 45 PSIG maximum • Heavy-duty steel • Grind in narrow areas 	1/2" x 24"	11068 5/16" dia. x 3/8" wide, steel	11027 1/2" wide
11240 	<ul style="list-style-type: none"> • 9" workable reach 	1/2" x 34"	11078 5/8" dia. x 3/8" wide, rubber	11025 1/2" wide
11241 	<ul style="list-style-type: none"> • 9" workable reach 	1/4" x 34"	11074 5/8" dia. x 1/8" wide, rubber	11032 1/4" wide
11243 	<ul style="list-style-type: none"> • Heavy-duty steel • Grind over contact wheel or platen pad 	1/2" x 24"	11084 3/4" dia. x 1/2" wide, rubber	11135 1/2" wide
11244, 11245 	<ul style="list-style-type: none"> • 14" workable reach 	11244: 1/2" x 44" 11245: 1/4" x 44"	11078 5/8" dia. x 3/8" wide, rubber	11025 1/2" wide
11253, 11254 Big Wheel Arm 	<ul style="list-style-type: none"> • Grinds and polishes deep slots or narrow grooves 	1/4" to 1/2" x 34"	1/4" to 1/2" wide wheels, 2-1/8" to 4-3/4" diameter (specify size)	
11255 Cross Bow Arm 	<ul style="list-style-type: none"> • I.D. polish, deburr or ream with one 180° wrist turn • Deburr leading radius of 1" to 4" round openings • Great for pipe fitters 	1/2" x 34"	11078 5/8" dia. x 3/8" wide, rubber	None
11258 Stroke Sander Arm 	<ul style="list-style-type: none"> • Blend stainless steel 	1/2" x 24"	11078 5/8" dia. x 3/8" wide, rubber 11076 7/16" dia. x 3/8" wide, steel	11025 1/2" wide
11261 "The Banana Arm" 	<ul style="list-style-type: none"> • For in-line scratch pattern 	1/2" x 24"	11078 5/8" dia. x 3/8" wide, rubber	11132 1/2" wide
11262 Offset Arm 	<ul style="list-style-type: none"> • For flat grinding using platen at or near corners and edges of large radiuses • Contact wheel is offset to prevent gouging 	1/2" x 24"	11078 5/8" dia. x 3/8" wide, rubber	11026 1/2" wide
11297 Guide-Cut Arm 	<ul style="list-style-type: none"> • Guide wheels prevent undercutting • Removes raised material within .020" or less • Use 60 to 80 grit belts 	1/2" x 24" 60 to 80 grit	11090 5/8" dia. x 3/8" wide, rubber	None

Dynafile® II

Air-Powered Abrasive Belt Tool

ABRASIVE CAPACITY
ABRASIVE BELTS
 1/4" - 3/4" wide x 18" long
 (6 mm - 19 mm x 457 mm)

Reach Normally Inaccessible Areas

- Grind, deburr, blend and polish, on metal, plastic, fiberglass, composites, rubber, glass and more. Grind from contact wheel or platen pad; finish and polish using slack of belt.
- Lightweight, ergonomic 7° offset design. Grinding head pivots 360° for securing in most efficient position.
- Belt guard easily detaches for quick abrasive change; simple belt tracking adjustment knob.



Model 40320

Model 40320 For 18" Long Belts

- Includes 11206 Contact Arm for 3/4" wide x 18" long belts (see page 14).

Model 40335 For 18" Long Belts

- Designed exclusively for use with non-woven nylon belts. Excellent for setting grain lines, achieving consistent satin finishes on metals, removing oxide and weld discoloration.
- 40375 Rubber Drive Wheel minimizes non-woven nylon belt slippage. Straight belt path extends abrasive life.
- Includes 11203 Contact Arm for 1/2" wide x 18" long medium non-woven nylon belt (90292).



Slack of abrasive belt is used to efficiently polish radiused area.

Optional 11200 Stroke Sander Arm leaves in-line scratch pattern.

Model 40381 Slow Speed, For 18" Long Belts

- 1,500 SFPM. Slow speed ensures longer belt life when working on titanium and other exotic materials.
- Includes 11206 Contact Arm for 3/4" wide x 18" long belts (see page 14).

Model 40326 For 20-1/2" Long Belts

- Includes 11287 Contact Arm for 5/8" or 3/4" wide abrasive belts. (11287 is only arm that accepts 20-1/2" long belts.)



Dynafile® II easily converts to a Die Grinder with optional 50010 Collet (1/4") or 50015 Collet (6 mm). To convert to a Drill, order 53032 Chuck (1/4").

Model Number	Motor hp (W)	Motor RPM	Sound Level	Abrasive Belt Size Inch (mm)	Maximum Air Flow SCFM (LPM)	Max. SFPM (SMPM)	Weight Pound (kg)	Length Inch (mm)	Height Inch (mm)
40320	.5 (373)	20,000	80 dB(A)	1/4-3/4 (6-19) W x 18 (457) L	28 (793)	4,550 (1,382)	2.5 (1.1)	14-1/4 (362)	4-7/8 (124)
40326	.5 (373)	20,000	80 dB(A)	1/4-3/4 (6-19) W x 20-1/2 (521) L	28 (793)	4,550 (1,382)	2.5 (1.1)	14-1/4 (362)	4-7/8 (124)
40335	.5 (373)	20,000	80 dB(A)	1/4-3/4 (6-19) W x 18 (457) L	28 (793)	4,550 (1,382)	2.5 (1.1)	14-1/4 (362)	4-7/8 (124)
40381	.4 (321)	5,000	82 dB(A)	1/4-3/4 (6-19) W x 18 (457) L	24 (680)	1,500 (457)	2.8 (1.2)	15-1/2 (394)	5-3/4 (146)

Additional Specifications: Air Inlet Thread 1/4" NPT • Hose I.D. Size 3/8" (10 mm) • Air Pressure 90 PSIG (6.2 Bar)

Tune-Up Kits: Models 40320, 40326, 40335 – No. 96044; Model 40381 – No. 96174 (page 192)

Recommended Air Line Accessory: 94300 Dynaswivel® (page 163); 95676 Coupler/Plug Assembly (page 161)

40321 Versatility Kit

- Includes 40320 Dynafile® II with 11206 Contact Arm, plus additional 11203 and 11204 Contact Arms. Also includes eight popular abrasive belts and 50010 Collet (1/4") for Die Grinder use, along with 95262 and 95281 Wrenches. All items contained in a durable carrying case.

40324 Versatility Kit Metric

- Includes 40320 Dynafile® II with 11206 Contact Arm, plus additional 11203 and 11320 Contact Arms. Also includes eight popular abrasive belts and 50015 Collet (6 mm) for Die Grinder use, along with 95262 and 95281 Wrenches. All items contained in a durable carrying case.

Model 40321



.4 hp Dynafile® II

Air-Powered Abrasive Belt Tool

NEW!

ABRASIVE
CAPACITY

ABRASIVE BELTS

1/8", 1/4", 3/4" wide x 18" long
(3 mm, 6 mm, 19 mm x
457 mm)

Lightweight, Low Profile Version of Dynafile® II

- .4 hp Dynafile® II adds a lightweight, compact variation to Dynabrade's famous Abrasive Belt Tool line. The optimal low profile belt tool for working in tight areas!
- Grind, deburr, blend, finish and polish. Grind from contact wheel or platen pad; finish and polish using slack of belt. For use on metal, plastic, fiberglass, composites, glass and more.
- Compact, low profile housing allows easy access in tight spots and previously inaccessible areas. Grinding head pivots 360° for additional flexibility. Ergonomic 7° offset handle.
- Robust .4 hp air motor serves up ample power.
- Lightweight tool design minimizes operator fatigue and increases efficiency.
- Belt guard easily detaches for quick abrasive change; simple belt tracking adjustment knob.



Model 40352 For 18" Long Belts

- Includes 11203 Contact Arm, for coated abrasive belts 1/2" wide x 18" long (see page 14).

Model 40353 For 18" Long Belts

- Designed exclusively for use with non-woven nylon belts. Excellent for setting grain lines, achieving consistent satin finishes on a variety of metals, and removing oxide and weld discoloration.
- 40375 Rubber Drive Wheel minimizes non-woven nylon belt slippage.
- Includes 11203 Contact Arm for 1/2" wide x 18" long medium non-woven nylon belt (90292).



Arrows located on Dynafile® II belt cover indicate abrasive belt direction. Grinding from the RETURN SIDE of the belt will greatly enhance tool performance and increase belt life.



.4 hp Dynafile® II is ideal for deburring and finishing in tight areas.



Optional 11204 Contact Arm offers ability to grind into contours.



Optional offset Contact Arm allows belt to conform to a variety of contours.



Clean and finish using non-woven nylon belts.



Dynaswivel® air line connector is ideal for use with most air tools. The Dynaswivel® improves tool maneuverability, minimizes operator fatigue and extends hose life. (See page 163.)



Model Number	Motor hp (W)	Motor RPM	Sound Level	Abrasive Belt Size Inch (mm)	Maximum Air Flow SCFM (LPM)	Max. SFPM (SMPPM)	Weight Pound (kg)	Length Inch (mm)	Height Inch (mm)
40352	.4 (298)	25,000	79 dB(A)	1/8 - 3/4 (3 - 19) x 18 (457)	22 (626)	5,730 (1,747)	1.9 (8.7)	14 (356)	4-1/8 (105)
40353	.4 (298)	25,000	79 dB(A)	1/8 - 3/4 (3 - 19) x 18 (457)	22 (626)	5,730 (1,747)	1.9 (8.7)	14 (356)	4-1/8 (105)

Additional Specifications: Air Inlet Thread 1/4" NPT • Hose I.D. Size 3/8" (10 mm) • Air Pressure 90 PSIG (6.2 Bar)
Tune-Up Kit: No. 96074 (page 192) • Recommended Air Line Accessory: 95676 Coupler/Plug Assembly (page 161)



FASTTRACK

Contact Arms: Page 14 • Abrasive Belts: Page 210 • Accessories: Page 159

Vacuum Dynafile® II

Air-Powered Abrasive Belt Tool

ABRASIVE CAPACITY

ABRASIVE BELTS
1/8", 1/4", 3/4" wide x 18" long
(3 mm, 6 mm, 19 mm x 457 mm)

Vacuum While You Work!

Model 40330

- Includes 11206 Contact Arm for 3/4" wide x 18" long abrasive belts.
- Excellent for grinding, deburring, finishing and polishing, on wood, plastic, fiberglass and exotic metals.
- Highly portable vacuum system works on tool's exhaust.
- Includes self-contained "bag-within-bag" dust collection system. 54288 "bag-within-bag" system also sold separately.
- Air line is included and joined to exhaust hose to form "one cord" for superb maneuverability.



Model Number	Motor hp (W)	Motor RPM	Sound Level	Abrasive Belt Size Inch (mm)	Maximum Air Flow SCFM (LPM)	Max. SFPM (SMPM)	Weight Pound (kg)	Length Inch (mm)	Height Inch (mm)
40330	.5 (373)	20,000	93 dB(A)	1/4-3/4 (6-19) W x 18-24 (457-610) L	28 (793)	4,550 (1,382)	2.5 (1.1)	14-1/4 (362)	5 (127)

Additional Specifications: Air Inlet Thread 1/4" NPT • Hose I.D. Size 3/8" (10 mm) • Air Pressure 90 PSIG (6.2 Bar)
Tune-Up Kit: No. 96044 (page 192)

Electric Dynafile® II

Electric-Powered Abrasive Belt Tool

ABRASIVE CAPACITY

ABRASIVE BELTS
1/8", 1/4", 3/4" wide x 18" long
(3 mm, 6 mm, 19 mm x 457 mm)

Electric Version of World-Famous Abrasive Belt Tool

Model 40590 120 V (AC)

- Electric Dynafile® II runs coated abrasive and non-woven nylon belts, and is ideal for grinding, deburring, blending, finishing and surface conditioning.
- Tool includes 11203 contact arm, for abrasive belts 1/2" wide x 18" long.
- Also accepts over 20 interchangeable contact arms, for use with belts 1/4" to 3/4" wide x 18" long (see page 14).
- Side handle included for operator comfort. Handle is reversible for left or right hand use.
- Tool is double-insulated for safety, and includes electric cord 8 feet in length.



40591 Versatility Kit

- Includes 40590 Electric Dynafile® II with 11203 Contact Arm and two additional arms (11202 and 11204). Also includes eight abrasive belts of various grits, and an assortment of platen pads. All items contained in durable carrying case.



Model Number	Motor RPM	Maximum Watts Out	Abrasive Belt Size Inch (mm)	Voltage	Current Amps	Phase	Frequency	Maximum SFPM (SMPM)	Weight Pound (kg)	Length Inch (mm)	Height Inch (mm)
40590	11,600	600	1/4-3/4 (6-19) W x 18-24 (457-610) L	120 V (AC)	6.7	1	60 Hz	2,500 (762)	4.6 (2.1)	17-1/2 (445)	4-3/4 (121)











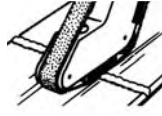



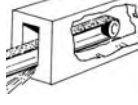



Dynafile® II Contact Arms

For Air and Electric Models - 4" to 17" Workable Reach

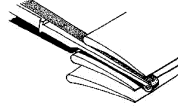

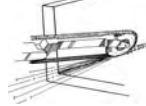
Optional 40078 Adapter allows use of 24" long belts. Extends reach to 7" when used with standard contact arms

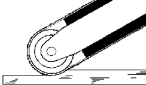
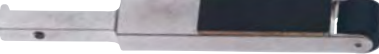
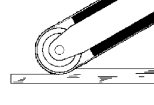











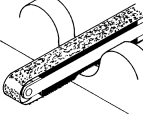

Part Number	Comments	Belt Size (W x L)	Contact Wheel Assembly (includes bearing and shaft)	Platen Pad
11200	  <ul style="list-style-type: none"> Work on broad areas Leave in-line scratch Blend spot welds 	1/2" x 18"	11088 5/8" dia. x 3/8" wide, rubber	11025 1/2" wide
11201	  <ul style="list-style-type: none"> 45 PSIG maximum Enter channels as small as 7/16" 	1/2" x 18"	11068 5/16" dia. x 3/8" wide, steel	11027 1/2" wide
11202	  <ul style="list-style-type: none"> Enter 5/16" x 3/4" openings 	1/4" x 18"	11074 5/8" dia. x 1/8" wide, rubber	11032 1/4" wide
11203	<p>Order 11312 for heavy-duty version.</p>   <ul style="list-style-type: none"> Standard on models 40335 and 40590 Grind over contact wheel or platen 	1/2" x 18"	11078 5/8" dia. x 3/8" wide, rubber	11025 1/2" wide
11204	  <ul style="list-style-type: none"> Unique offset design Strap polishing is easy with this arm 	1/8", 1/4" or 1/2" x 18"	11080 1" dia. x 3/8" wide, radiused rubber	None
11206	<p>Order 11326 for heavy-duty version.</p>   <ul style="list-style-type: none"> Standard on models 40320 and 40330 	5/8" or 3/4" x 18"	11282 3/4" dia. x 5/8" wide, rubber	11109 3/4" wide
11220, 11300, 11301, 11341	  <ul style="list-style-type: none"> 45 PSIG maximum Offset design and miniature contact wheels 2" strap polish in offset area; polish turbine blades and other contours 	11220: 5/8" or 3/4" x 18" All Others: 1/2" x 18"	11220: 11352 5/16" dia. x 5/8" wide, steel 11300: 11332 1/4" dia. x 3/8" wide, steel 11301: 11068 5/16" dia. x 3/8" wide, steel 11341: 11342 5/16" dia. x 3/8" wide, rubber	None None None None
11280	  <ul style="list-style-type: none"> Grind corners, enter grooves, strap polish "V" shape wheel 	1/8" or 1/4" x 18"	11086 1" dia. x 3/8" wide, urethane, tapered	None
11286	  <ul style="list-style-type: none"> 11024 Steel Platen available 6-3/4" workable reach 	1/2" x 24"	11078 5/8" dia. x 3/8" wide, rubber	11025 1/2" wide
11287	  <ul style="list-style-type: none"> Standard on Model 40326 Grind on wheel or platen 5-1/4" reach 	5/8" or 3/4" x 20-1/2"	11282 3/4" x 5/8" wide, rubber	11109 3/4" wide

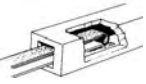
Dynafile® II Contact Arms

For Air and Electric Models - 4" to 17" Workable Reach



Optional 40078 Adapter allows use of 24" long belts. Extends reach to 7" when used with standard contact arms

Part Number	Comments	Belt Size (W x L)	Contact Wheel Assembly (includes bearing and shaft)	Platen Pad
11304 "The Banana Arm" 	<ul style="list-style-type: none"> Work on broad areas; levels in-line scratch; blend stainless 	1/2" x 18"	11078 5/8" dia. x 3/8" wide, rubber	11132 1/2" wide
11312  	<ul style="list-style-type: none"> Heavy-duty steel Grind over contact wheel or platen 	1/2" x 18"	11078 5/8" dia. x 3/8" wide, rubber	11025 1/2" wide
11314  	<ul style="list-style-type: none"> 45 PSIG maximum File round openings as small as 7/16" 	1/4" x 18"	11066 5/16" dia. x 1/8" wide, steel	11034 1/4" wide
11320 Offset Arm  	<ul style="list-style-type: none"> For flat grinding using platen at or near corners and edges of large radius round Contact wheel is offset to prevent gouging 	1/2" x 18"	5/8" dia. x 3/8" wide, rubber	11026 1/2" wide
11321  	<ul style="list-style-type: none"> 45 PSIG maximum Work on contact wheel or platen pad 	1/2" x 18"	11070 7/16" dia. x 3/8" wide, rubber	11025 1/2" wide
11322 	<ul style="list-style-type: none"> Guide-cut Removes raised material within .020" or less without undercutting 	1/2" x 18" 60 to 80 grit	11090 5/8" dia. x 3/8" wide, rubber	None
11329 	<ul style="list-style-type: none"> Extra length arm 17" workable reach 	1/2" x 44"	11078 5/8" dia. x 3/8" wide, rubber	11025 1/2" wide
11330  	<ul style="list-style-type: none"> Enter 1/2" x 1/2" openings 	1/4" x 18"	11072 7/16" dia. x 1/8" wide, brass	11034 1/4" wide
11337  	<ul style="list-style-type: none"> Enter channels as narrow as 9/16" 	1/2" x 18"	11076 7/16" dia. x 3/8" wide, steel	11027 1/2" wide
11350 	<ul style="list-style-type: none"> 45 PSIG maximum Excellent for cleaning oxide off electrical bus bars Arm has a 12" workable reach 	3/4" x 34"	11352 5/16" dia. x 5/8" wide, steel	Optional 3/4" wide
11360 	<ul style="list-style-type: none"> Unique offset design Grind over contact wheels or strap polish 	1/2" x 18"	11078 5/8" dia. x 3/8" wide, rubber	None

Mini-Dynafile® II

Air-Powered Abrasive Belt Tool

ABRASIVE CAPACITY

ABRASIVE BELTS
1/8", 1/4", 1/2" wide x 12" long
(3 mm, 6 mm, 13 mm
x 305 mm)

Ideal for Strap Polishing and Working in Narrow Openings

Model 15003 For 12" Long Belts

- Tool includes 15026 Contact Arm for 1/2" wide x 12" long abrasive belts and 15118 Drive Wheel. (See page 17 for additional Contact Arms.)
- Lightweight ergonomic design handle features 7° offset. Multi-position grinding head pivots 360°.
- Belt guard easily detaches for quick abrasive change; simple belt tracking adjustment knob.



- For added versatility, tool can be easily converted to Die Grinder with optional 01644 (1/4") Threaded Collet Insert.



- 40378 Rubber Drive Wheel may be ordered separately, for efficient use with optional non-woven nylon belts.



Effective for blending stainless steel and grinding right angle welds.

Ideal for finishing and deburring within narrow openings.



Clean and finish using non-woven nylon belts.



Finish rough-cut edges quickly and efficiently.

Model Number	Motor hp (W)	Motor RPM	Sound Level	Abrasive Belt Size Inch (mm)	Maximum Air Flow SCFM (LPM)	Max. SFPM (SMPM)	Weight Pound (kg)	Length Inch (mm)	Height Inch (mm)
15003	.4 (298)	25,000	80 dB(A)	1/8-1/2 (3-13) W x 12 (305) L	20 (566)	4,890 (1,486)	1.8 (.8)	11-3/4 (298)	3-1/2 (89)

Additional Specifications: Air Inlet Thread 1/4" NPT • Hose I.D. Size 1/4" (6 mm) • Air Pressure 90 PSIG (6.2 Bar)
Tune-Up Kit: No. 96074 (page 192) • Recommended Air Line Accessory: 95676 Coupler/Plug Assembly (page 161)

15006 Versatility Kit

- 15003 Tool (15118 Drive Wheel) with 15026 Contact Arm for 1/2" wide x 12" long abrasive belts. Also includes 15028 and 15030 Arms. (See page 17 for all Contact Arms.)
- Includes 01644 Threaded Collet Insert to easily convert tool to 1/4" Die Grinder.
- Assorted coated and non-woven nylon belts; durable carrying case.



Optional 94994 Overhose Assembly (see page 157) reduces sound levels by as much as 5 dB(A). Overhose also directs exhaust away from operator and work piece. Air line sold separately.



FASTTRACK

Contact Arms: Page 17 • Abrasive Belts: Page 209 • Accessories: Page 159

Mini-Dynafile® II Contact Arms

3" Workable Reach; Exclusive to the Mini-Dynafile® II

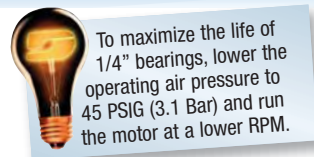

Part Number	Comments	Belt Size (W x L)	Contact Wheel Assembly (includes bearing and shaft)	Platen Pad
<p>15026</p>	<ul style="list-style-type: none"> Standard on Model 15003 Grind corners, enter grooves 	1/2" x 12"	11078 5/8" dia. x 3/8" wide, rubber	11026 1/2" wide
<p>15027</p>	<ul style="list-style-type: none"> Sand on both sides of arm Enter confined areas as small as 1/4" 	1/4" x 12"	11074 5/8" dia. x 1/8" wide, rubber	11033 1/4" wide
<p>15028</p>	<ul style="list-style-type: none"> No platen due to offset design Grind radiuses Offset for slack polishing 	1/4" or 1/2" x 12"	11080 1" dia. x 3/8" wide, rubber	None
<p>15029</p>	<ul style="list-style-type: none"> Grind corners, enter grooves and strap polish 	1/8" x 12"	11086 1" dia. x 3/8" wide, urethane	None
<p>15030</p>	<ul style="list-style-type: none"> 45 PSIG maximum Enter channels as narrow as 7/16" 	1/2" x 12"	11068 5/16" dia. x 3/8" wide, steel	11027 1/2" wide
<p>15031</p>	<ul style="list-style-type: none"> 45 PSIG maximum Work on contact wheel or platen pad 	1/2" x 13"	11070 7/16" dia. x 3/8" wide, rubber	11027 1/2" wide
<p>15032</p>	<ul style="list-style-type: none"> 45 PSIG maximum Grind, blend and polish turbine blades 	1/2" x 12"	11332 1/4" dia. x 3/8" wide, steel	None
<p>15033</p>	<ul style="list-style-type: none"> 45 PSIG maximum Grind, polish turbine blades and other contours 	1/4" x 12"	11342 5/16" dia. x 3/8" wide, rubber	None

Dynafile® III

Air-Powered Abrasive Belt Tool

ABRASIVE CAPACITY
ABRASIVE BELTS
 1/4", 1/2", 3/4", 1" wide x
 18" long (6 mm, 13 mm,
 19 mm, 25 mm x 457 mm)

Excellent for Grinding Welds, Blending and Deburring

Model 15300 For 18" Long Belts

- Dynafile® III Abrasive Belt Tool offers all the versatility of our world-famous Dynafile® II, while serving up more power (.7 hp / 522 W) for faster material removal.
- Tool includes high-efficiency Rubber Drive Wheel, ideal for use with all abrasive belts.
- Includes 15350 Contact Arm for 1" wide x 18" long belts (see page 20).
- Tool grinding head pivots 360°.
- Soft grip handle assembly allows operator to apply additional force to contact wheel. Handle also offers enhanced control and maneuverability.
- Optional safety-lock throttle lever is available.



Below: Strap sanding with optional 15375 Arm



Several Dynafile® III Contact Arms serve a dual purpose. These Arms are REVERSIBLE to allow for platen sanding OR strap polishing. (See page 20.)



Dynafile® II Contact Arms may also be used with Dynafile® III. (See page 14.)



Utilized for blending scratch patterns and grinding right angle welds.



15350 Contact Arm with serrated wheel allows aggressive removal.

Model Number	Motor hp (W)	Motor RPM	Sound Level	Abrasive Belt Size Inch (mm)	Maximum Air Flow SCFM (LPM)	Max. SFPM (SMPM)	Weight Pound (kg)	Length Inch (mm)	Height Inch (mm)
15300	.7 (522)	20,000	87 dB(A)	1/4 - 1 (6-25) W x 18 (457) L	32 (906)	4,550 (1,382)	2.5 (1.1)	14-1/4 (362)	4-7/8 (124)

Additional Specifications: Air Inlet Thread 1/4" NPT • Hose I.D. Size 3/8" (10 mm) • Air Pressure 90 PSIG (6.2 Bar)
 Tune-Up Kit: No. 96233 (page 192) • Recommended Air Line Accessory: 95676 Coupler/Plug Assembly (page 161)

15302 Versatility Kit

- Includes 15300 Dynafile® III with 15321, 15350 and 15357 Contact Arms (see page 20), plus assortment of abrasive belts, spare 15336 Drive Wheel, wrenches and hex keys, all in durable carrying case.



Dynaswivel® air line connector is ideal for use with most air tools. The Dynaswivel® improves tool maneuverability, minimizes operator fatigue and extends hose life. (See page 163.)



Model 15302

Dynafile® III

Air-Powered Abrasive Belt Tool

ABRASIVE CAPACITY
ABRASIVE BELTS
 1/4", 1/2", 3/4", 1" wide x
 18" long (6 mm, 13 mm,
 19 mm, 25 mm x 457 mm)

Lightweight Models With Popular Contact Arms

- Dynafile® III Abrasive Belt Tool offers all the versatility of our world-famous Dynafile® II, while serving up more power (.7 hp / 522 W) for faster material removal.
- Responding to the needs of the marketplace, Dynabrade now offers additional Dynafile® III models. These tools are equipped with our most popular Contact Arms, ideal for a variety of applications.
- Models do not include side handle, reducing tool weight and allowing greater maneuverability. (53163 side handle is still available as an option.)
- Models include high-efficiency Rubber Drive Wheel, ideal for use with all abrasive belts.
- Tool grinding head pivots 180°.



Model 15400

Model 15400 For 18" Long Belts

- Includes 11206 Contact Arm for belts 5/8" or 3/4" wide x 18" long (see page 20).

Model 15401 For 20-1/2" Long Belts

- Includes 11287 Contact Arm for belts 5/8" or 3/4" wide x 20-1/2" long (see page 20).



15400 Dynafile® III allows finishing and deburring in restricted areas.



15420 tool (below) includes unique 11702 Contact Arm with hand guide.

Model Number	Motor hp (W)	Motor RPM	Sound Level	Abrasive Belt Size Inch (mm)	Maximum Air Flow SCFM (LPM)	Max. SFPM (SMPM)	Weight Pound (kg)	Length Inch (mm)	Height Inch (mm)
15400	.7 (522)	20,000	87 dB(A)	5/8 (16) or 3/4 (19) W x 18 (457) L	32 (906)	4,550 (1,382)	2.5 (1.1)	14-1/4 (362)	4-7/8 (124)
15401	.7 (522)	20,000	87 dB(A)	5/8 (16) or 3/4 (19) W x 20-1/2 (521) L	32 (906)	4,550 (1,382)	2.5 (1.1)	15-1/2 (394)	4-7/8 (124)

Additional Specifications: Air Inlet Thread 1/4" NPT • Hose I.D. Size 3/8" (10 mm) • Air Pressure 90 PSIG (6.2 Bar)
 Tune-Up Kit: No. 96233 (page 192) • Recommended Air Line Accessory: 95676 Coupler/Plug Assembly (page 161)

Model 15420 For 24" Long Belts

- Includes 11702 Contact Arm with unique 4" diameter wheel (see page 20), for grinding or blending right angle welds and fillit welds. Contact Arm includes hand guide for additional control. Saves time and reduces costs!
- Grinds corner welds with no undercutting.
- Tool accepts belts 24" long, in widths of 1/4" or 1/2".

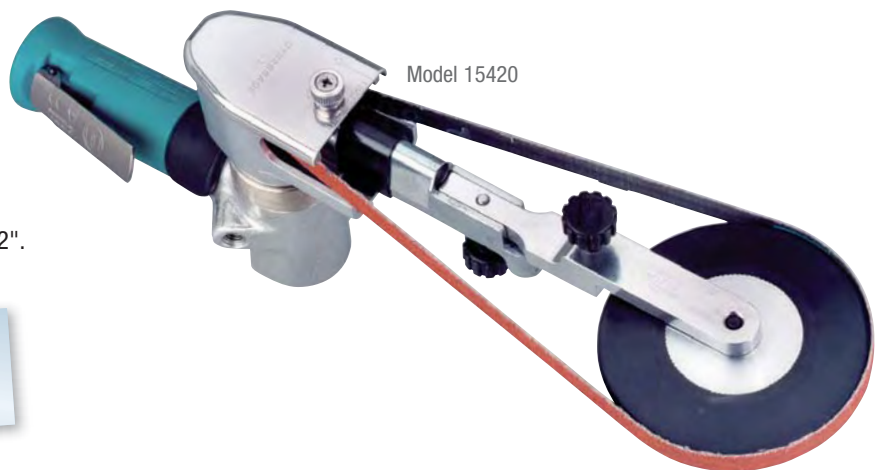

Model 15420



Arrows located on Dynafile® belt cover indicate abrasive belt direction. Grinding from the RETURN SIDE of the belt will greatly enhance tool performance and increase belt life.

Model Number	Motor hp (W)	Motor RPM	Sound Level	Abrasive Belt Size Inch (mm)	Maximum Air Flow SCFM (LPM)	Max. SFPM (SMPM)	Weight Pound (kg)	Length Inch (mm)	Height Inch (mm)
15420	.7 (522)	20,000	87 dB(A)	1/4 (6) or 1/2 (13) W x 24 (610) L	32 (906)	4,550 (1,382)	2.5 (1.1)	14 (356)	4-7/8 (124)

Additional Specifications: Air Inlet Thread 1/4" NPT • Hose I.D. Size 3/8" (10 mm) • Air Pressure 90 PSIG (6.2 Bar)
 Tune-Up Kit: No. 96233 (page 192) • Recommended Air Line Accessory: 95676 Coupler/Plug Assembly (page 161)



Dynafile® III Contact Arms

4" to 6-3/4" Workable Reach

Part Number	Comments	Belt Size (W x L)	Contact Wheel Assembly (includes bearing and shaft)	Platen Pad
11200	 <ul style="list-style-type: none"> • Work on broad areas • Leave in-line scratch • Blend stainless 	1/2" x 18"	11088 5/8" dia. x 3/8" wide, rubber	11025 1/2" wide
11203	 <ul style="list-style-type: none"> • Standard on Models 40335 and 40590 • Grind over contact wheel or platen • Order 11312 for heavy-duty, or 11325 for steel platen version 	1/2" x 18"	11078 5/8" dia. x 3/8" wide, rubber	11025 1/2" wide
11204	 <ul style="list-style-type: none"> • Unique offset design • Strap polishing is easy with this arm 	1/8", 1/4" or 1/2" x 18"	11080 1" dia. x 3/8" wide, radiused rubber	None
11206	 <ul style="list-style-type: none"> • Standard on Models 40320 and 40330 • Order 11326 for heavy-duty steel construction version 	5/8" or 3/4" x 18"	11282 3/4" dia. x 5/8" wide, rubber	11109 3/4" wide
11286	 <ul style="list-style-type: none"> • 11024 Steel Platen available • 6-3/4" workable reach 	1/2" x 24"	11078 5/8" dia. x 3/8" wide, rubber	11025 1/2" wide
11287	 <ul style="list-style-type: none"> • Standard on Model 40326 • Grind on wheel or platen • 5-1/4" reach 	5/8" or 3/4" x 20-1/2"	11282 3/4" dia. x 5/8" wide, rubber	11109 3/4" wide
11320 Offset Arm	 <ul style="list-style-type: none"> • For flat grinding using platen at or near corners and edges of large radius round • Contact wheel is offset to prevent gouging bus bars 	1/2" x 18"	11078 5/8" dia. x 3/8" wide, rubber	11026 1/2" wide
11702	 <ul style="list-style-type: none"> • Perfectly designed to reach up to 2" in a channel • Great for use with scalloped edge abrasives, blending weld seams 	1/2" or 1" x 30"	11638 70 durometer 4" dia. x 1/2" wide, radiused rubber	None

Dynafile® III Contact Arms

4" to 6-3/4" Workable Reach

Part Number	Comments	Belt Size (W x L)	Contact Wheel Assembly (includes bearing and shaft)	Platen Pad
<p>15321</p> 	<ul style="list-style-type: none"> For flat grinding using platen pad 	1" x 18"	15320 3/4" dia. x 7/8" wide, rubber	15323 1" wide
<p>15326</p> 	<ul style="list-style-type: none"> Allows for longer reach Grind using platen pad 	1" x 24"	15320 3/4" dia. x 7/8" wide, rubber	15323 1" wide
<p>15350</p> 	<ul style="list-style-type: none"> Reversible arm - arm can be flipped to allow for platen sanding or strap polishing Standard with tool 	1" x 18"	15349 90 durometer 2" dia. x 1" wide, rubber	15323 1" wide
<p>15351</p> 	<ul style="list-style-type: none"> Reversible arm - arm can be flipped to allow for platen sanding or strap polishing 	1" x 18"	15348 70 durometer 2" dia. x 1" wide, rubber	15323 1" wide
<p>15356</p> 	<ul style="list-style-type: none"> Reversible arm - arm can be flipped to allow for platen sanding or strap polishing 	1" x 18"	15346 40 durometer 2" dia. x 5/8" wide, rubber	15323 1" wide
<p>15357</p> 	<ul style="list-style-type: none"> Reversible arm - arm can be flipped to allow for platen sanding or strap polishing "V" shape wheel 	1" x 18"	15347 2" dia. x 1" wide, rubber	15323 1" wide
<p>15368</p> 	<ul style="list-style-type: none"> Allows for longer reach Grind using wheel surface 	1" x 30"	15359 70 durometer 1" dia. x 1" wide, serrated rubber	None
<p>15375</p> 	<ul style="list-style-type: none"> Great for strap polishing 	1" x 24"	15348 70 durometer 2" dia. x 1" wide, rubber	None

Dynabelter®

Air-Powered Abrasive Belt Tool

ABRASIVE CAPACITY

ABRASIVE BELTS

1", 2" wide x 30" long
(25 mm, 51 mm x 762 mm)

For Weld Grinding, Blending and Finishing on Metal and Other Surfaces

- Dynabelter® is ideal for work on ferrous and non-ferrous metals, wood, plastic, stone and composites.
- Uses include grinding cylinders, deburring castings, cleaning welds and fabricating metals.
- Also excellent for polishing tubing, deburring structural steel, finish-dimensioning on lathe work and blending inside corners.
- Safety-lock lever throttle included on all models.



After attaching new abrasive belt, hold tool by the contact wheel and suspend tool vertically, to ensure that the belt is taut. Then tighten knob and flip tension lever.



Model 11475 is ideal for grinding circumferential welds.



Model 11476 grinds weld seam and leaves in-line scratch pattern.

Model 11475 Standard Duty, .7 hp

- Accepts 1" wide x 30" long abrasive belts.
- Adjustable speed; removable side handle.
- Includes 11681 Contact Arm Assembly (see page 24).
- Ideal for use with 1/4" Dynaswivel® (see page 163), and 95676 Coupler/Plug Assembly (see page 161).



Model 11475

Model 11476 Heavy-Duty, 1.2 hp

- Accepts 1" wide x 30" long abrasive belts.
- Includes 11681 Contact Arm Assembly (see page 24), and top control handle.
- Ideal for use with 3/8" Dynaswivel® (see page 163), and 98265 Coupler/Plug Assembly (see page 161).



Placing Dynabelter® motor at a 45° angle from the belt housing will increase pressure while grinding. Pull tool towards you, working off the RETURN SIDE of the belt for faster removal.

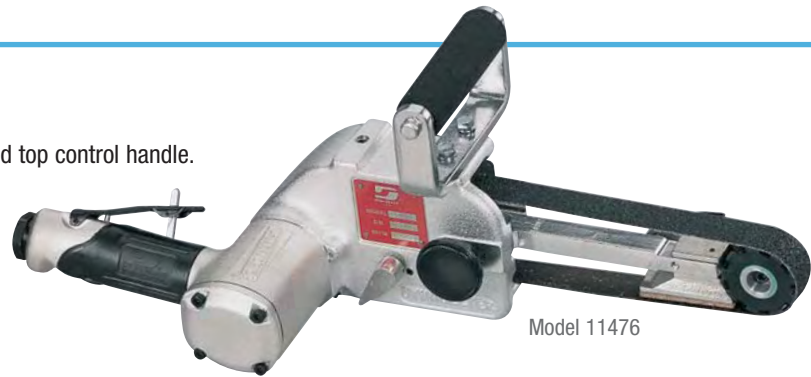

Model 11476

Model 11477 Extra Heavy-Duty, 2.0 hp

- Accepts 2" wide x 30" long abrasive belts.
- Includes pressure bar with top control handle.
- Includes 11870 Contact Arm Assembly (see page 24).
- 11871 Contact Arm with 4" dia. contact wheel is available for 2" wide x 60" long belts, providing a 20" workable reach. Optional 11891 Platen is available for 11871 Arm (see page 24).
- Ideal for use with 1/2" Dynaswivel® (see page 163), and 98273 Coupler/Plug Assembly (see page 161).

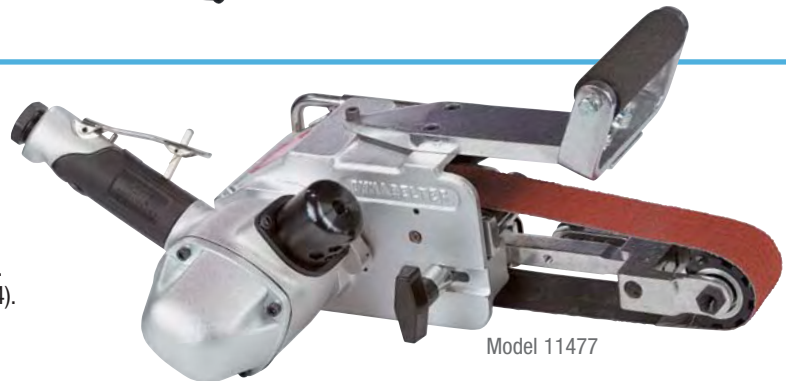

Model 11477

Model Number	Motor hp (W)	Motor RPM	Sound Level	Abrasive Belt Size Inch (mm)	Air Inlet Thread	Maximum Air Flow SCFM (LPM)	Max. SFPM (SMPM)	Weight Pound (kg)	Length Inch (mm)	Height Inch (mm)
11475	0.7 (522)	18,000	92 dB(A)	1/4-1 (6-25) W x 30 (762) L	1/4" NPT	32 (906)	5,890 (1,789)	7.5 (3.4)	21 (533)	7-1/4 (184)
11476	1.2 (895)	13,000	89 dB(A)	1/4-1 (6-25) W x 30 (762) L	3/8" NPT	58 (1,643)	4,250 (1,295)	10 (4.5)	21 (533)	7-1/4 (184)
11477	2.0 (1,492)	7,200	82 dB(A)	1-2 (25-51) W x 30 (762) L	1/2" NPT	70 (1,982)	4,700 (1,432)	14 (6.4)	21-1/2 (546)	7-3/4 (197)

Additional Specifications: Hose I.D. Size 1/2" (13 mm) • Air Pressure 90 PSIG (6.2 Bar)

Tune-Up Kits: Model 11475 – No. 96045; Model 11476 – No. 96011; Model 11477 – No. 96259 (page 192)



Dynabelter® Accu-Grinder

Air-Powered Abrasive Belt Tool with Adjust-A-Wheel

ABRASIVE CAPACITY
ABRASIVE BELTS
 1" wide x 30" long
 (25 mm x 762 mm)

Grinds Welds Flat, Without Undercutting

Model 11486 Heavy-Duty, 1.2 hp

- Efficiently removes excess weld material and leaves a narrow "in-line" scratch pattern. This model takes the guesswork out of weld grinding, and prevents undercutting!

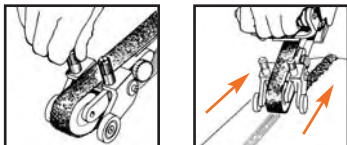

- Adjustable guide tires control the depth of abrasive belt cut. Simple twist-knobs adjust depth of cut. Allows controlled grinding on flats, contours and inside/outside of pipes and tanks.
- Includes 11717 Adjust-A-Wheel Contact Arm with 90-durometer standard serrated Contact Wheel, 2" diameter x 1" wide (see page 24).

Work on Longitudinal Welds:

- I.D. – 12" diameter pipe or larger.
- O.D. – 8" diameter pipe or larger.



Model 11486

Place 11486 Dynabelter handle at 45° angle from belt housing to increase grinding pressure. Pull tool toward operator for faster material removal.

Model Number	Motor hp (W)	Motor RPM	Sound Level	Abrasive Belt Size Inch (mm)	Maximum Air Flow SCFM (LPM)	Max. SFPM (SMPM)	Air Inlet Thread	Weight Pound (kg)	Length Inch (mm)	Height Inch (mm)
11486	1.2 (895)	13,000	89 dB(A)	1 (25) W x 30 (762) L	58 (1,643)	4,220 (1,282)	3/8" NPT	9.0 (4.1)	22 (559)	7 (178)

Additional Specifications: Hose I.D. Size 1/2" (13 mm) • Air Pressure 90 PSIG (6.2 Bar)

Tune-Up Kit: No. 96011 (page 192) • Recommended Air Line Accessory: 98265 Coupler/Plug Assembly (page 161)

Dynabelter® Accessories

11739 Dynabelter® Adapter

- Dynaflex® Contact Arms (see pg. 9), can be mounted on 11475 and 11476 Dynabelter® models with optional 11739 Adapter.
- Allows for work in small areas using 30" belts (8" reach).



Model 11739

Dynabelter® Contact Arm Extender

- Allows for longer abrasive belts! The Dynabelter® uses standard 30" long abrasive belts, however, these extenders allow Contact Arms to use longer abrasive belts.
- Extenders can only be used with Dynabelter® Contact Arms.

11656 Extender

- For 42" belts (13" reach)

11657 Extender

- For 54" belts (19" reach)

11679 Extender

- For 60" belts (21" reach)









Model 11656

Model 11679



Dynabelter® Contact Arms

Variety of Contact Wheels and Wheel Assemblies

Part Number	Comments	Belt Size (W x L)	Contact Wheel Assembly (includes bearing and shaft)	Platen Pad
11681	 <ul style="list-style-type: none"> 7-1/2" workable reach Grind using platen pad 	1" x 30"	11650 (Included) 70 durometer standard serrated serrated rubber, 2" dia. x 1" wide 11618 90 durometer standard serrated rubber, 2" dia. x 1" wide	11605 1" x 2-1/2"
11663	 <ul style="list-style-type: none"> Grind, deburr, polish over platen 7-1/2" workable reach 	1" x 30"	11616 80 durometer smooth rubber, 1" dia. x 1" wide	11605 1" x 2-1/2"
11668	 <ul style="list-style-type: none"> Wheel mount pivots to maintain surface contact Work on broad areas, blend stainless Leaves "in-line" scratch pattern 6" workable reach 	1" x 30"	11616 Two wheels, 80 durometer smooth rubber, 1" dia. x 1" wide	11605 1" x 1-7/8"
11677	 <ul style="list-style-type: none"> Grind, blend, polish welds Strap polish using slack of belt 7" workable reach 	1" x 30"	11620 40 durometer smooth rubber, (80 durometer available, 11622) 4" dia. x 1"	None
11682	 <ul style="list-style-type: none"> Grind, deburr fillet welds, inside corners 7" workable reach 	1/2" or 1" wide x 30" long	11638 70 durometer radiused rubber, 4" dia. x 1/2" wide	None
11684	 <ul style="list-style-type: none"> Polish contours without gouging workpiece Ideal for stainless pipe 7" workable reach 	1" x 30"	11642 40 durometer serrated rubber, (80 durometer wheel – 11892; 90 durometer wheel – 11888) 4" dia. x 5/8" wide	None
11717	 <ul style="list-style-type: none"> For best results when ordering 11717 Contact Arm for Dynabelter Model 11476 add: <ul style="list-style-type: none"> 11544 Pressure Bar Three 95150 Mounting Screws 11794 Back Wheel Assembly 	1" x 30"	11618 90 durometer standard serrated urethane 2" dia. x 1" wide	None
11870	 <ul style="list-style-type: none"> 2" dia. x 2" wide urethane wheel assemblies are only for extra heavy-duty tools 7" workable reach 	2" x 30"	2" dia. x 2" wide rubber assemblies available: 11847: (Included) 70 durometer standard serration 11849: 70 durometer scoop serration 11851: 90 durometer standard serration 11853: 90 durometer scoop serration	Optional 11659 2" x 2-1/2"

Dynangle®

Air-Powered Abrasive Belt Tool

ABRASIVE CAPACITY
ABRASIVE BELTS
 1" wide x 18" long
 (25 mm x 457 mm)

Powerful Direct-Drive Air Motor with Adjustable Speed

Model 14200

- Compact tool is ideal for work in tight spots; handle is multi-positional. Perfect for blending radiuses and adding grain to stainless steel sinks.
- Quick and easy abrasive belt change. Accepts coated abrasive belts and non-woven nylon belts.
- Interchangeable Contact Arms match specific applications on stainless steel (see below). Also ideal for refinishing drilling screws and pump screws.
- Includes 14266 Contact Arm and 11605 Hard/Cork Dynapad® Platen Pad.

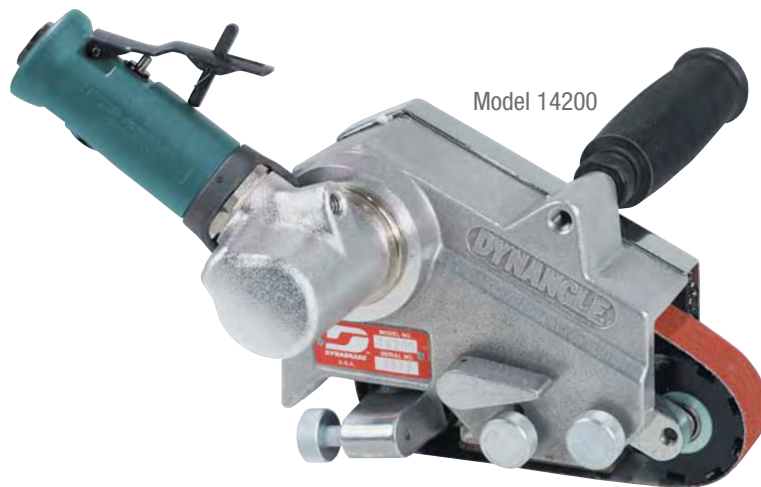

 When working on spot welds, lower platen to avoid gouging of work surface with contact wheel.

Model Number	Motor hp (W)	Motor RPM	Sound Level	Abrasive Belt Size Inch (mm)	Maximum Air Flow SCFM (LPM)	Max. SFPM (SMPM)	Weight Pound (kg)	Length Inch (mm)	Height Inch (mm)
14200	.7 (522)	20,000	92 dB(A)	1 (25) W x 18 (457) L	36 (1,020)	6,540 (1,987)	4.8 (2.2)	11 (279)	5 (127)

Additional Specifications: Air Inlet Thread 1/4" NPT • Hose I.D. Size 3/8" (10 mm) • Air Pressure 90 PSIG (6.2 Bar)
 Tune-Up Kit: No. 96045 (page 192) • Recommended Air Line Accessory: 95676 Coupler/Plug Assembly (page 161)

Dynangle® Contact Arms

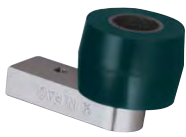
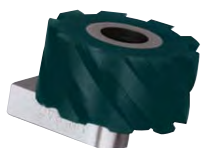
Part Number	Belt Size (W x L)	Contact Wheel Assembly (includes bearing and shaft)	Wheel Material	Surface	Use
14261 	1" x 18"	14251 1" dia. x 1" wide	70 durometer urethane	Smooth	1/2" radiused corner
14263 	1" x 18"	14253 1-1/2" dia. x 1" wide	70 durometer urethane	Smooth	3/4" radiused corner
14266 	1" x 18"	14256 2" dia. x 1" wide	70 durometer rubber	Standard serrated	1" radiused corner

Dynangle® II

Air-Powered Abrasive Belt Tool

ABRASIVE CAPACITY

ABRASIVE BELTS

2" wide x 34" or 45" long
(51 mm x 864 mm, 1143 mm)

Polish, Grind Contours and Flats

- Surface conditions stainless steel and most other metals. Also used on wood, plastic, fiberglass and composites. Blends and finishes solder seams.
- Built-in abrasive belt guard; fast belt change.
- Safety-lock lever-throttle; hanger brackets included for optional overhead suspension.

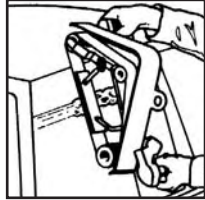

Model 14300 Single Motor

- Uses 2" x 34" belts; belts spans 11-1/2" for "strap polishing" up to 36" diameter pipe.
- 14350 Conversion Kit available to upgrade single motor model to a dual motor model at a later date, if desired.

NOTE: For grinding with a platen pad, dual motor models are recommended.

Model 14303 Heavy-Duty "Dual Motor" with Platen

- Heavy-duty "dual motor" for extra power.
- Uses 2" x 34" belts; belts spans 11-1/2" for "strap polishing" up to 36" diameter pipe.
- Includes 2" wide x 6" long platen which is easily removed for strap polishing.

Model 14306 Heavy-Duty "Dual Motor" with Platen

- Heavy-duty "dual motor" for extra power.
- Uses 2" x 45" belts; belts spans 17" for polishing pipe up to 48" diameter.
- Includes 2" wide x 6" long platen which is easily removed for strap polishing.



14300 Dynangle® II is utilized for "strap polishing" on a cylindrical stainless steel surface.



Model 14303



For optimum use of Dynangle® II, it is critical that proper air flow is maintained.



To maintain belt tension, use "J-Weight" abrasive belts with low-flex or low-stretch backing.

Model Number	Motor hp (W)	Motor RPM	Sound Level	Abrasive Belt Size Inch (mm)	Maximum Air Flow SCFM (LPM)	Max. SFPM (SMPM)	Weight Pound (kg)	Length Inch (mm)	Height Inch (mm)
14300	1.2 (895)	13,000	85 dB(A)	2 (51) W x 34 (864) L	53 (1,501)	8,500 (2,591)	15.1 (16.9)	18-7/8 (479)	8-1/2 (216)
14303	2.4 (1,790)	13,000	85 dB(A)	2 (51) W x 34 (864) L	106 (3,002)	8,500 (2,591)	18.7 (8.2)	18-7/8 (479)	9-9/16 (243)
14306	2.4 (1,790)	13,000	90 dB(A)	2 (51)W x 45 (1,143) L	106 (3,002)	8,500 (2,591)	19.2 (8.7)	22-7/8 (581)	9-1/2 (241)

Additional Specifications: Air Inlet Thread 1/2" NPT • Hose Size 1/2" (13 mm) • Air Pressure 90 PSIG (6.2 Bar)

Tune-Up Kit: No. 96011 (Dual motor models require two Tune-Up Kits) • Recommended Air Line Accessory: 98273 Coupler/Plug Assembly (page 161)



FASTTRACK

“Take-About” Sander

Air-Powered Abrasive Belt Tool

ABRASIVE CAPACITY
ABRASIVE BELTS
 3" wide x 24" long
 (76 mm x 610 mm)

Ideal for Surface Leveling, Graining and Finishing

Model 52900

- Heavy-duty 1.3 hp sander (12,000 RPM) powers 3" x 24" abrasive belts, for aggressive material removal on metal and wood.
- Toggle switch offers simple one-step belt tensioning.
- Pistol-grip handle and top control knob allow enhanced operator control.
- Easily adjustable tracking of abrasive belt.
- Tool works well with non-woven nylon belts.
- Safety-lock throttle lever is included.



Model 52900

Model Number	Motor hp (W)	Motor RPM	Sound Level	Abrasive Belt Size Inch (mm)	Maximum Air Flow SCFM (LPM)	Max. SFPM (SMPM)	Air Inlet Thread	Weight Pound (kg)	Length Inch (mm)	Height Inch (mm)
52900	1.3 (969)	12,000	88 dB(A)	3 (76) W x 24 (610) L	50 (1,416)	1,700 (516)	3/8" NPT	12.5 (5.7)	13-1/4 (337)	7-1/8 (181)

Additional Specifications: Air Pressure 90 PSIG (6.2 Bar) • Hose I.D. Size 1/2" (13 mm) • Recommended Accessory: 98265 Coupler/Plug Assembly (page 161)

Platen Pads

Provide Belt Support on Dynabrade Abrasive Belt Tools

Soft Platen Pads • Top facing • Sponge base • Pressure sensitive adhesive

Part Number	For Use on These Tools	Width	Length	Thickness	Package Quantity
11032	Dynafile®, Dynafile® II	1/4"	7"	1/8"	5
11025	Dynafile®, Dynafile® II, Dynafile® III	1/2"	7"	1/8"	5
11119	Dynafile® II	3/4"	7"	1/8"	5
15323	Dynafile® III	1"	2"	1/8"	5

For work on contoured pieces



1/8" (3 mm)



11025 Platen Pad affixed to 11218 Dynafile® Contact Arm

Hard Platen Pads • Top facing • Cork base • Pressure sensitive adhesive

Part Number	For Use on These Tools	Width	Length	Thickness	Package Quantity
11033	Mini-Dynafile® II	1/4"	7"	1/8"	5
11026	Dynafile®, Dynafile® II, Mini-Dynafile® II, Dynafile® III	1/2"	7"	1/8"	5
11109	Dynafile® II, Dynafile® III	3/4"	7"	1/8"	5
15324	Dynafile® III	1"	2"	1/8"	5

For heavy deburring and polishing



1/8" (3 mm)

Thin Platen Pads • Top facing • Pressure sensitive adhesive

Part Number	For Use on These Tools	Width	Length	Thickness	Package Quantity
11034	Dynafile®, Dynafile® II	1/4"	7"	1/32"	5
11027	Dynafile®, Dynafile® II, Mini-Dynafile® II	1/2"	7"	1/32"	5
11129	Dynafile® II	3/4"	7"	1/32"	5

For use with Contact Arms with small diameter Contact Wheels (such as 11212)



1/32" (.8 mm)

